

ARGON 18



VALID FOR DARK MATTER 373A-B-C / 2025-II-01

**DARK
MATTER**

ARGON 18



VALID FOR DARK MATTER 373A-B-C / 2025-II-01

DARK
MATTER

ARGON 18



VALID FOR DARK MATTER 373A-B-C / 2025-II-01

DARK
MATTER

TABLE OF CONTENTS

1. Tools Needed & Spare Parts Kit	5
2. Troubleshooting / Tips & Specifications	6
3. Frameset Inspection	7
4. Frameset Skus & Descriptions	8-9
5. Seat Post Installation	10
6. Seat Post Min. & Max. Insertion	11
7. Seat Post Assembly	12
8. Rear Derailleur Hanger Assembly	13
9. Front Derailleur Hanger Assembly	14
10. 3D Headset Installation	15
11. Cable and Housing Routing – Mechanical 1X Shifting	16-17
12. Cable and Housing Routing – Mechanical Shifting	18-19
13. Cable and Housing Routing – Electronic Wireless	20-21
14. Cable and Housing Routing – Electronic Wire	22-23
15. Cable and Housing Routing – Dropper seatpost	24
16. Downtube Cable Clamp Installation	25
17. Bottom Bracket Cover Installation	26
18. Downtube Protector Installation	27
19. Fork Installation	28
20. Toolkit Installation	29-32
21. Bottle Cage Position	33
22. Cable and Housing Routing – Dynamo routing	34
23. Rear Rack And Fender Installation	35-36
24. Front Rack And Fender Installation	37



MY DARK MATTER

Date of Purchase: _____

Retailer: _____

Size: _____

Serial Number: _____

To maintain the validity of the warranty, the bicycle must be fully assembled by an [authorized Argon 18 dealer](#). High-end components, particularly carbon parts, require extra care during assembly.

These components must be installed using a torque wrench to ensure each bolt is at the specified torque setting to prevent damage.

1. TOOLS NEEDED & SPARE PARTS KIT

1. Hydraulic Hose Cutter



2. Allen Key Set

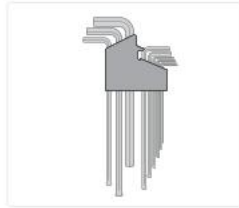

3. Flush cut plier



4. Carbon Paste & Grease



5. Utility Picks



6. Clean Rag



7. Derailleur Hanger Alignment Gauge

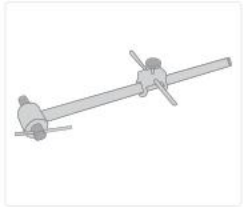

8. Cables and Housing Cutter



9. Thread Locker Medium strength



10. Isopropyl Alcohol



11. Torque Wrench



12. Headset Press



13. 8mm Wrench



14. Bleed Kit



15. Torx Key Set

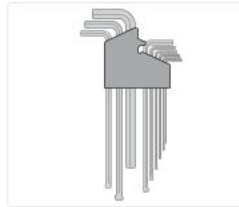

16. Mineral Oil



SPARE PARTS KIT



IMPORTANT:

Spare Parts Kit: Essential parts to always have on hand IN CASE OF EMERGENCY... THIS MIGHT SAVE YOUR RIDE!

1. Seat Post Clamp



80801

2. Spare Rear Derailleur Hanger (if used)



UDH
201345



UDH Direct Mount
201506

2. TROUBLESHOOTING / TIPS & SPECIFICATIONS

Brakes

- Front brake - 160/180mm disc rotors
- Rear brake - 140/160mm disc rotors

Rear mount thickness: 20mm.

Thru-axles

- Front axle: Ø12mm x 119mm length, Threads M12 x P1.5 x 12mm length.
- Rear axle: Ø12mm x 167.5mm length, Threads M12 x P1.0 x 14.5mm length.
- Rear derailleur hanger UDH standard.

Tire Clearance

Maximum clearance: 700c x 57mm (29"x2.2"), in 1x configuration.

Tire clearance is affected by crank and front derailleur choice.

Frame size	SRAM		SHIMANO		
	1x	2x wide	1x	2x GRX Di2	2x GRX Mech.
XXS	57mm	55mm	57mm	57mm	55mm
XS				55mm	
S				53mm	
M				53mm	
L				52mm	
XL				50mm	

Headset

A18 3D IST2

- Bottom Bearing: MR127 - 1 1/2", 36° x 45° Stainless Steel
- Top Bearing: MR127 - 1 1/2", 36° x 45° Stainless Steel

*Some systems may require a 1 1/2", 45° x 45° top bearing

For more information, please refer to: [Argon 18 - Internal routing compatibility](#)

Front Derailleur

The Dark Matter is compatible with a front derailleur, with the use of the removable front derailleur hanger (SKU: 201334).

Suspension Fork Compatible

The geometry of the new Dark Matter is corrected to fit gravel suspension forks of 40 or 50mm travel without affecting its handling characteristics. The rigid carbon-fiber composite fork has a length of 425mm with a rake of 54mm (sizes XXS, XS) and 48mm (sizes S, M, L, XL).

- Compatible forks: Fox 32 TC, Rock Shox Rudy, Cane Creek Invert CS.
- Non-compatible fork: KS GTC.

Chainring

The Dark Matter is only compatible with gravel groupsets.

Not compatible with road-specific groupsets (ex.: Dura-Ace, Ultegra, 105, etc.).

- Single chainring (1x): max. 48T in Shimano GRX, max. 46T in SRAM Wide
- Double chainring (2x): max. 48/31T, min. 46/30T (Shimano), 43/30T (SRAM)

Power Meter

The Dark Matter is designed to work with most of the power meters available on the market.

- For **hub/wheel-based power meters**:

The system must be compatible with a 12mm x 142mm O.L.D. rear thru-axle.

- For **crank/chainring-spider-based power meters**:

The frame has enough clearance to fit most models of SRAM, Stages, Quarq, Rotor, SRM, 4iiii, FSA PowerBox (Power2Max NG Eco), etc.

Non-Drive-Side crank arm power meters only compatible with SRAM Wide.

Accessories

The Dark Matter is designed to take fenders, with the use of the removable brackets. (with fenders, tire clearance is reduced to 700x50mm)

The Dark Matter can also support a rear rack up to 27kg and a front rack up to 18kg. The cable-routing is dropper-post compatible in all configurations.

Bottom Bracket

Threaded T47, 85.5mm width

Seat Post

Ø 27.2mm

Seat Post Collar

Ø 31.8mm

Please contact customer service at info@argon18.com for any further inquiries.

3. FRAMESET INSPECTION

Before assembling your new Dark Matter, please complete the following:

1. Verify you have all necessary frameset parts checklist (see p.8-9).
2. Inspect the frame for cosmetic defects (scratches, bumps, cracks, paint defects, etc.).
3. For reference, record serial number on p.4.
4. For optimal shifting performance, use a derailleur alignment gauge to make sure that the derailleur hanger is straight.



Some of the following parts are already assembled on the frame. When assembling the bike, you will need to adjust these parts according to their torque specifications and fastener conditions when necessary.

No.	A18 SKU#	Function	Description	Screw Type	Torque	Detail	Qty
1	80801*	Seatpost Collar Screw	M5 x 22mm Screw	Socket Head	4 Nm	Grease	1
2	SP.KR.365A*	Front Saddle Clamp Screw	M8 x 35mm Screw	-	9.5 Nm	Grease	1
3	SP.KR.365A*	Rear Saddle Clamp Screw	M6 x 30mm Screw	Socket Head	9.5 Nm	Grease	1
4	81052	Front Thru Axle	M12 x 1.5 x 119mm Axle	Thru Axle	10 Nm	Grease	1
5	201329	Rear Thru Axle	M12 x 1.0 x 167.5mm Axle	Thru Axle	10 Nm	Grease	1
6	201345 or 201506	Rear Derailleur Hanger Screw (UDH)	Left-Hand UDH threads	-	25 Nm	Dry	1
7	201334*	Front Derailleur Hanger Screw	M5 x 14mm Screw	Flat Head	3 Nm	Grease	2
8	200816*	Cable Clamp Screw	M5 x 18mm Screw	Flat Head	Hand Tight	Threadlocker	1
9	201337*	Down Tube Protector Screw	M5 x 10mm Screw	Button Head	Hand Tight	Grease	3
10	200821*	Door Pad Screw	M4 x 5mm Screw	Flanged Button Head	Hand Tight	Threadlocker	4
11	200820*	Door Lever Screw	M5 x 14mm Screw	Flat Head	3 Nm	Threadlocker	1
12	200820*	Door Locator Screw	M3 x 5mm Screw	Flat Head	Hand Tight	Threadlocker	1
13	200820*	Door Threaded Insert Screw	M3 x 10mm Screw	Flat Head	Hand Tight	Threadlocker	2
14	81195	Water Bottle Screw	M5 x 14mm Screw	Button Head	3 Nm	Grease	4
15	201343*	Rear Fender Bracket Screw	M5 x 10mm Screw	Button Head	Hand Tight	Grease	2
16	-	Rear Rack and Fender Screw	M5 (not provided)	-	3-5 Nm	Grease	-
17	201344*	Front Fender Bracket Screw	M5 x 14mm Screw	Button Head	Hand Tight	Grease	2
18	-	Front Fender and Dynamo Screw	M5 (not provided)	-	3-5 Nm	Grease	-

* Included with



Torque Value
Allen key size



Apply **carbon paste** on the indicated surfaces.



Apply **threadlocker** on the indicated surfaces.



Apply **grease** on the indicated surfaces.



IMPORTANT:

Indicates special precautions and important steps that must be taken to avoid damage and/or injury.

Torque value:
Under-torquing may cause parts to slip and cause injury.
Over-torquing may cause screw to break and/or part to slip and cause injury.

4.1 FRAMESET SKUS AND DESCRIPTIONS

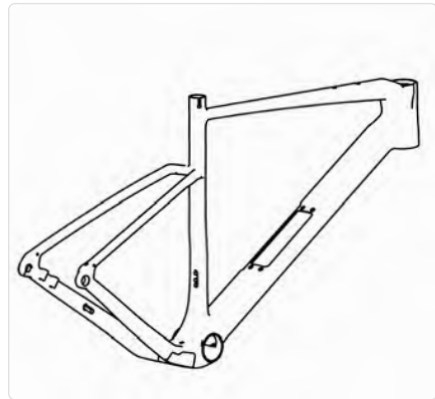

Dark Matter Frame
*Not available as a separate SKU

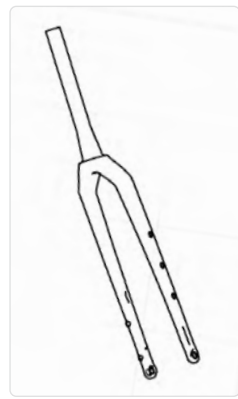

FK.DM.XXS-XS.373A / B / C
FK.DM.S-XL.373A / B / C

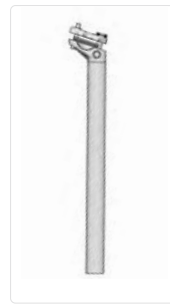

SP.KR.365A



201337

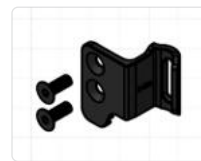

201334

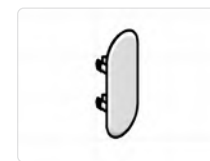

201335



201332 (CS Guard)
201333 (CS bumper)



80804



201347 (373A)
201349 (373B)
201351 (373C)



201348 (373A)
201350 (373B)
201352 (373C)



100146



80805



201336



200832



200829



200828



200816



80985



81054



80264



80801



201170



201171

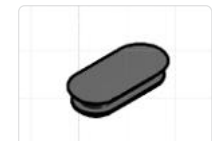

201338



201339



81052



201380



80811

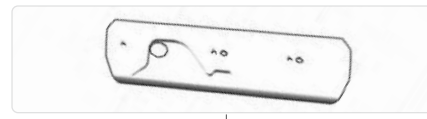

201340 (373A)
201341 (373B)
201342 (373C)



201345



201506

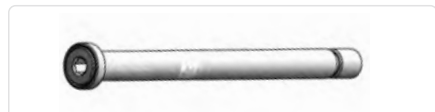

201329

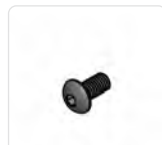

81195



200725

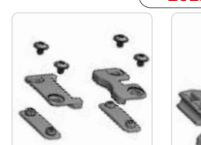

200821



200820

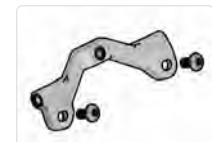

201343



201344

Except for the frame itself, which is not sold separately as a spare part, all parts can be ordered by referring to their respective SKU number.

4.2 FRAMESET SKUS AND DESCRIPTIONS

NO.	NAME	A18 SKU#	QTY
1	Dark Matter Frame	-	1
2	Dark Matter Fork 48 mm (S-M-L-XL) -OR- Dark Matter Fork 54 mm (XXS-XS)	FK.DM.S-XL.373A / 373B / 373C FK.DM.XXS-XS.373A / 373B / 373C	1
3	Seatpost Krypton / Dark Matter 365A	SP.KR.365A	1
4	Chain Suck Guard - Dark Matter	201332	1
5	CHAINSTAY BUMPER - Dark Matter	201333	1
6	FD HANGER REMOVABLE (Incl. screws) - Dark Matter	201334	1 Set
7	FD PLUG - Dark Matter	201335	1
8	CHAINSTAY FRAME PROTECTOR - Dark Matter	201336	1
9	DOWN TUBE FRAME PROTECTOR - Dark Matter	201337	1 Set
10	Long Grommet Mechanical	80985	2
11	Long Plug Grommet	80804	5
12	Long Grommet Di2	80805	3
13	OBLONG PLUG	201338	1
14	OBLONG GROMMET	201339	2
15	Water bottle cage screw	81195	4
16	M5 Plastic Plug	80264	15
17	M4 Plastic Plug	201380	2
18	Dark Matter Toolkit Door	201340 (373A) / 201341 (373B) / 201342 (373C)	1
19	Toolkit Backbone Kit	200820	1 Set
20	Toolkit Door-Pads Kit	200821	1 Set
21	Cable Clamp Top & Bottom (With Screw)	200816	1 Set
22	BB Cover (SUM / E117 / Dark Matter)	100146	1
23	HEADSET CAP 0mm	201347 (373A) / 201349 (373B) / 201351 (373C)	1
24	HEADSET CAP 25mm	201348 (373A) / 201350 (373B) / 201352 (373C)	1
25	SRS Headset adaptor (IST2)	201170	1
26	ACR Headset adaptor (IST2)	201171	1
27	HEADSET COLUMN 25mm	200828	1
28	IST2 - HEADSET SLEEVE	200829	1
29	REAR FENDER BRACKET - Dark Matter	201343	1 Set
30	FRONT FENDER BRACKET - Dark Matter	201344	1 Set
31	GWM Thru Axle Rear Custom 167.5 x12 SB-01 HOLLOW Switch Compatible	201329	1
32	GW front thru axle 12mm for DO spacing 100mm	81052	1
33	Removable lever for GW thru axle 12mm	81054	1
34	Foam Liner For Hydraulic Hose	80811	3
35	Di2 Battery Holder (BT-DN300) For 27.2mm SP	200725	1 Set
36	Seatpost Collar	80801	1
37	Toolpouch	200832	1
38	*** OPTIONAL *** SRAM Universal Derailleur Hanger (UDH)	201345	1
39	*** OPTIONAL *** Direct mount hanger (UDH)	201506	1

5. SEATPOST INSTALLATION

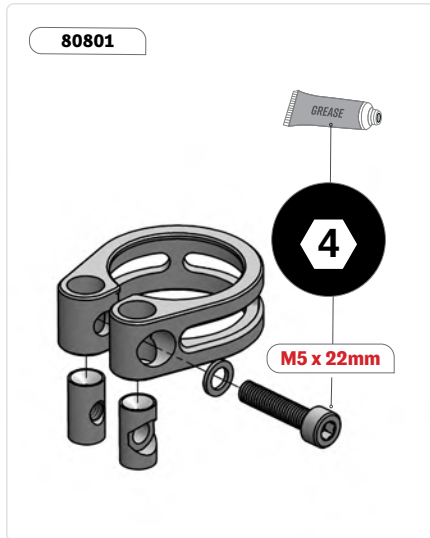

1. Apply grease on the threads of the M5x22mm socket head screw.
2. Assemble the seat post collar (SKU: 80801) as shown.
3. Adjust the seatpost to the desired height. Make sure to follow the seatpost min and max insertion limits. (p. 11)
4. Tighten the M5x22mm socket head screw on the seatpost clamp to 4Nm.



IMPORTANT:

Refer to p.11 for seatpost **MIN** and **MAX** insertion limits.

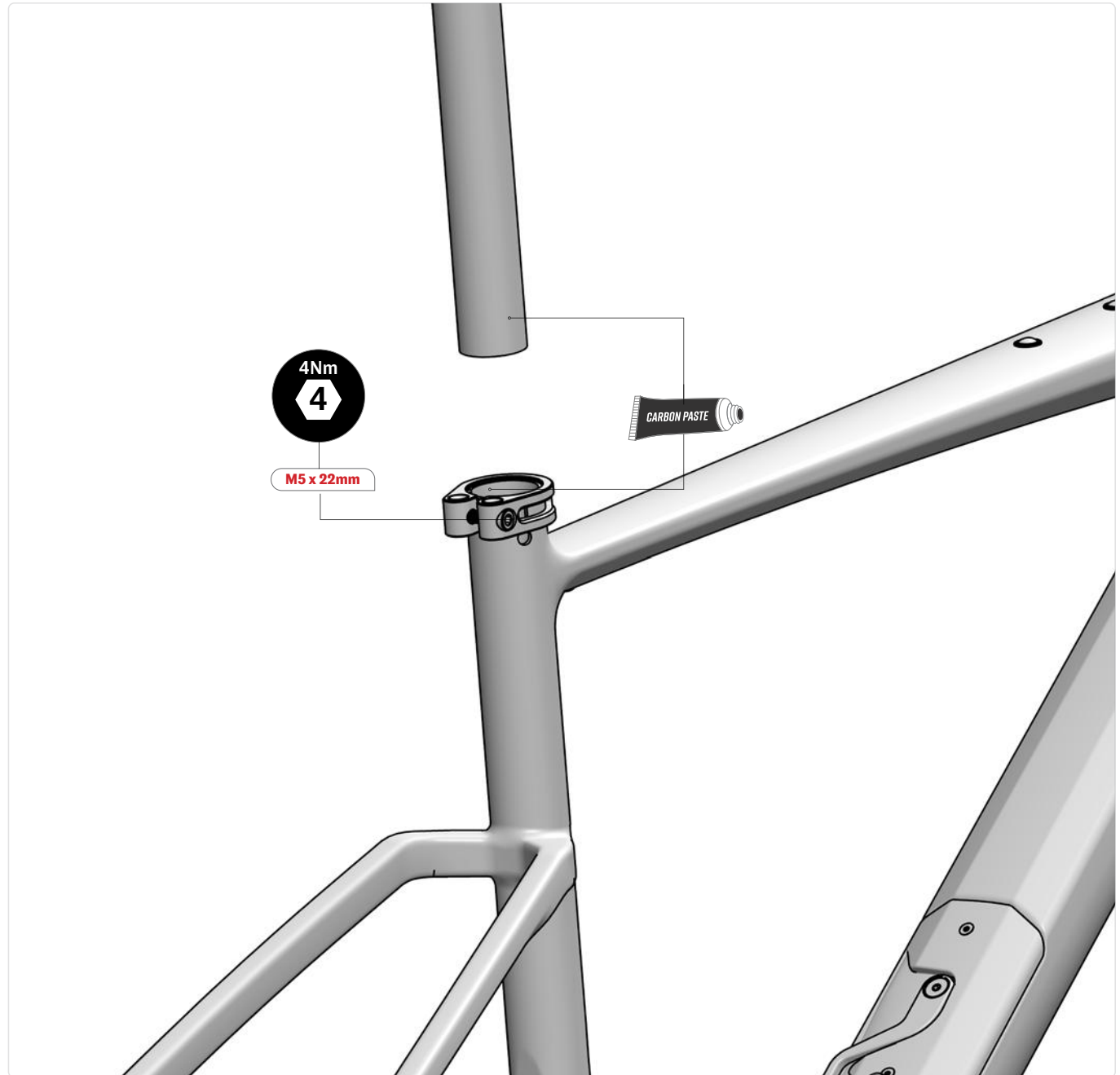

6. SEATPOST MIN. & MAX. INSERTION



Refer to the adjacent table for details on saddle height and seatpost insertion limits:

i. The correct frame size must be determined according to the saddle height limits.

- A. Maximum Saddle Height.
- B. Minimum Saddle Height.

ii. Depending on the size of the frame and the desired saddle height, the seatpost might need to be cut.

If the desired saddle height is lower than value "C", calculate the required cutting length "G" as follow:

$$G = C - \text{"Desired saddle height"} + 10\text{mm (to allow adjustment)}$$

Example: For a desired saddle height of 615mm on a XX-Small frame, the required minimum seatpost cut length (G) is:

$$G = 645 - 615 + 10 = 40 \text{ mm}$$

Important: The saddle height can't be lower than value "B".

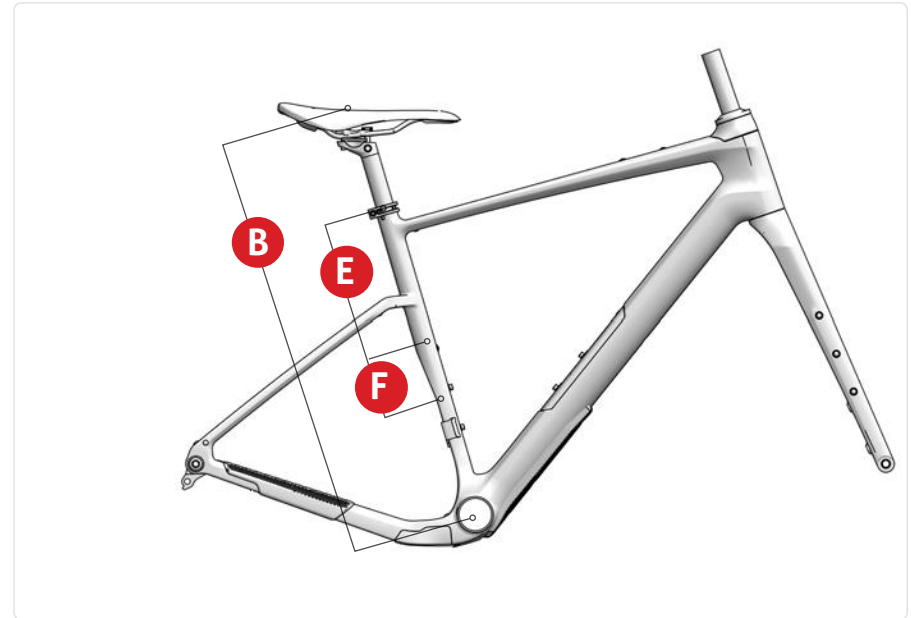

SADDLE HEIGHT LIMITS (MM)

SIZE	Max Saddle Height	Min Saddle Height	Min Saddle Height (Without cut)	Min Seatpost Insert	Max Seattube Insert	Max Seatpost Cut
	A	B	C	D	E	F
XX-SMALL	740	540	645	80	175	105
X-SMALL	755	555	645	80	190	90
SMALL	780	580	670	80	190	90
MEDIUM	815	615	670	80	225	55
LARGE	860	660	670	80	270	10
X-LARGE	905	705	705	80	315	0

Based on saddle with 50mm between center of rail to top.



Minimum Seatpost Insertion: 80mm
Maximum Seatpost Cut: 115 mm

7. SEAT POST ASSEMBLY

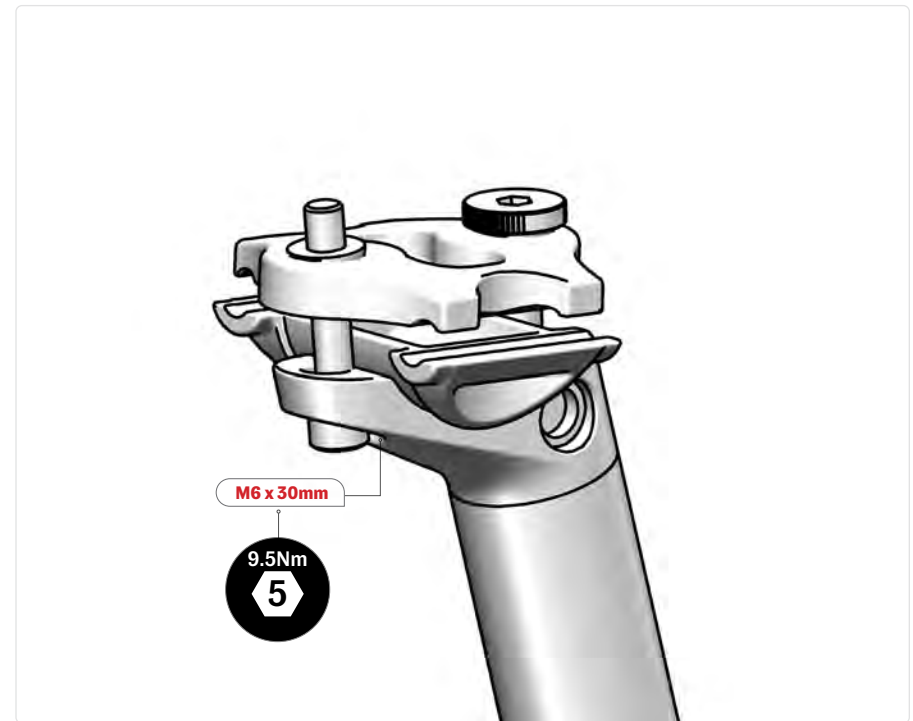
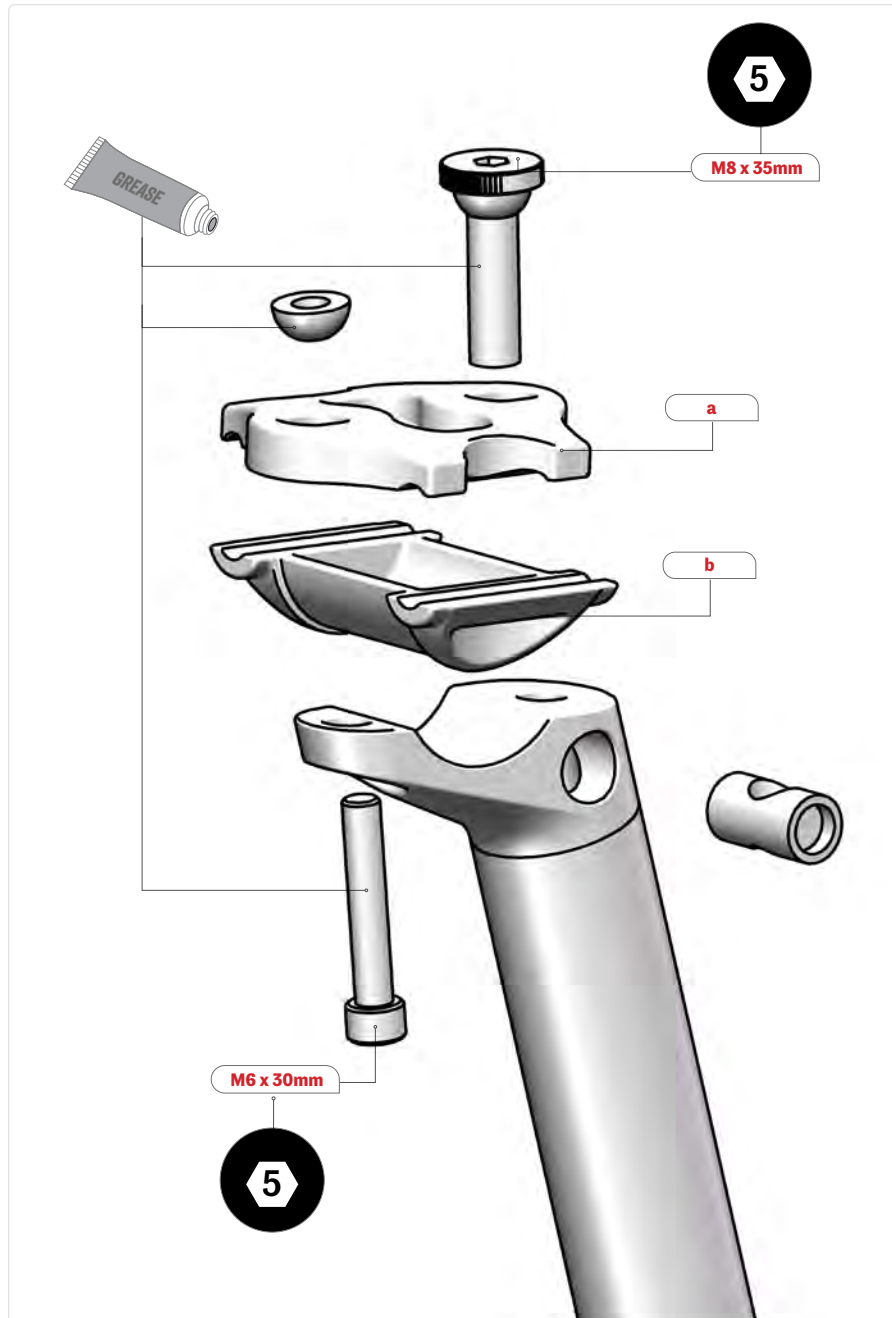

The seat post is supplied fully assembled.

1. Unscrew both screws slightly until the top clamp (a) and the cradle (b) are separated enough to insert the saddle rail. Do not unscrew the bolts completely.
2. Apply grease on the threads of each bolt, on the spherical washer and on the barrel.
3. Tighten both bolts in order to adjust the angle of the saddle and clamp the rail.
4. Tighten both screws to 9.5Nm.

8. REAR DERAILLEUR HANGER ASSEMBLY

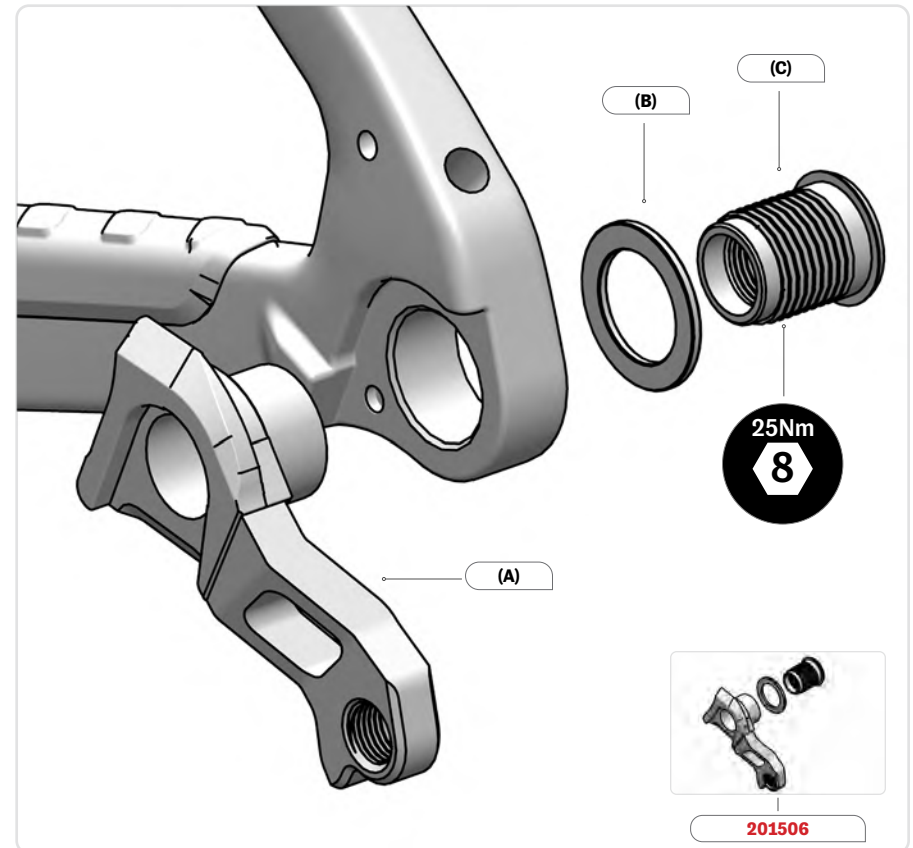
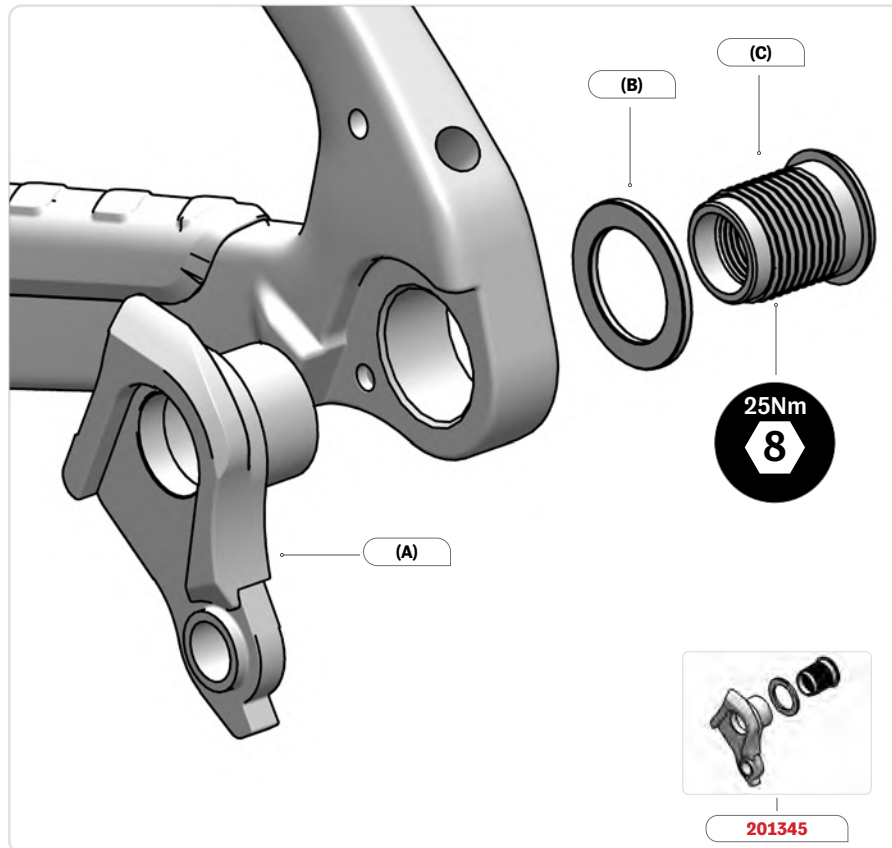

Assembling with a Regular hanger (SKU: 201345) or Direct mount version (SKU: 201506):

1. Install the UDH hanger (A) into the frame dropout. **Do not apply grease to the UDH hanger or bolt.**
2. Rotate the UDH hanger forward until it is completely seated in the hanger pocket and contacts the rotational stop tab.
3. Install the UDH bolt (C) through the washer (B) and into the UDH hanger threads.
4. Tighten the bolt to 25Nm of torque. **The UDH hanger bolt is left-hand threaded.**
5. Confirm the hanger has not moved after applying torque.
6. **Apply grease only to the thru axle threads.**

The Dark Matter is UDH compatible (SRAM Universal Derailleur Hanger standard)

9. FRONT DERAILLEUR HANGER ASSEMBLY

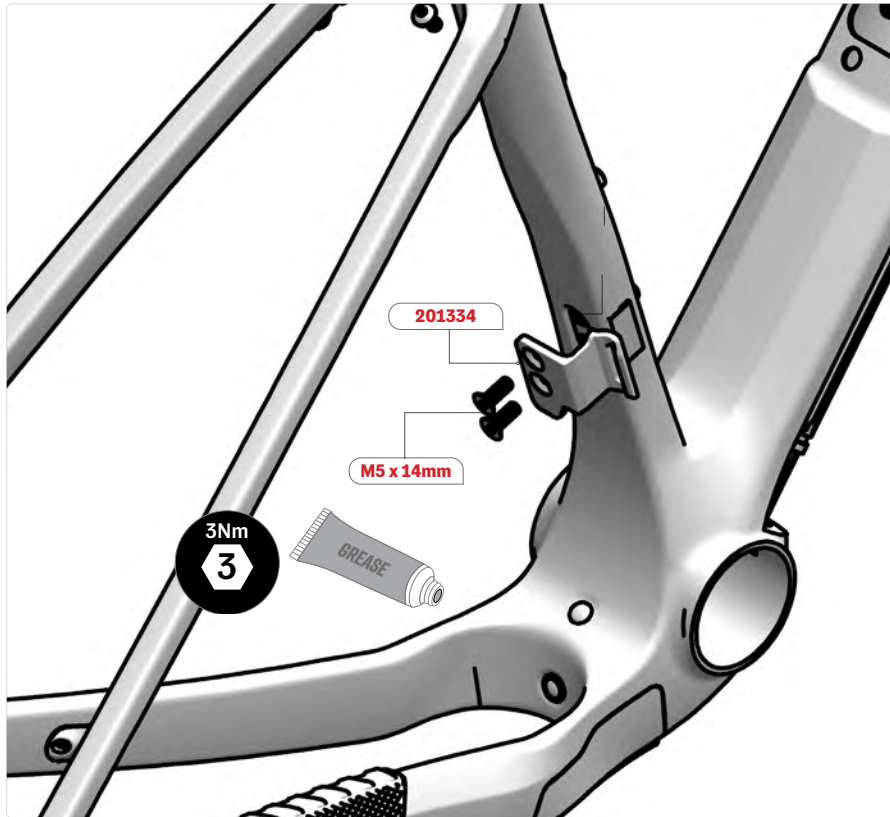

Using a Front Derailleur:

1. Apply grease on the threads of both M5 x 14mm bolts (included in SKU: 201334).
2. Assemble the front derailleur hanger (SKU: 201334) on the frame with the two screws.
3. Tighten both screws to 3Nm.

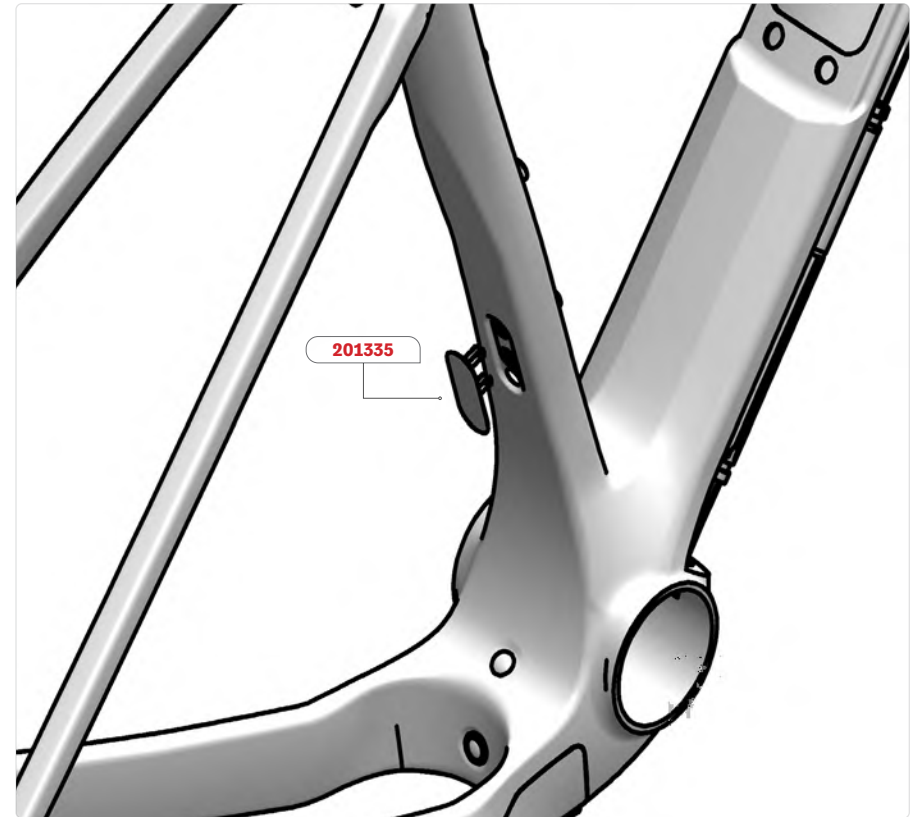

Using a Single Chainring Set-Up:

1. Install the Dark Matter FD plug (SKU: 201335) to cover the hole.

10. 3D HEADSET INSTALLATION

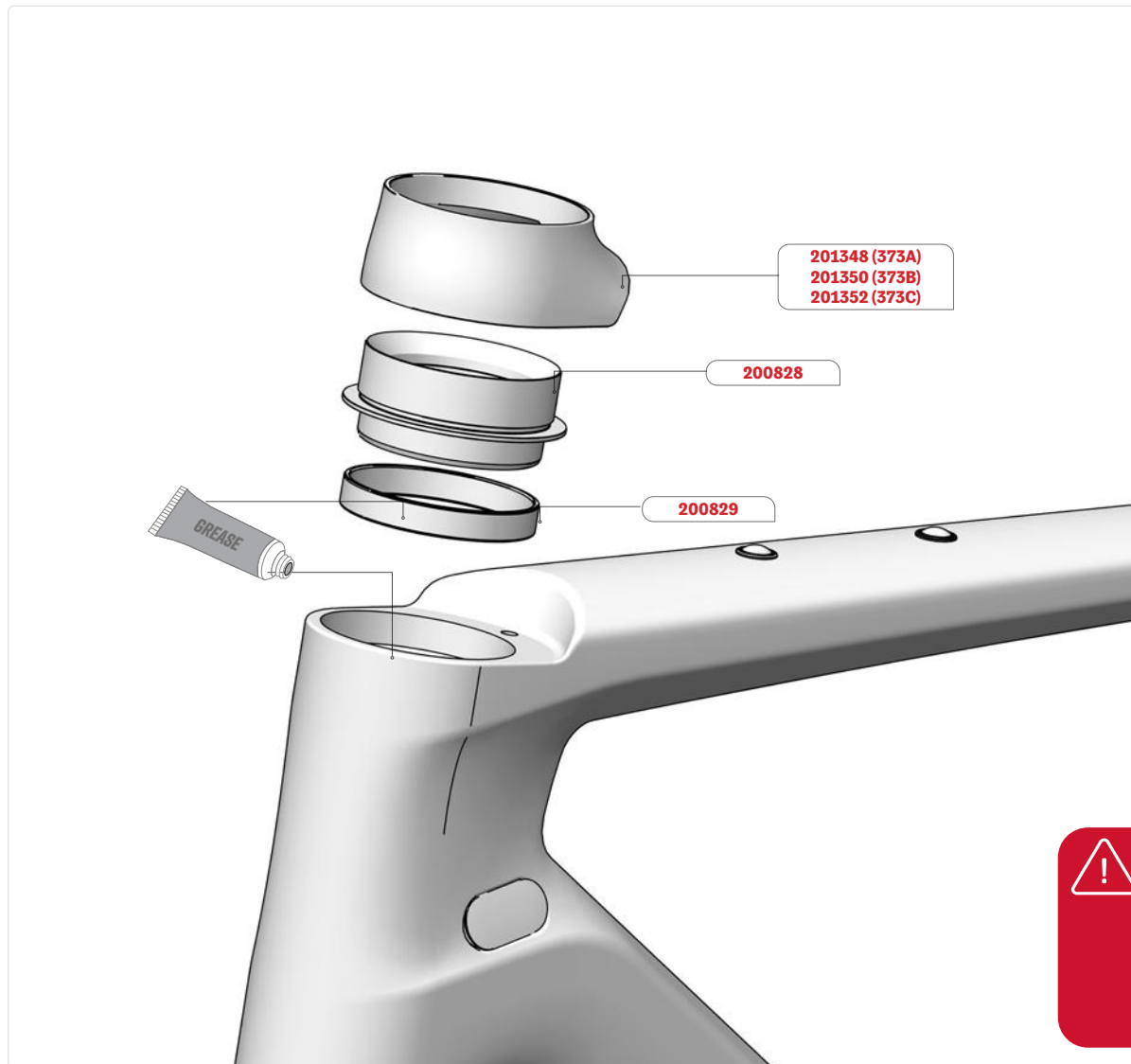

If the 25mm 3D headset is desired, follow the steps below. If no 3D headset is desired, no action is required.

- 1.** Install the 3D headset plastic sleeve (SKU: 200829) into the top of the head tube. (Apply grease on the sleeve)
- 2.** Insert the 25mm headset column (SKU: 200828). (Apply grease on the column)
- 3.** Secure the assembly using a headset press.
- 4.** Push the 25mm Cap on the column while aligning the pin in the frame hole.

AS WITH ALMOST ALL ARGON 18 BIKES, THE DARK MATTER PROVIDES YOU WITH THE BENEFIT OF THE 3D SYSTEM. THIS SYSTEM ALLOWS FOR 2 POSITIONS: 0MM AND 25MM.



IMPORTANT:

No more than 30mm of spacers can be placed between the stem and the top cap of the Headset.

It is critical to assemble the headset expander plug at the same height as the stem's steerer clamp.

11.1 CABLE AND HOUSING ROUTING - MECHANICAL IX SHIFTING



BRAKE HOUSING
DERAILLEUR CABLE/HOUSING

1. All housing will be under the BB once installed.
2. All housing can be covered by a foam liner over the cable clamp (SKU: 80811).
3. Refer to the [Internal Routing Guide](#) on the website for the cable orientation around the steer tube, this depends on the choice of cockpit.

11.2 CABLE AND HOUSING ROUTING - MECHANICAL IX SHIFTING

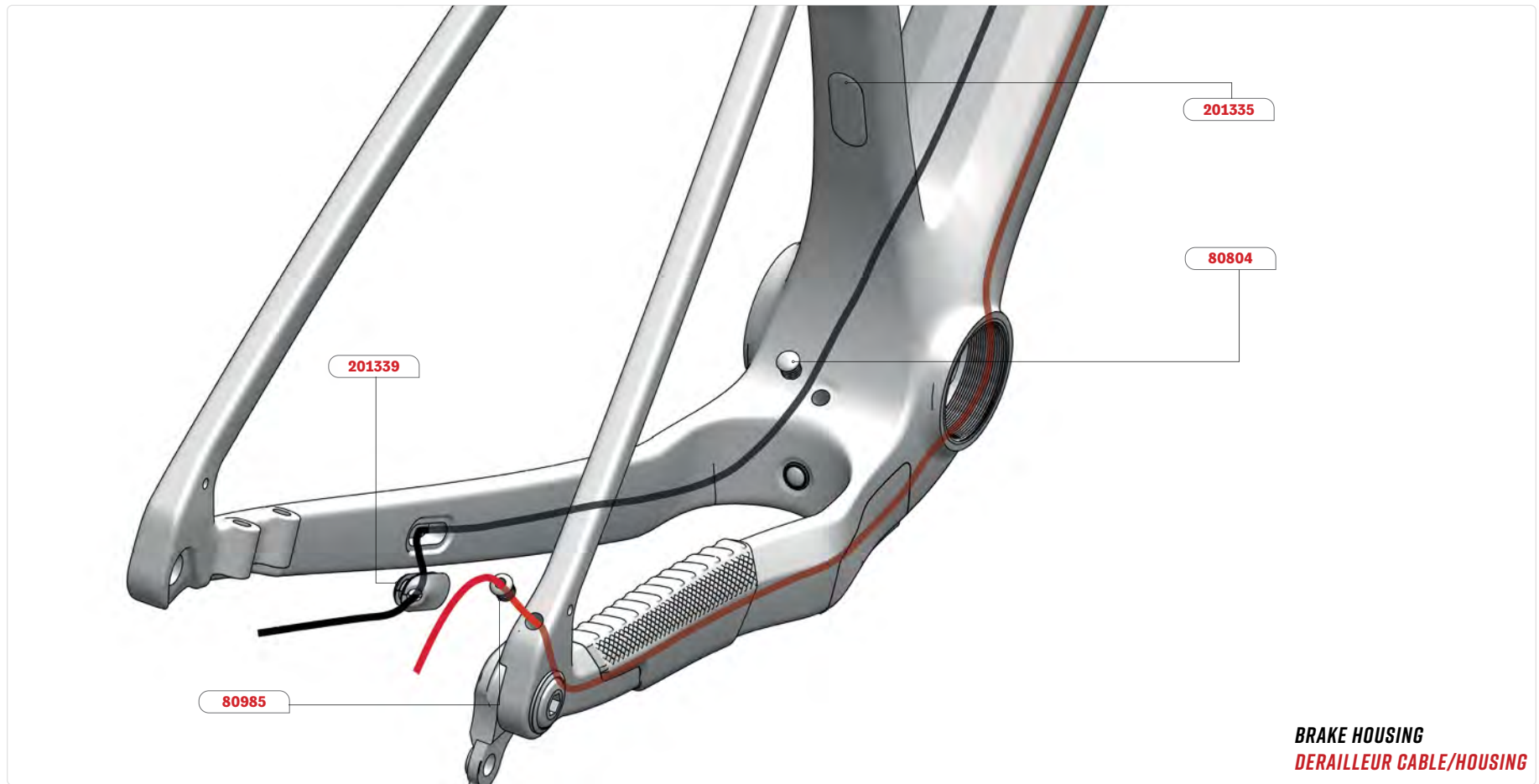

Rear Derailleur:

1. Insert housing from rear hole on the seat stay.
2. Guide the housing under the bottom bracket.
3. Exit the housing through the headtube.
4. Insert the mechanical grommet (SKU: 80985) into the seat stay hole.

Rear Brake:

1. Insert housing from rear hole on the chainstay.
2. Guide the housing under the bottom bracket.
3. Exit the housing through the headtube.
4. Insert the rear brake oblong cable guide (SKU: 201339) into the chainstay hole.

Front Derailleur:

1. Install the Dark Matter FD plug (SKU: 201335) over the two FD hanger rivets. Refer to page 14.
2. Install the pluggrommet (SKU: 80804) in the FD housing exit hole near the Bottom Bracket.

12.1 CABLE AND HOUSING ROUTING - MECHANICAL SHIFTING



BRAKE HOUSING
DERAILLEUR CABLE/HOUSING

1. All housing will be under the BB once installed.
2. All housing can be covered by a foam liner over the cable clamp (SKU: 80811).
3. Refer to the [Internal Routing Guide](#) on the website for the cable orientation around the steer tube, this depends on the choice of cockpit.

12.2 CABLE AND HOUSING ROUTING - MECHANICAL SHIFTING

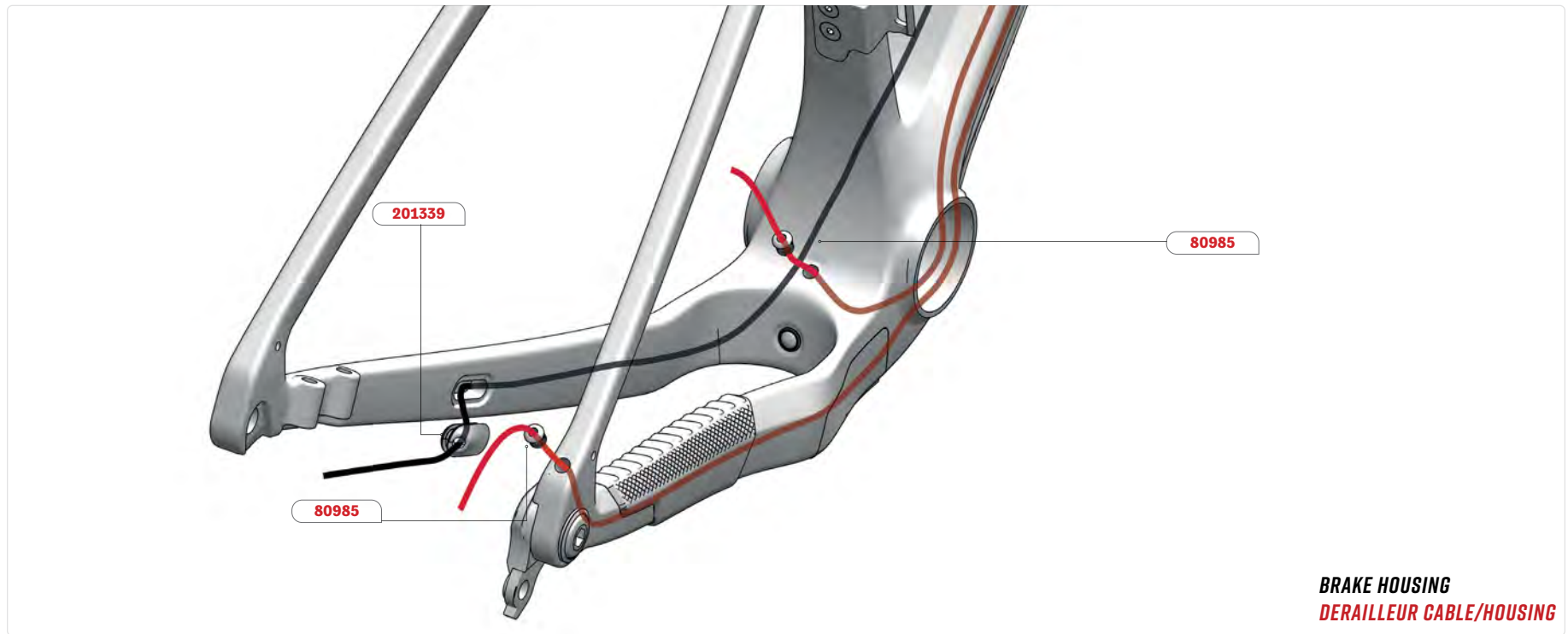

Rear Derailleur:

1. Insert housing from rear hole on the seat stay.
2. Guide the housing under the bottom bracket.
3. Exit the housing through the headtube.
4. Insert the mechanical grommet (SKU: 80985) into the seat stay hole.

Rear Brake:

1. Insert housing from rear hole on the chainstay.
2. Guide the housing under the bottom bracket.
3. Exit the housing through the headtube.
4. Insert the rear brake oblong cable guide (SKU: 201339) into the chainstay hole.

Front Derailleur with full housing:

1. Housing length will depend on the chainring.
2. Insert front derailleur housing from the headtube.
3. Once the housing exits from the BB hole, guide the housing in the hole behind the BB.
4. Install the mechanical grommet (SKU: 80985).
5. Install the housing ferrule.

13.1 CABLE AND HOUSING ROUTING - ELECTRONIC WIRELESS ROUTING



BRAKE HOUSING

- 1.** The rear brake housing will be under the BB once installed.
- 2.** The rear brake housing can be covered by a foam liner over the cable clamp (SKU: 80811).
- 3.** Refer to the [Internal Routing Guide](#) on the website for the cable orientation around the steer tube, this depends on the choice of cockpit.

13.2 CABLE AND HOUSING ROUTING - ELECTRONIC WIRELESS ROUTING

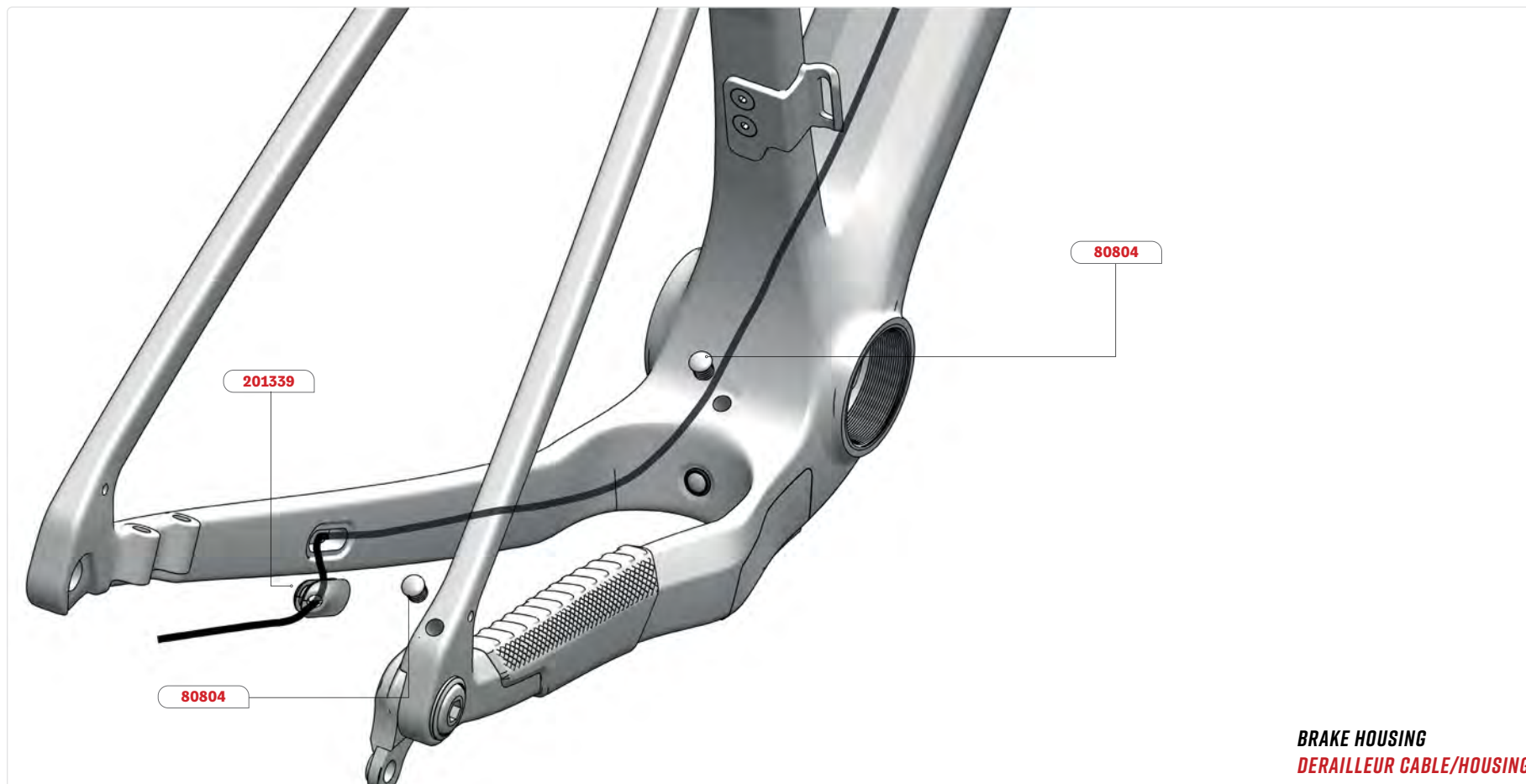

Rear Derailleur:

1. Install the pluggrommet (SKU: 80804) in the seat stay hole.

Rear Brake:

1. Insert housing from rear hole on the chainstay.
2. Guide the housing under the bottom bracket.
3. Exit the housing through the headtube.
4. Insert the rear brake oblong cable guide (SKU: 201339) into the chainstay hole.

Front Derailleur:

1. Install the pluggrommet (SKU: 80804) in the FD housing exit hole.

14.1 CABLE AND HOUSING ROUTING - ELECTRONIC WIRE ROUTING



1. The rear brake housing will be under the BB once installed.
2. The rear brake housing can be covered by a foam liner over the cable clamp (SKU: 80811).
3. Refer to the [Internal Routing Guide](#) on the website for the cable orientation around the steer tube, this depends on the choice of cockpit.

14.2 CABLE AND HOUSING ROUTING - ELECTRONIC WIRE ROUTING

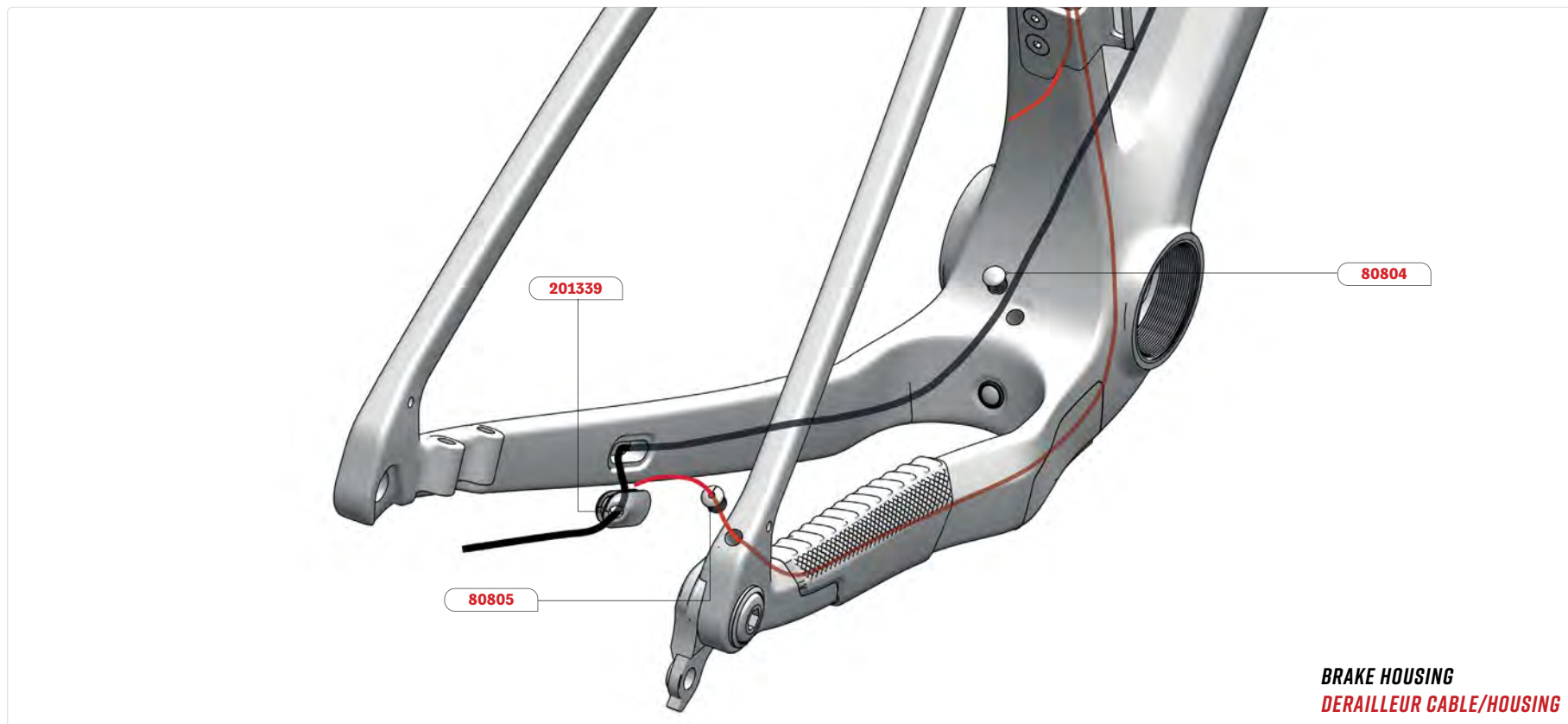

Rear Derailleur:

1. Insert the Di2 rear derailleur cable from rear hole on the seat stay until it exits from the BB hole or the seattube depending on the Di2 generation.
2. Plug the cable into the junction box or into the battery.
3. Insert the Di2 grommet (SKU: 80805) into the seat stay hole.

Rear Brake:

1. Insert housing from rear hole on the chainstay.
2. Guide the housing over the bottom bracket.
3. Exit the housing through the headtube.
4. Insert the rear brake oblong cable guide (SKU: 201339) into the chainstay hole.

Front Derailleur:

1. Insert Di2 front derailleur cable from hole behind seattube, **under the FD Hanger**, until it exits from the BB hole or the seattube depending on the Di2 generation.
2. Plug the cable into the junction box or into the battery.
3. Install the plug grommet (SKU: 80804) in the FD housing exit hole.

15. CABLE AND HOUSING ROUTING - DROPPER SEATPOST

THE DARK MATTER IS COMPATIBLE WITH A DROPPER POST IN MECHANICAL 1X OR AXS BUILD.



IMPORTANT:

Only 4 cables can pass thru the headset per headset manufacturer recommendation.



201339

With an AXS groupset or mechanical 1X groupset (internal routing):

1. The dropper post housing will be above the BB once installed.
2. The dropper post housing can be covered by a foam liner over the cable clamp (SKU: 80811).
3. Insert the housing into the headtube and through the seat tube.
4. Follow dropper seatpost manufacturer installation procedure.

Acheminement externe du câble au niveau du tube de direction :

1. Une fois installé, la gaine de la tige de selle télescopique se trouvera au-dessus du boîtier de pédalier.
2. La gaine de la tige de selle télescopique peut être recouvert d'une doublure en mousse placée sur le serre-câble (réf.: 80811).
3. Insérez la gaine dans l'ouverture située du côté opposé à la transmission du tube de direction et faites-le passer à travers le tube de selle à l'aide de l'œillet oblong (réf.: 201339).
4. Suivez la procédure d'installation du fabricant de la tige de selle télescopique.

16. DOWNTUBE CABLE CLAMP INSTALLATION

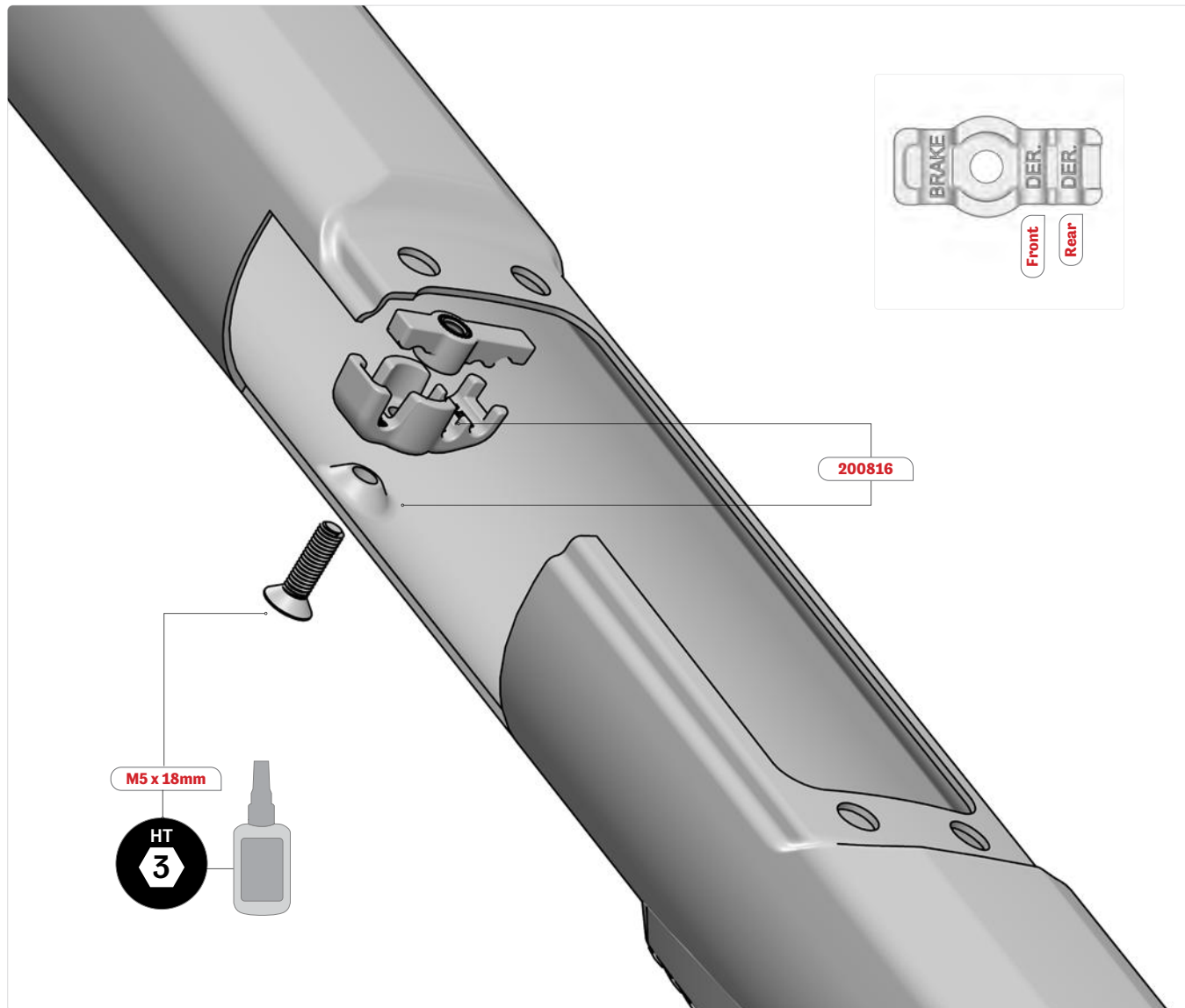

1. Apply a drop of blue threadlocker (no. 242) to the M5 x 18mm screw threads.
2. Install the bottom part of the cable clamp (SKU: 200816). The brake side goes on the non-drive side of the bike.
3. Place all housing in the corresponding position in the cable clamp.
4. Install the top part of the cable clamp.
5. Hand-tighten the M5x12mm screw, making sure that the housing isn't crushed.

17. BOTTOM BRACKET COVER INSTALLATION



1. After installing all cables and housing, install the bottom bracket cover (SKU: 100146).

18. DOWNTUBE PROTECTOR INSTALLATION

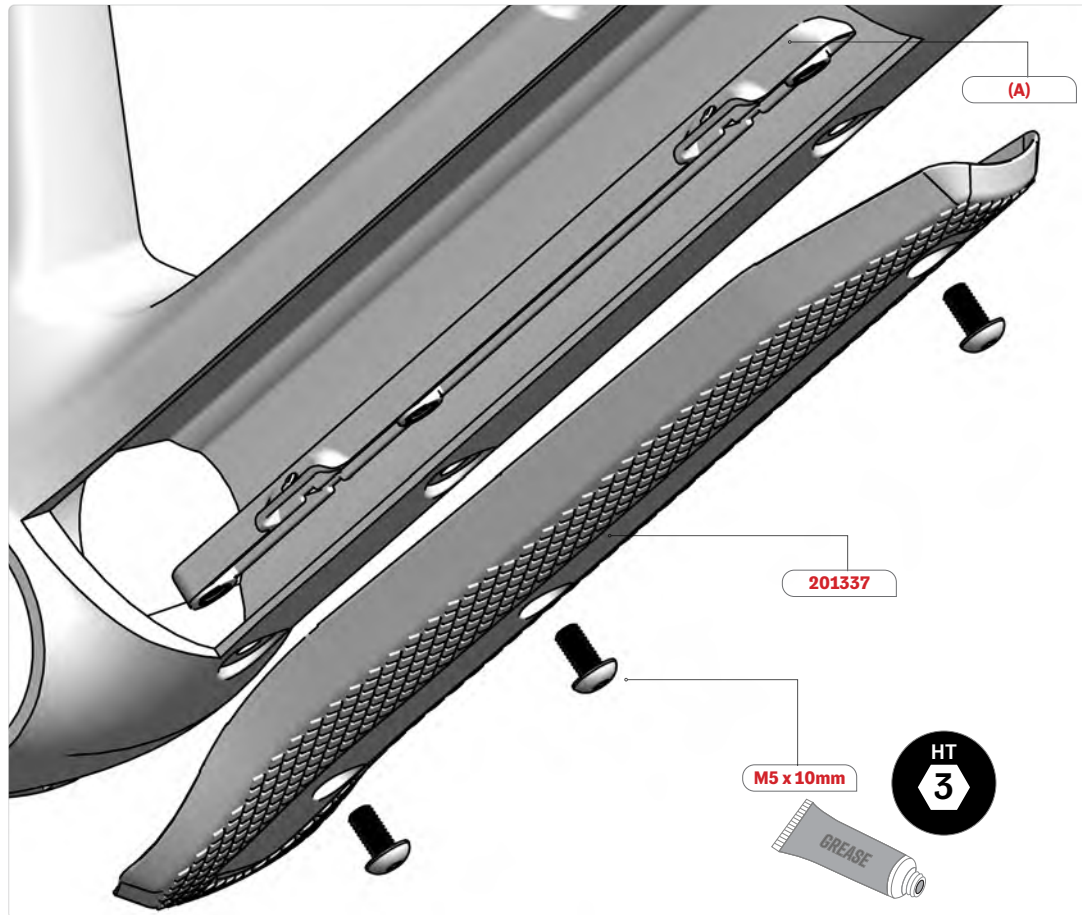

Assembling the Downtube Protector (SKU: 201337):

1. Apply grease to the threads of the three M5 x 10 mm button head screws.
2. Place the downtube protector holder (A) inside the frame by inserting in the DT door opening.
3. Hand-tight the three M5 x 10 mm screws, making sure the DT protector and holder are well positioned against the frame.

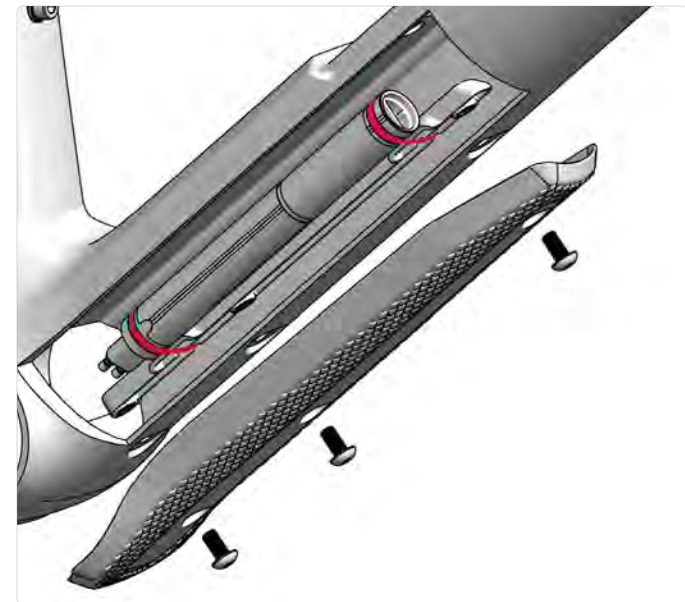

Assembling Di2 battery

1. Fix the Di2 battery on the holder before the installation of the downtube protector, using two cable-tie as shown.
2. Connect all Di2 cables in the battery and proceed with the downtube protector installation.

19. FORK INSTALLATION

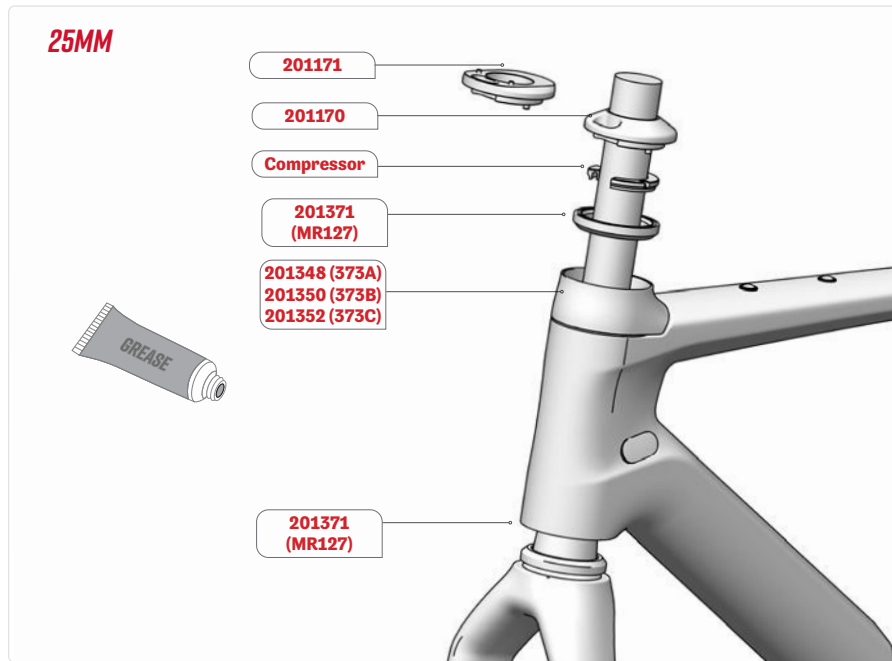

25mm assembly process (see 3D Headset Installation, p. 15):

1. Install the bottom bearing (MR127, SKU: 201371) on the fork. (Apply grease on both sides of the bearing)
2. Insert top bearing (supplied with the headset) in the headset column. (Apply grease on both sides of the bearing)
3. Slide the fork into the head tube while orienting all housing on the good side of the steerertube depending on the chosen headset system.
4. Install conical compressor ring once all cables are in place.
5. Install headset top spacer depending on the configuration (SKU: 201170 for SRS or 201171 for ACR) with all cable at the right place.
6. For more information on compatible systems and assembly suggestions, please see: [Internal Routing Guide](#) on our website.

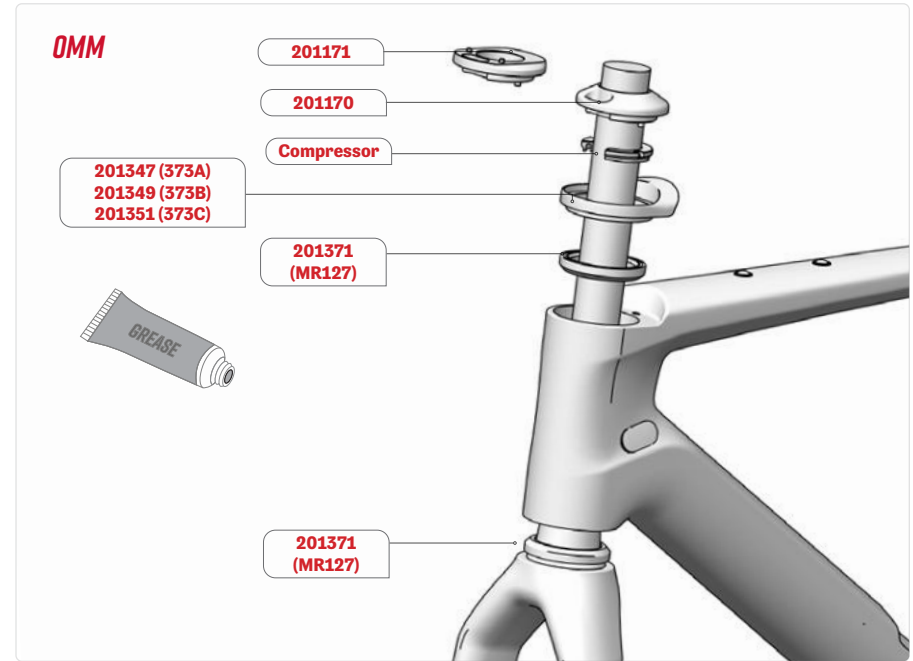

0mm assembly process:

1. Install the bottom bearing (MR127, SKU: 201371) on the fork. (Apply grease on both sides of the bearing)
2. Insert top bearing (MR127, SKU: 201371) in the frame upper bearing rest. (Apply grease on both sides of the bearing)
3. Push the 0mm Headset Cap (SKU: 201347, 201349 or 201351) on the frame upper bearing rest while aligning the pin in the frame hole.
4. Slide the fork into the head tube while orienting all housing on the good side of the steerertube. For SRS systems, we suggest that all cables pass on the same side of the steerer as the lever they are going to.
5. Install conical compressor ring once all cables are in place.
6. Install headset top spacer depending on the configuration (SKU: 201170 for SRS or 201171 for ACR) with all cable at the right place.



IMPORTANT:

Only 4 cables can pass through the headset per headset manufacturer recommendation.

20.1 TOOLBOX FRAME INSTALLATION

Assembling the door frame receptacle (SKU: 200821):

1. Apply threadlocker (no. 242) to the threads of the four M4 x 5 mm flanged button head screws.
2. Place the threaded part inside the frame in the upper hole.
3. Assemble the rounded top part and hand-tighten the two screws.
4. Repeat for the lower part.

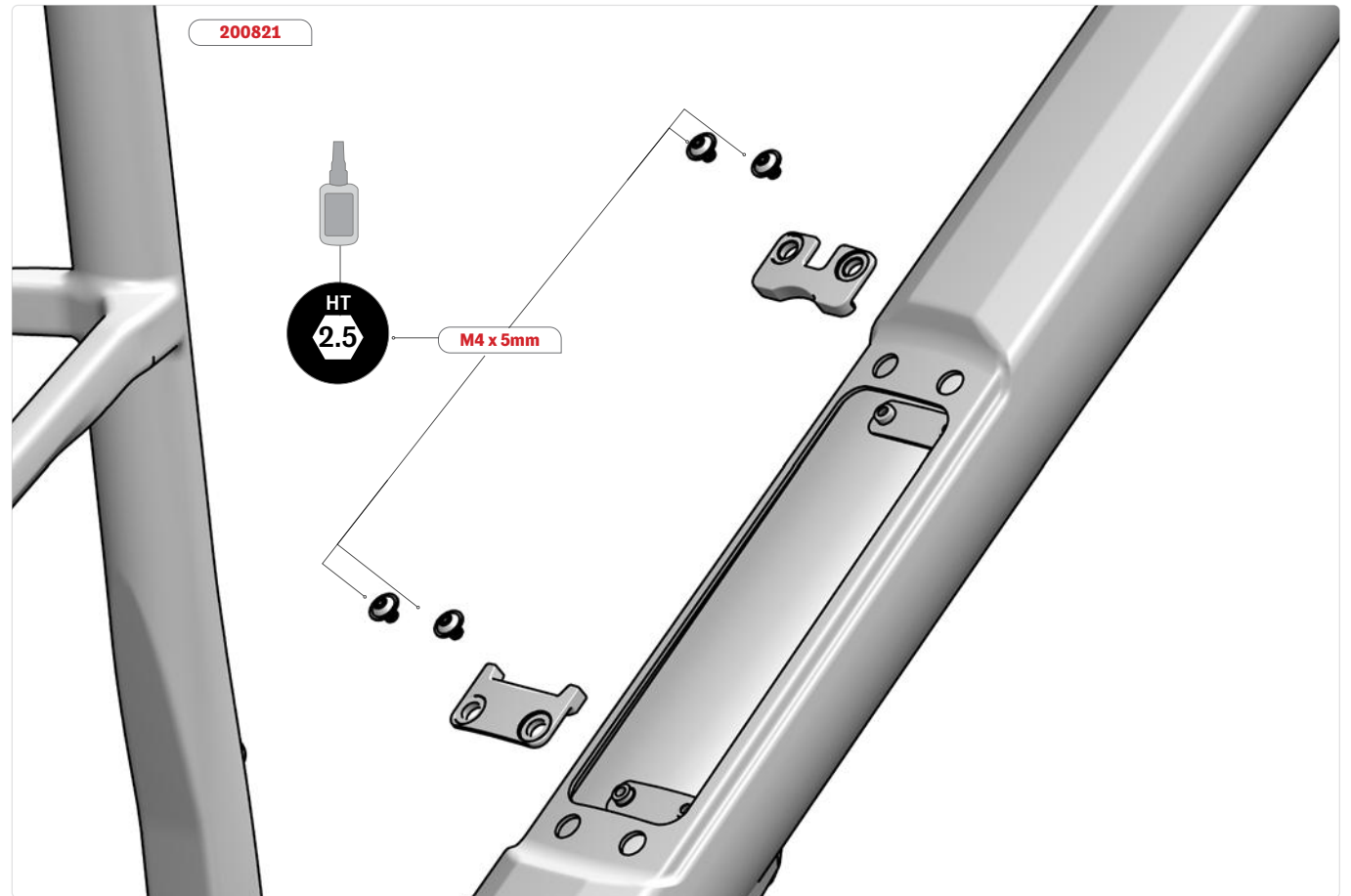

20.2 TOOLBOX DOOR ASSEMBLY

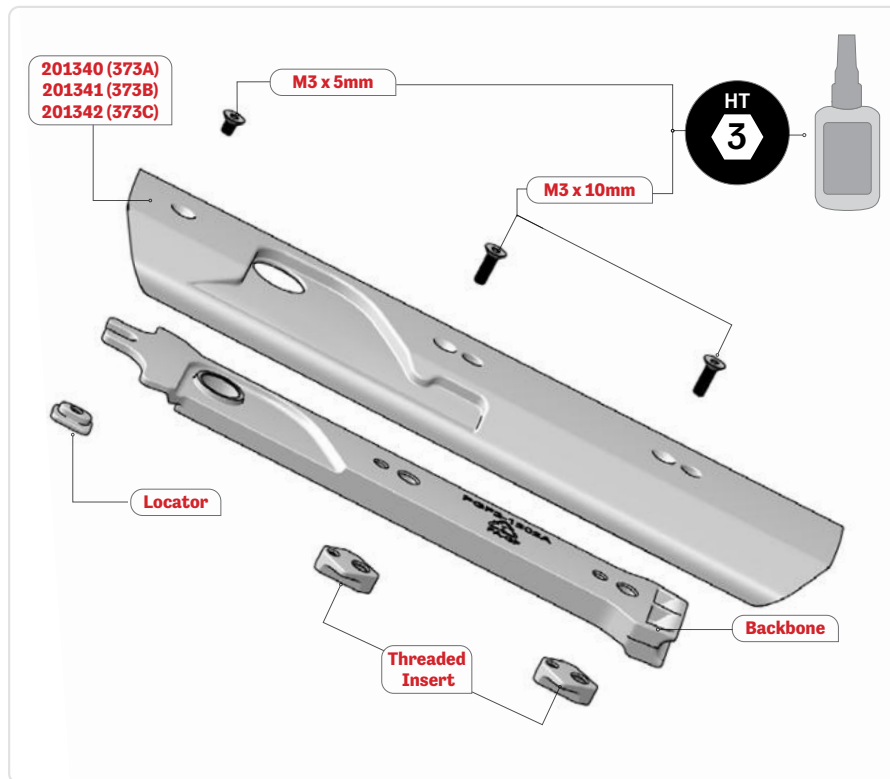

1. Apply a drop of blue threadlocker (no. 242) to the M3 x 5 mm screw threads.
2. Assemble the locator, backbone and door cover as shown with the M3 x 5 mm screw.
3. Apply a drop of blue threadlocker (no. 242) to the two M3 x 10 mm screw threads.
4. Assemble the threaded insert, backbone and door cover as shown with the two M3 x 10 mm screws.
5. Hand-tighten the three M3 screws.



1. Apply a drop of blue threadlocker (no. 242) to the M5 x 14 mm screw threads.
2. Assemble the rocker and lever on the door assembly as shown with the M5 x 14 mm screw. The matching interface is square; make sure the parts are aligned correctly.
3. Tighten the M5 x 14 mm screw to 3Nm.
4. Validate the rotation of the lever. There is a notch on the rocker to keep the lever in the open position.

20.3 TOOLBOX COMPONENTS

The Dark Matter comes with a downtube tool pouch.

Tools are **not** included, but here is a suggested toolkit and placement.

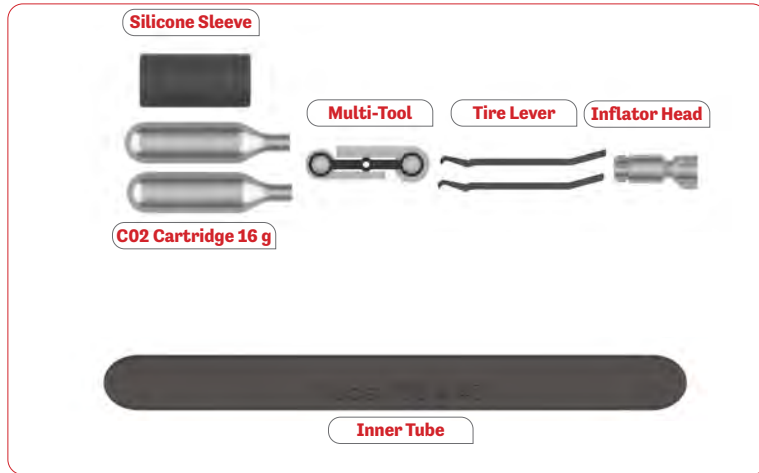

Tool Pouch



Suggested tool placement

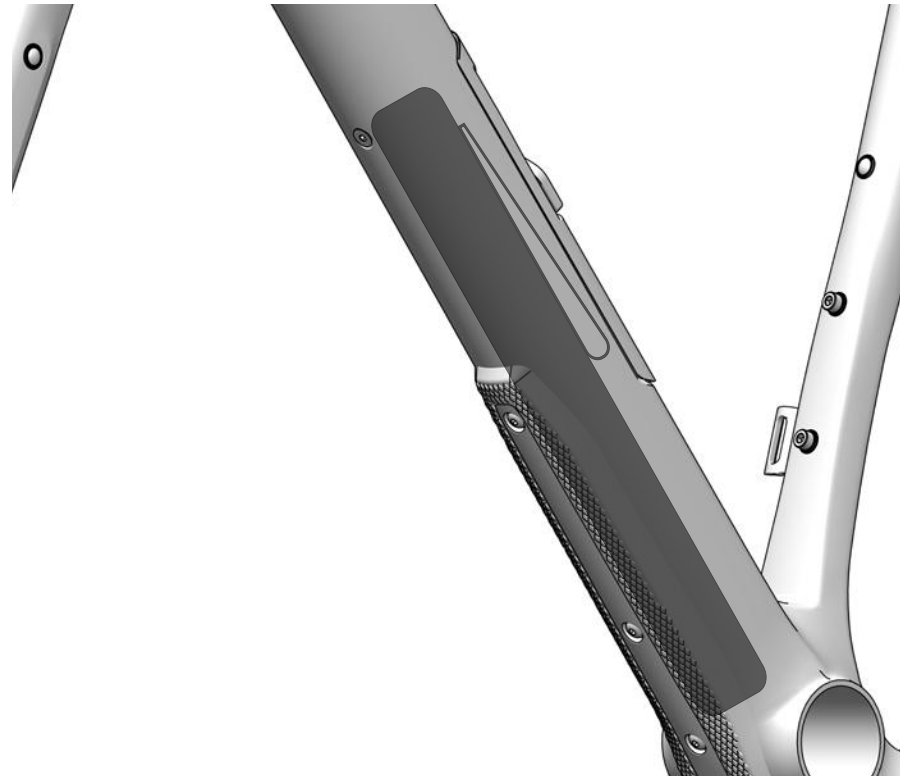

20.4 TOOLBOX DOOR INSTALLATION

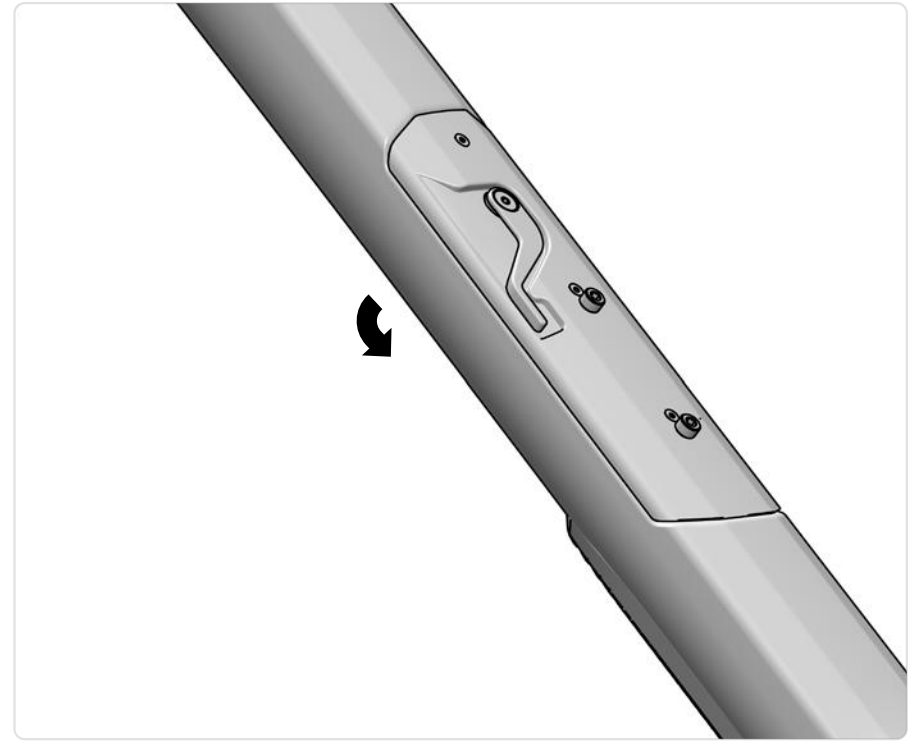
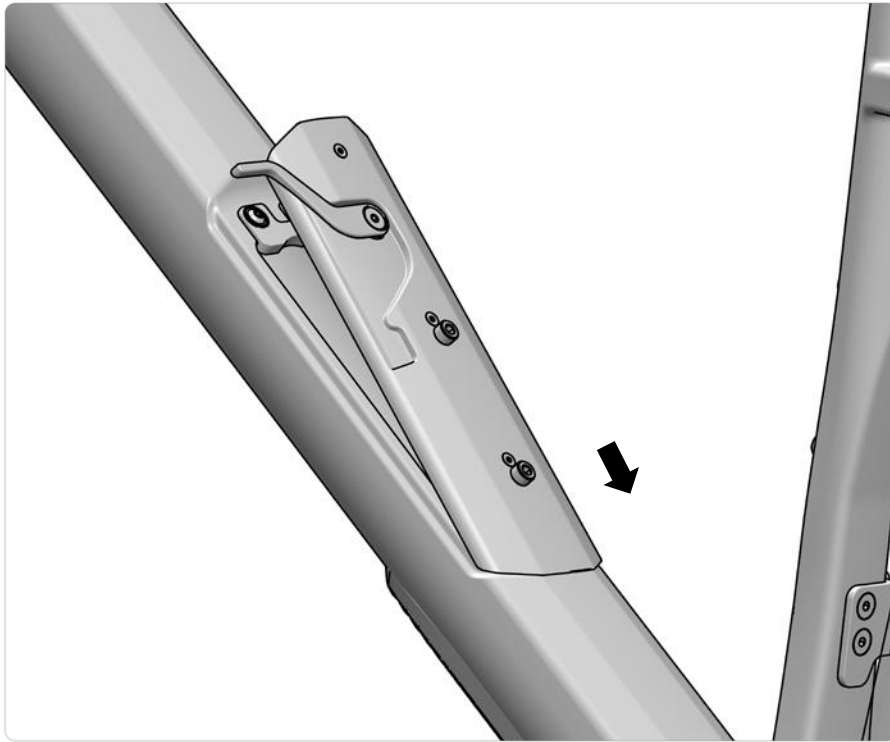

- 1.** Insert the door at an angle and make sure the backbone edges are aligned into the tab on the frame.
- 2.** Lower the door until it rest on the upper tab.
- 3.** Turn the lever 90 degrees counter-clockwise to lock the door in place.

21. BOTTLE CAGE POSITION

XXS



XS



S



M

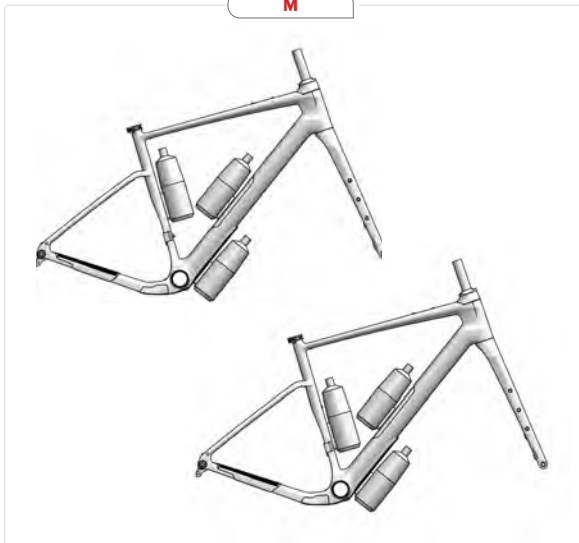

L

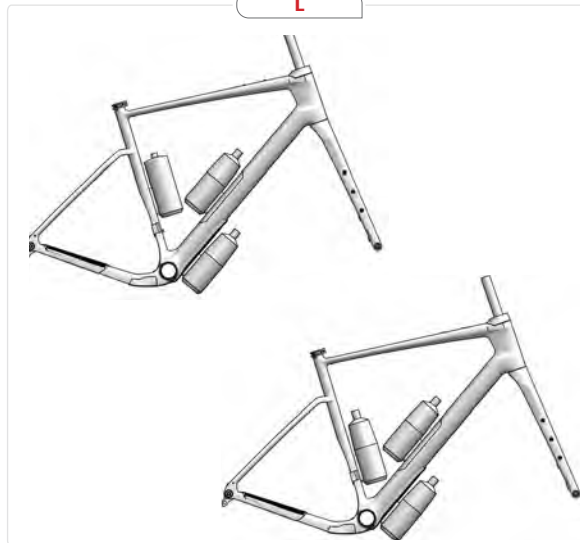

XL



Above are some possible options of how to fit the waterbottle(s) onto the frame's water-bottle-cage mounts, depending on the frame size.

22. CABLE AND HOUSING ROUTING - DYNAMO ROUTING



IMPORTANT:

Only 4 cables can pass thru the headset per headset manufacturer recommendation.



With a front light bracket on the fork:

1. Insert the dynamo cable in the fork right side, from the entry near the hub up to the hole under the fork's crown.
2. Insert the rear light cable from the hole under the top tube near the seat tube, out of the same hole under the fork's crown.
3. Use the front fender bracket (see p.37) to support the front light.



With a front light on the stem or handlebar:

1. Insert the dynamo cable in the fork right side, from the entry near the hub, out of the hole on the steerer tube, then up to the top of the headtube.
2. Insert the rear light cable from the hole under the top tube near the seat tube, out of the top of the headtube.
3. Follow the handlebar / stem and light manufacturer installation procedure for the rest.

23.1 REAR RACK AND FENDER INSTALLATION

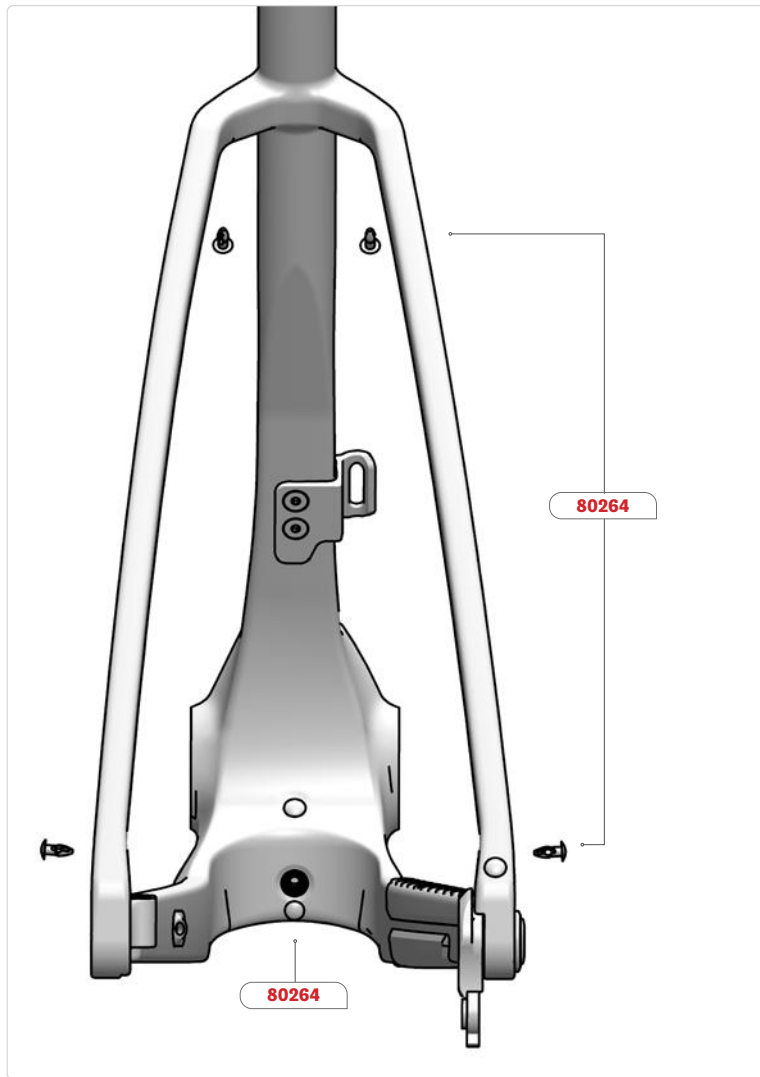

Without fender or rack:

1. Cover the five unused holes with M5 plugs (SKU: 80264).

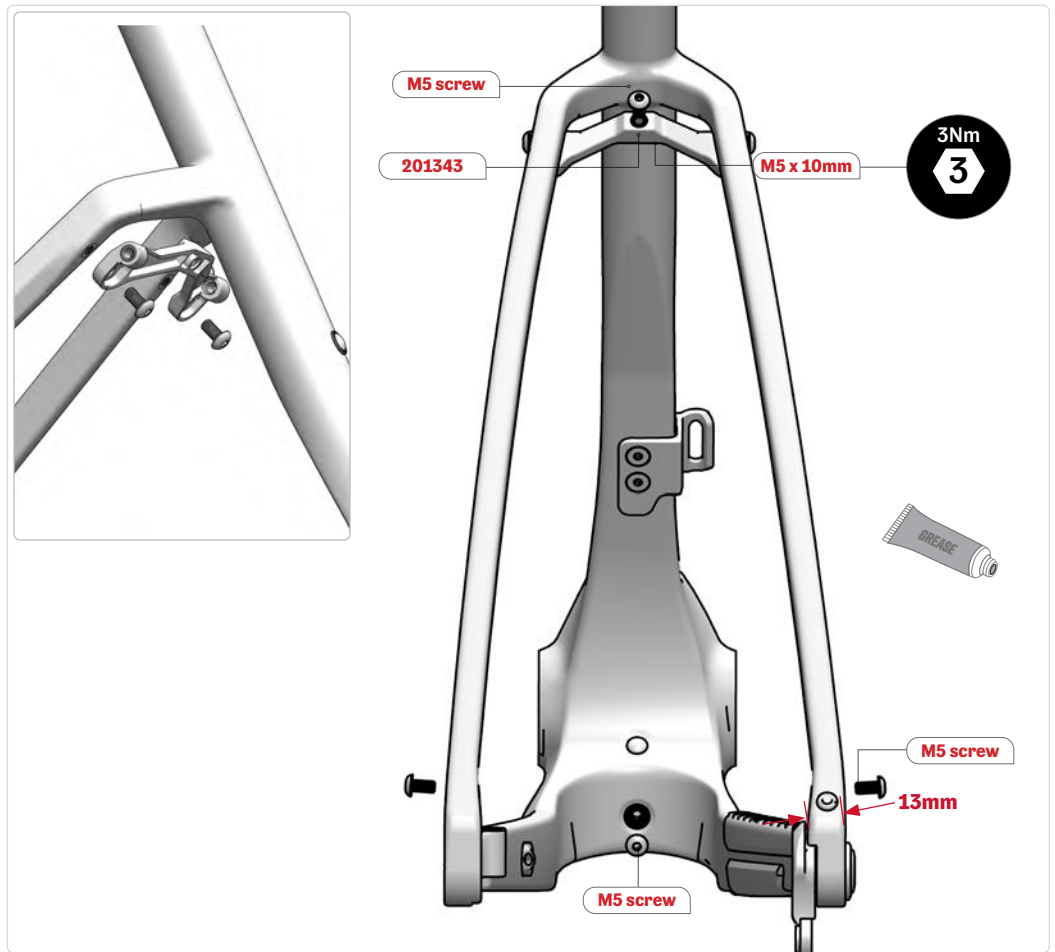

With fender only:

1. To install a rear fender, use the fender bracket kit (SKU: 201343). Use the two supplied M5 x 10mm button head screws to secure the bracket.
2. When securing the fender on the dropout, make sure that the screw doesn't interfere with the chain. The maximum insertion of the screw is 13mm to avoid protrusion and possible chain interference.
3. All screws must be torqued to a maximum of 3Nm. Apply grease to the threads.

23.2 REAR RACK AND FENDER INSTALLATION

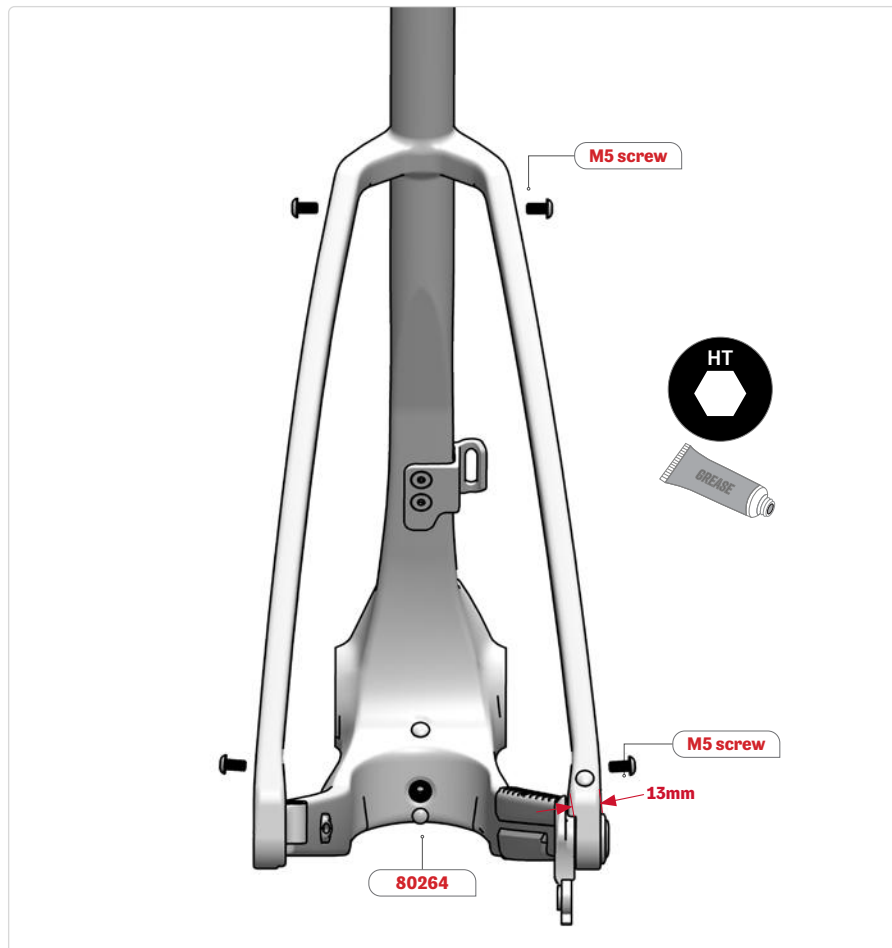

With rack only:

1. When securing the rear rack on the dropout, make sure that the screw doesn't interfere with the chain. The maximum insertion of the screw is 13mm to avoid protrusion and possible chain interference. Make sure there is at least 10mm of screw insertion to support the load.
2. All screws must be torqued to a maximum of 3Nm. Apply grease to the threads.
3. Cover the unused hole with a M5 plug (SKU: 80264).

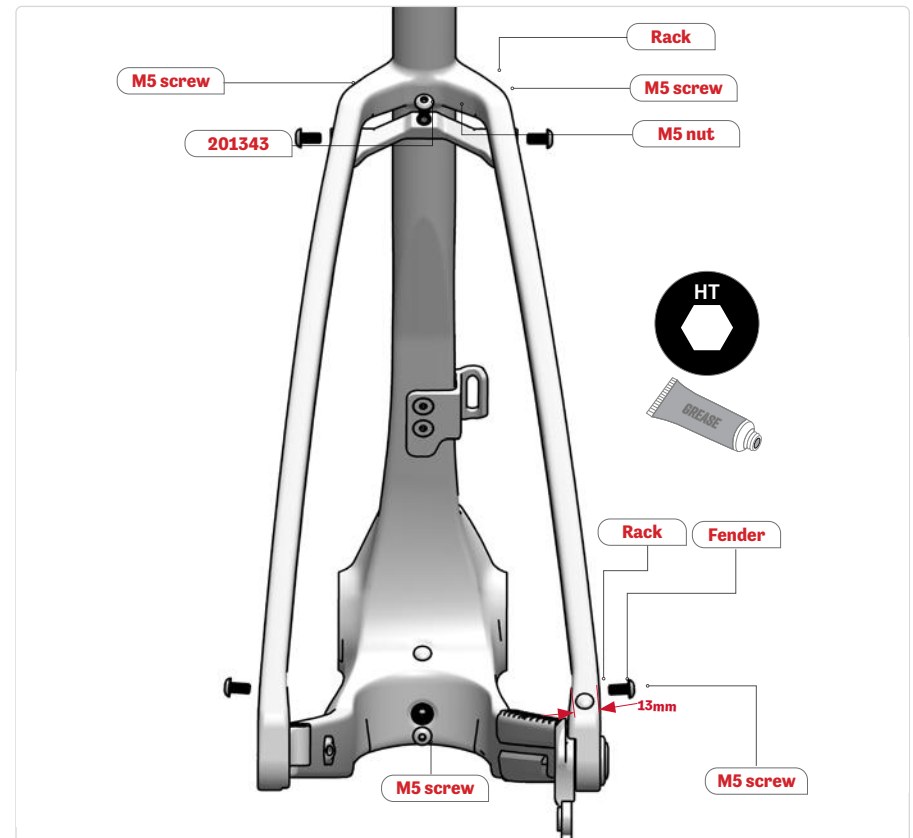

With fender and rack:

1. To install a rear fender and a rack, use the fender bracket kit (SKU: 201343). Use two M5 screws and nuts to secure the bracket to the rack upper support.
2. When securing the fender and the rear rack on the dropout, make sure that the screw doesn't interfere with the chain. The maximum insertion of the screw is 13mm to avoid protrusion and possible chain interference. Make sure there is at least 10mm of screw insertion to support the load.
3. If possible, screw the fender onto the rear rack. If not possible, position the rear rack between the frame and the fender on the screw.
4. All screws must be torqued to a maximum of 3Nm. Apply grease to the threads.

24. FRONT FENDER INSTALLATION

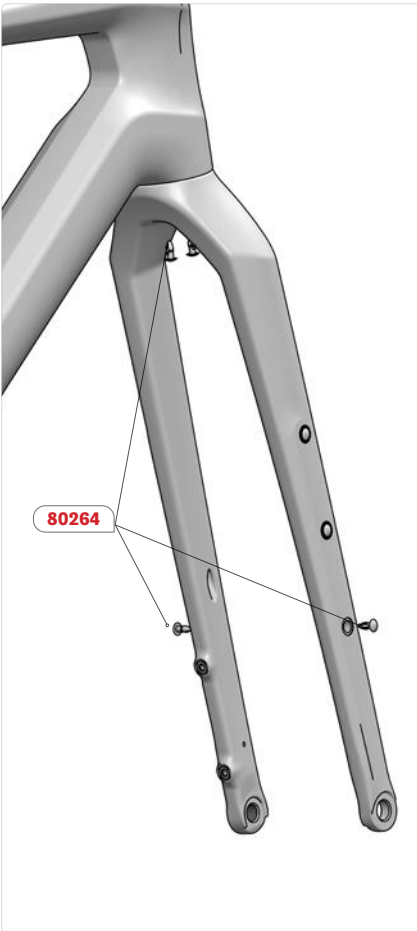
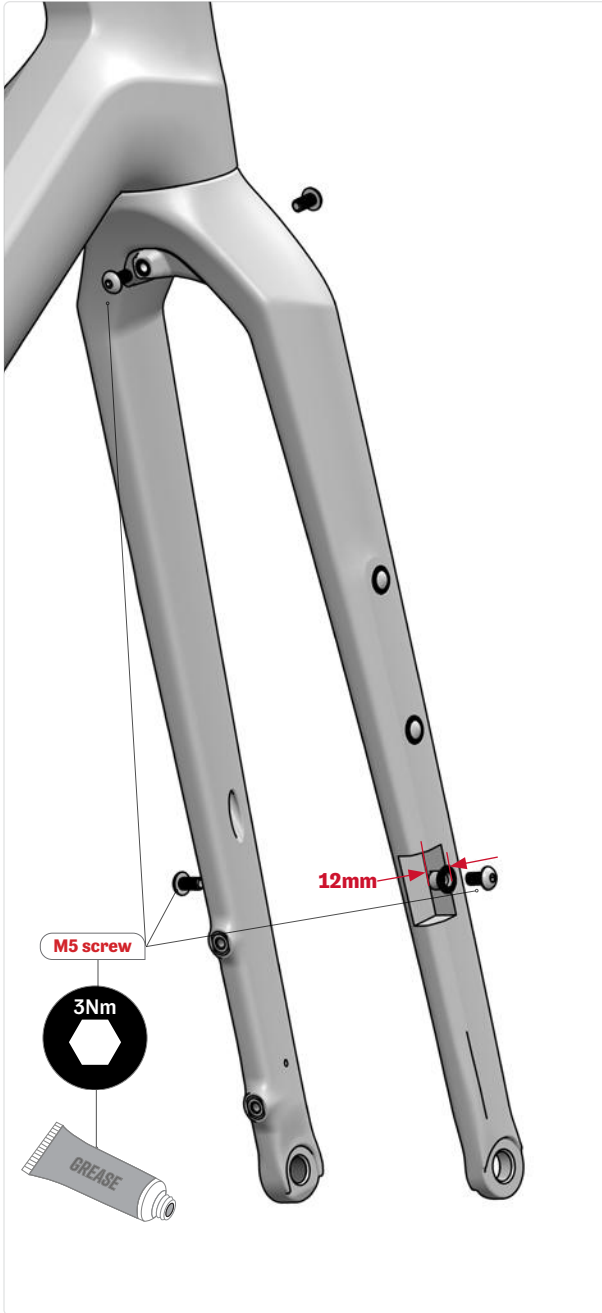

- To install a front fender, use the front fender bracket kit (SKU: 201344). Use the supplied M5 x 14 mm button head screw to secure the bracket.
- Make sure the top screw securing the fender doesn't touch the fork.
- The thread insertion on the interior hole for fenders is 12mm. Ensure 12mm or less of visible threads once the fender is screwed on.
- All screws must be torqued to a maximum of 3Nm. Apply grease to the threads.
- Cover all unused holes with M5 plug (SKU: 80264)

