







- 1. Tools Needed & First Aid Kit ..... 3
- 2. E-117 TRI Disc 317A Frameset Parts ..... 4
- 3. E-117 TRI Disc 317A Parts' SKUs and Descriptions\*..... 5
- 4. Seat Post Clamp Installation ..... 6
- 5. Seat Post Installation..... 7
- 6. Seat Post Installation..... 8
- 7. Frame Inspection ..... 9
- 8. Rear Derailleur Hanger Adjustment ..... 10
- 9. Front Derailleur Hanger Adjustment ..... 11
- 10. Headset Installation ..... 12
- 11. Cable Housing Installation for mechanical drive train..... 15
- 12. Cable Housing Installation for electrical drive train..... 16
- 13. Cable Housing Installation ..... 17
- 14. Rear derailleur grommet ..... 19
- 15. Electronic Drive-train Installation..... 20
- 16. Saddle Adjustment ..... 21
- 17. Troubleshooting / Tips ..... 22
- 18. Min/Max Seat Post Insertion ..... 23

My E-117 Tri Disc

Date of purchase: \_\_\_\_\_

Retailer: \_\_\_\_\_

Size: \_\_\_\_\_

Serial Number: \_\_\_\_\_

*For the warranty to be valid, the bicycle must be fully assembled by an authorized Argon 18 dealer. High end components, particularly carbon parts, need extra care when assembled. These components must be installed using a calibrated torque wrench to make sure every bolt is at the right torque setting to prevent damage.*



## Tools needed for assembly

- 1: Bearing Cup Press (Park Tool HHP-2)
- 2: Allen Key Set
- 3: Grease
- 4: Utility Pick Set (Park Tool Item # UP-SET)
- 5: Clean Rags
- 6: Derailleur Hanger Alignment Gauge (Park Tool Item # DAG-2,2)
- 7: Cables and Housing Cutter
- 8: Carbon Paste
- 9: Loctite #242 or #243
- 10: Torque Wrench

## First Aid Kit: Essential parts to always have on hand IN CASE OF EMERGENCY...THIS MIGHT SAVE YOUR RIDE!

- 1: Spare rear dropout (SKU: 80832 for Direct Mount and 80802 for regular)
  - 2: Spare brake pads corresponding to your caliper and disc model
  - 3: Seat clamp (SKU: 80423, 80422)
- IMPORTANT: the E-117 Tri Disc's seat clamp (1.5-1.6) is not the same as the Nitrogen

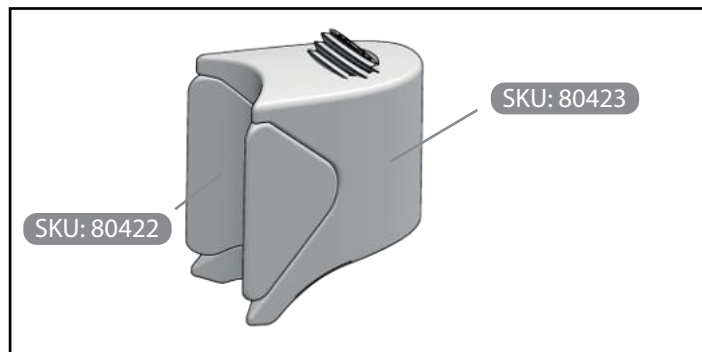

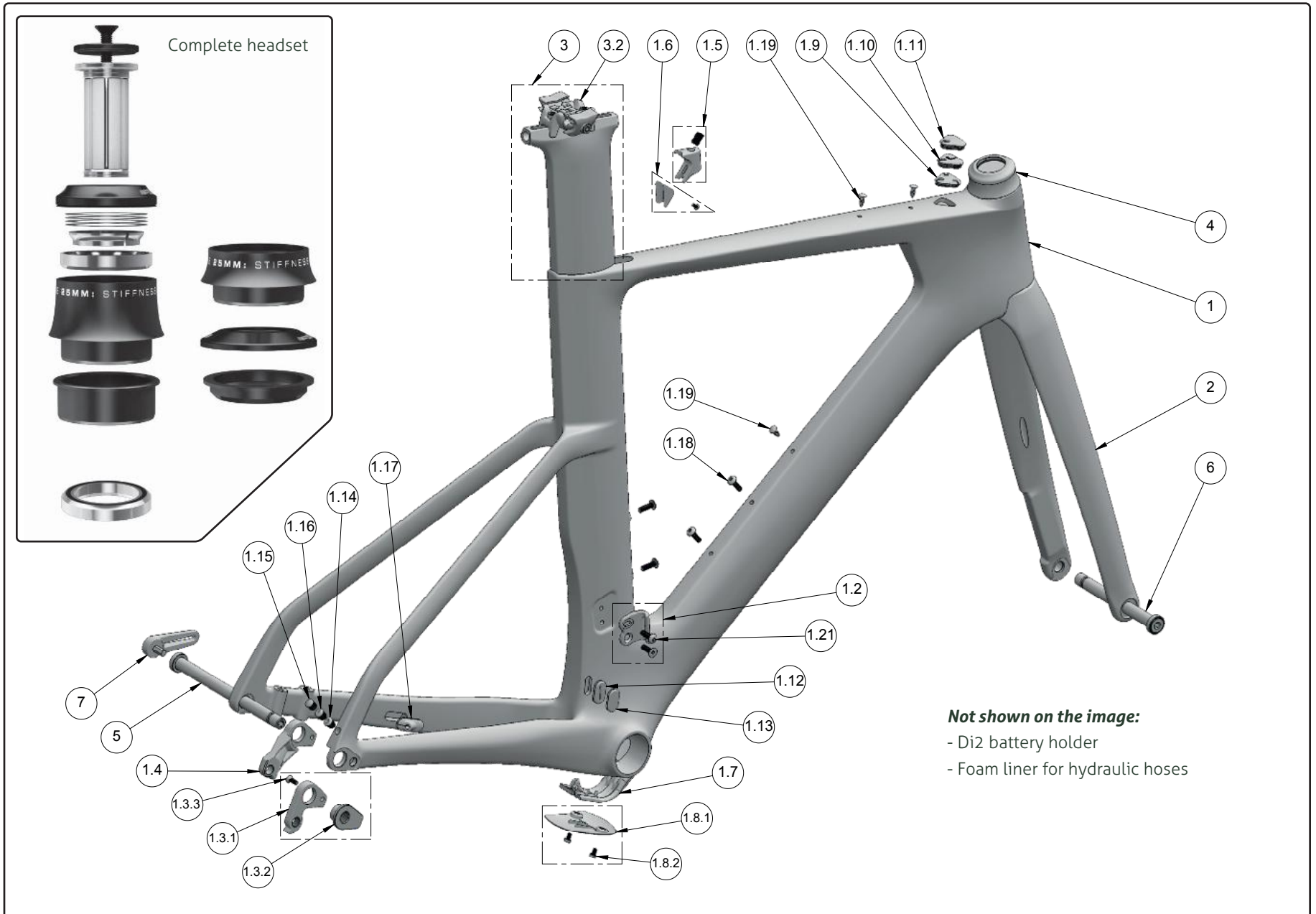

**Not shown on the image:**  
 - Di2 battery holder  
 - Foam liner for hydraulic hoses

### 3. E-117 TRI Disc 317A Parts' SKUs and Descriptions\*

# ARGON 18



No.	Name	A18 SKU#	Qty
1	E-117 TRI DISC FRAME	N/A	1
1,2	FRONT DERAILLEUR HANGER (W. SCREWS)	38882	1
1,3,1	REAR DERAILLEUR HANGER STANDARD	80802	1
1,3,2	REAR DROPOUT DS		1
1,3,3	REAR DERAILLEUR HANGER SCREW M4x12 FLAT HEAD		1
1,4	REAR DERAILLEUR HANGER DIRECT MOUNT	80832	1
1,5	SEAT POST COLLAR BASE W. SCREW M8X12	80423	1
1,6	SEAT POST COLLAR WEDGE W. SCREW M3X8	80422	1
1,7	BB CABLE GUIDE	80492	1
1,8,1	BB CABLE COVER	80159	1
1,8,2	BB CABLE COVER SCREW M4x6		2
1,9	TT GROMMET MECH	36656	1
1,10	TT GROMMET Di2	36670	1
1,11	TT GROMMET WIRELESS	81094	1
1,12	FD CABLE ENTRY GROMMET	80164	1
1,13	FD CABLE ENTRY PLUG	80826	1
1,14	ROUND GROMMET MECH	80985	1
1,15	ROUND PLUG	80804	1
1,16	ROUND GROMMET DI2	80805	1
1,17	OBLONG HOSE GUIDE	80551	1
1,18	SCREW FOR BOTTLE CAGE AND FRONT DERAILLEUR M5x16 ROUND HEAD	81003	5
1,19	PLASTIC PLUG M5	80264	3
2	E-117 TRI DISC FORK	FK.E117T_D.317A	1
3	E-117 TRI ASP-7050 SEAT POST (INCL. SHAFT + HEAD)	SPE117T.285A	1
3,2	RITCHEY SEAT POST HEAD	N/A in spare part; Available at ritcheylogic.com	1
3,3	DI2 BATTERY HOLDER	80167	1 kit
4	HEAD SET NO.37-E	80096	1
5	A18 REAR THRU AXLE M12x161	81053	1
6	A18 FRONT THRU AXLE M12x119	81052	1
7	A18 THRU AXLE LEVER	81054	1
8	FOAM LINER FOR HYDRAULIC HOSE	80811	1

\*Except for the frame itself, which is not sold as a spare part, all parts can be ordered by referring to their respective SKU number.

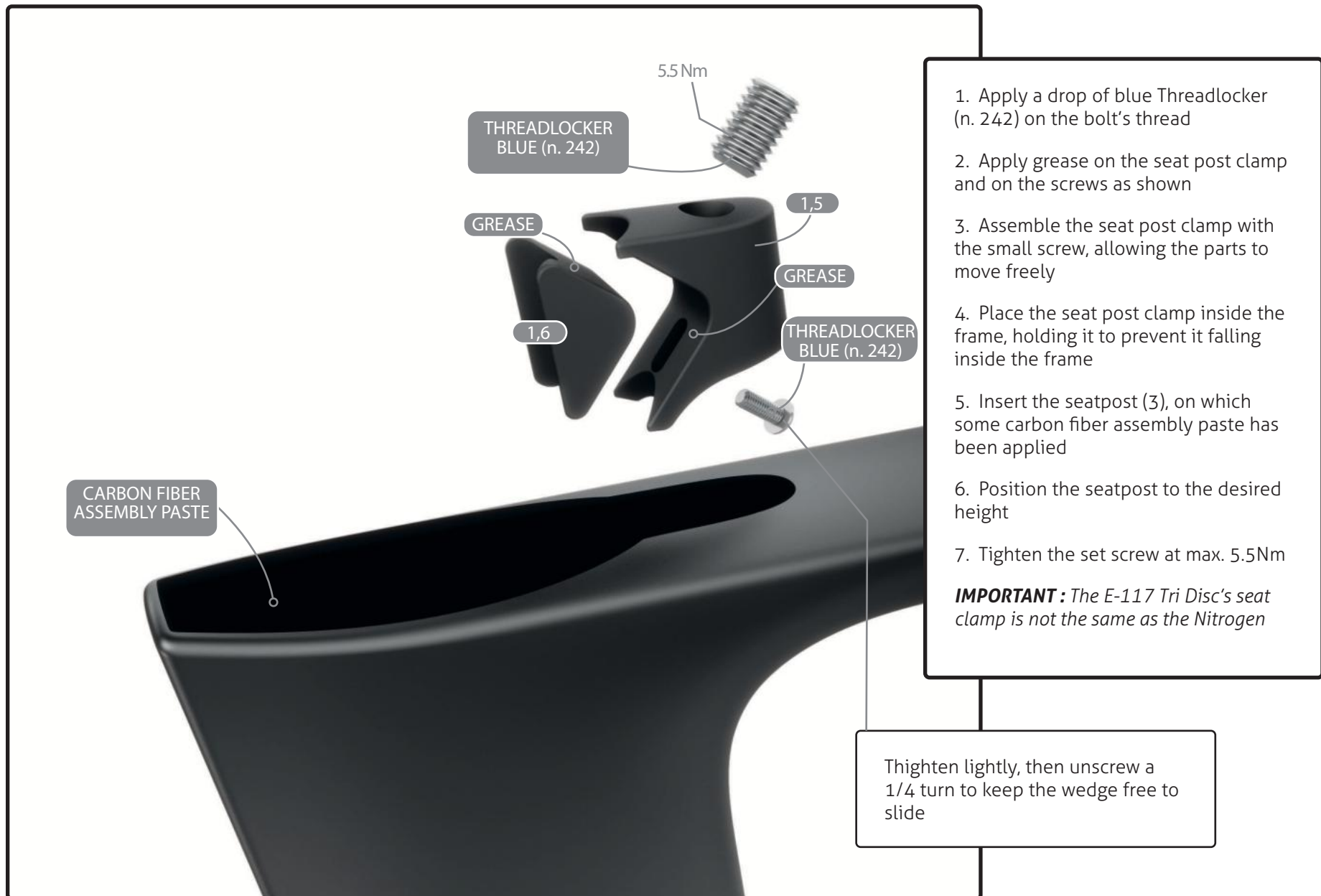

1. Apply a drop of blue Threadlocker (n. 242) on the bolt's thread
2. Apply grease on the seat post clamp and on the screws as shown
3. Assemble the seat post clamp with the small screw, allowing the parts to move freely
4. Place the seat post clamp inside the frame, holding it to prevent it falling inside the frame
5. Insert the seatpost (3), on which some carbon fiber assembly paste has been applied
6. Position the seatpost to the desired height
7. Tighten the set screw at max. 5.5Nm

**IMPORTANT:** The E-117 Tri Disc's seat clamp is not the same as the Nitrogen

Tighten lightly, then unscrew a 1/4 turn to keep the wedge free to slide

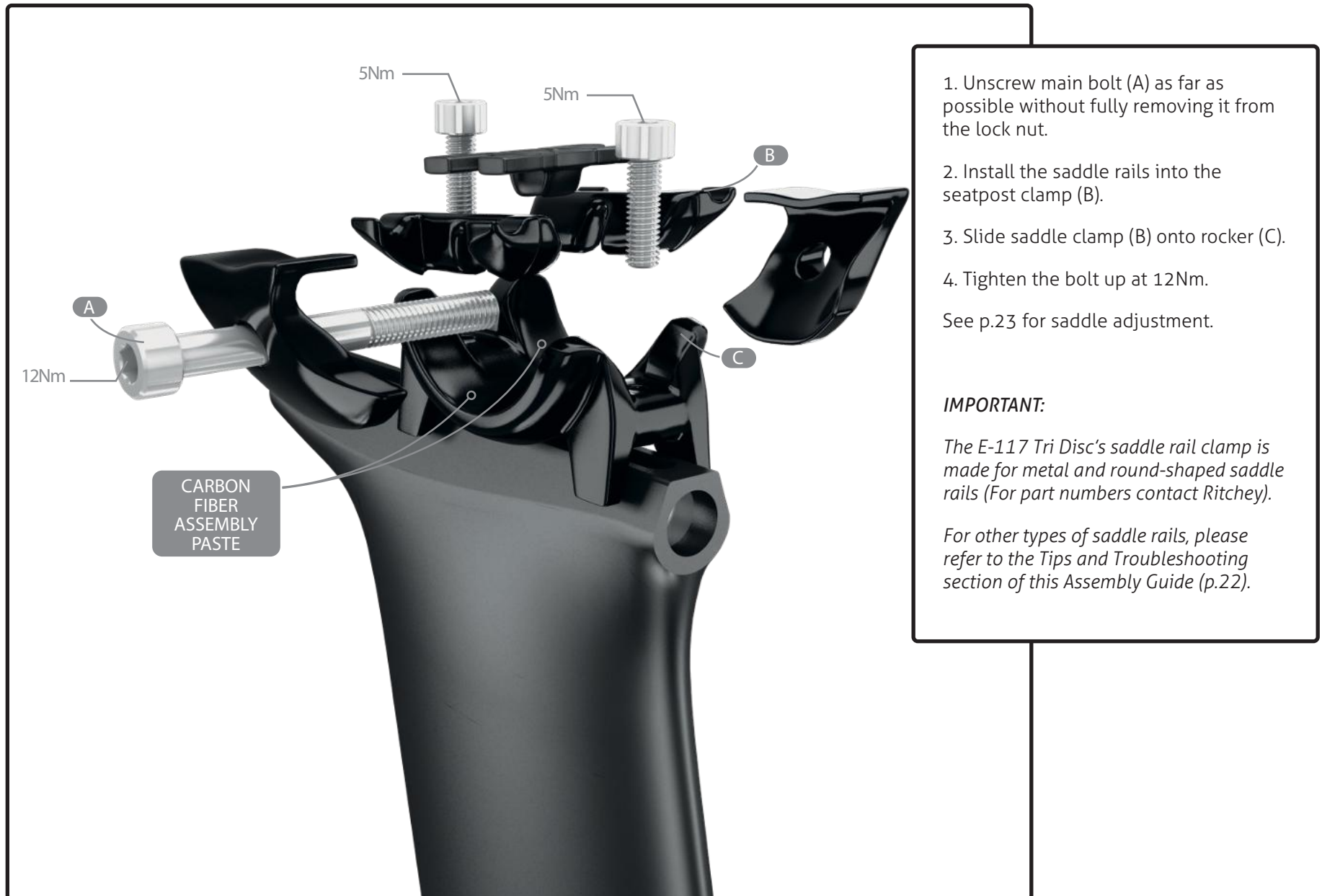



The Di2 battery is hidden in the seatpost; use the Di2 battery holder (3.3) to fix the battery correctly. Apply a slight amount of grease on both parts.



*BEFORE ASSEMBLING YOUR NEW E-117 TRI DISC, MAKE SURE THAT YOU HAVE ALL THE FOLLOWING:*

1. Brakes hoses, gears cables and housing set
2. Frameset parts checklist (see p.5)
- 3: All the necessary bolts (refer to Frameset Parts, p.5)

*WHEN ASSEMBLING YOUR NEW E-117 TRI DISC, MAKE SURE YOU FOLLOW THIS PROCEDURE:*

- 4: Inspect the frame for cosmetic aspect (scratches, bumps, cracks, paint defect, etc.)
- 5: For reference, check serial number and write it on p.2
- 6: For optimal shifting performance, use a dropout alignment gauge to make sure that the drive-side dropout is straight.

**IMPORTANT:**

**The following parts are assembled on the frame. When assembling the bike, you will need to adjust these parts according to their torque specifications.**

Parts installed on the frame	Description	Screw type	Torque Nm	Detail
Front derailleur hanger	Screw (2)	5mm	4Nm	Threadlocker
Rear derailleur hanger	Screw (1)	4mm	2Nm	Threadlocker
Bottle cage	Screw (4)	5mm	3Nm	Grease
Bottom bracket cover	Screw (2)	4mm	2.5Nm	Grease



1. Select the correct rear derailleur hanger depending on the type of derailleur that you have.

- Direct mount (1.4)
- Regular mount (1.3.1)

2. Make sure to align the rear derailleur hanger using a Derailleur Hanger Alignment Gauge like Park Tool Item #DAG-2,2.

For any assistance, visit Park Tool's website:

[www.parktool.com/product/derailleur-hanger-alignment-gauge-dag-2-2](http://www.parktool.com/product/derailleur-hanger-alignment-gauge-dag-2-2)



The front derailleur hanger can be adjusted according to the front derailleur angle in order to get an equal curve between the derailleur and the big chain ring. Once at the right angle, use blue 242 Loctite and screw in at 4Nm.



THREADLOCKER

4Nm

4Nm



Install the 3D headset (4) according to the pressfit assembly guide. You can choose from 3 different heights: 25mm, 15mm, or 0mm.

**IMPORTANT:**

*No more than 30mm of spacers can be placed between the stem and the top cap of the 3D system.*

*The steerer must be trimmed no more than 5mm above the stem. The use of more than 5mm of spacers above the stem could void the efficiency of the compressor.*

*These practices will automatically cancel any warranty claim against the manufacturer.*





## STEP 1

First, you must assess which setup suits your needs: **25mm, 15mm or 0mm.**

## STEP 2

Inspect the bike's head tube for any sharp edges and apply a small amount of grease.

## STEP 3

For the **25mm and 15mm** setups, lightly grease the bottom section of the 3D bearing holder (6) and insert the plastic sleeve (7).

## STEP 4

Position the headset inside the head tube. Place the top 3D assembly with the headset bearing inside (this will prevent the sleeve from getting damaged). Add the compression ring (4) on top of the bearing, then add the press fit 3D system tool and softly press down the assembly until it bottoms out using a Bearing Cup Press (**Park Tool HHP-2**). Then, insert the bottom bearing (5), micro spacers (3) and top cap (2), slide the fork and stem and measure the steerer length needed.

For the **0mm setup**, do not use the plastic sleeve. Install the 3D bearing holder (6) with grease applied directly inside the frame.



To remove the 3D bearing holder, insert the **Park Tool RT-1** and then tap it carefully until the spacer comes out.

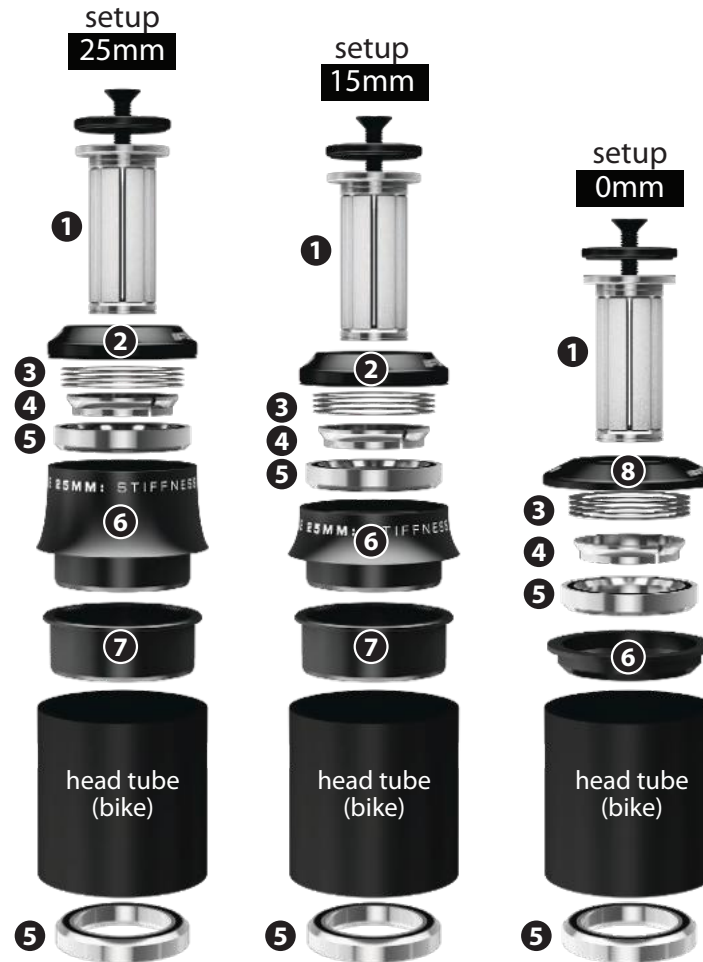

- 1 Compressor
- 2 Top cap
- 3 Micro spacers
- 4 Compression ring
- 5 Bearing
- 6 3D bearing holder
- 7 Plastic sleeve (no need for **0mm** setup)
- 8 Top cap for **0mm** setup

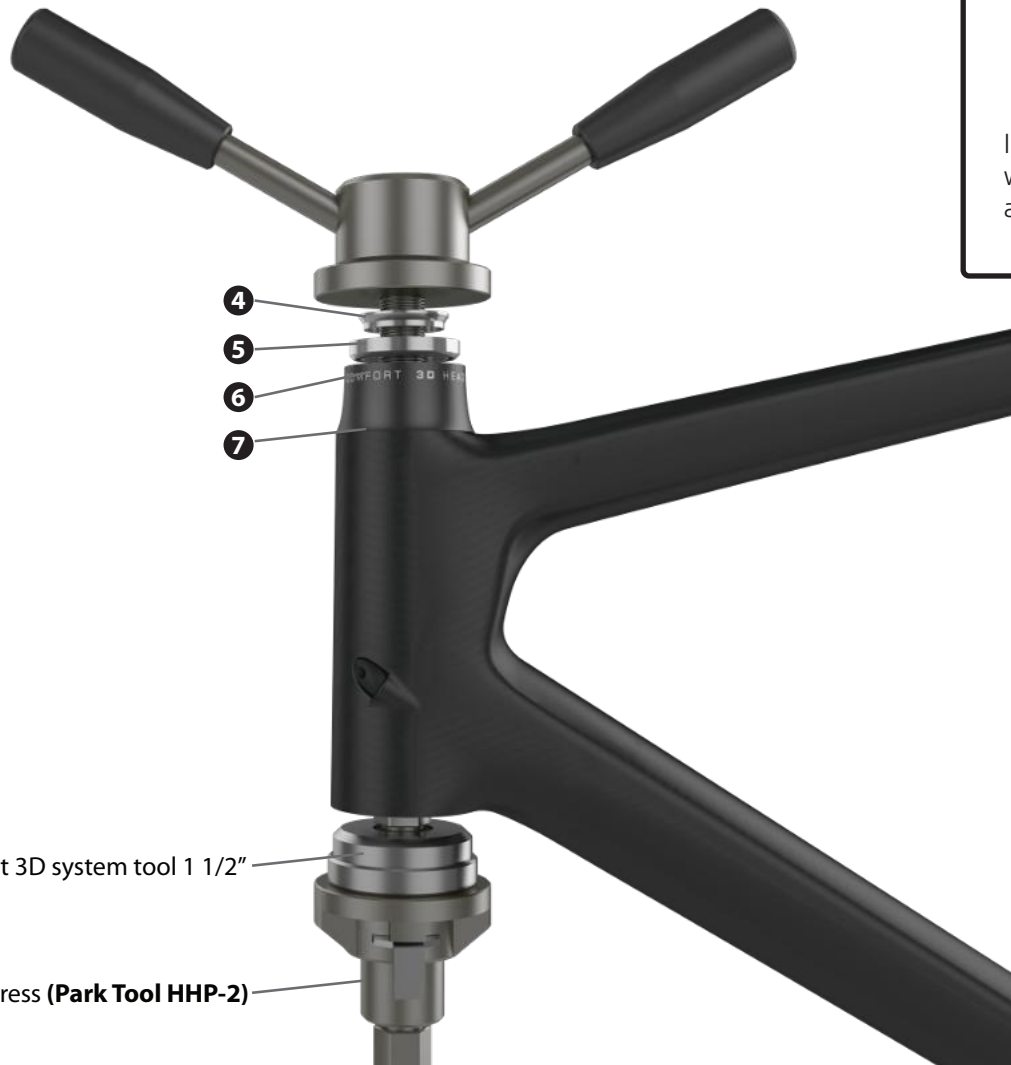

  
IMPORTANT : Use the Press Fit 3D system tool 1 1/2" with the Bearing Cup Press (ParkTool HHP-2) to avoid any damage on the bike frame.

- 1 Compressor
- 2 Top cap
- 3 Micro spacers
- 4 Compression ring
- 5 Bearing
- 6 3D bearing holder
- 7 Plastic sleeve (no need for 0mm setup)
- 8 Top cap for 0mm setup

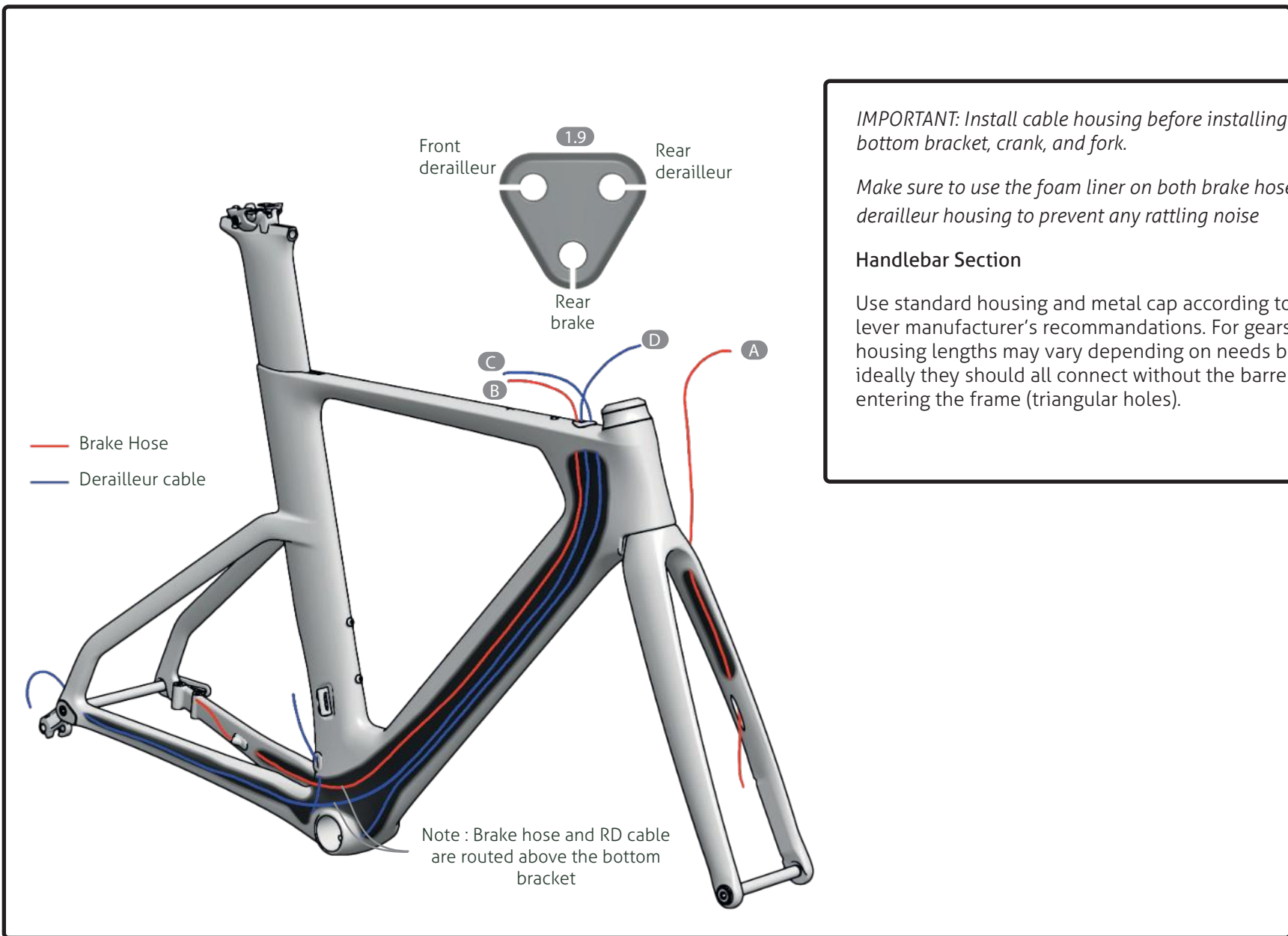

*IMPORTANT: Install cable housing before installing the bottom bracket, crank, and fork.*

*Make sure to use the foam liner on both brake hose and derailleur housing to prevent any rattling noise*

**Handlebar Section**

Use standard housing and metal cap according to lever manufacturer's recommendations. For gears, housing lengths may vary depending on needs but ideally they should all connect without the barrels entering the frame (triangular holes).

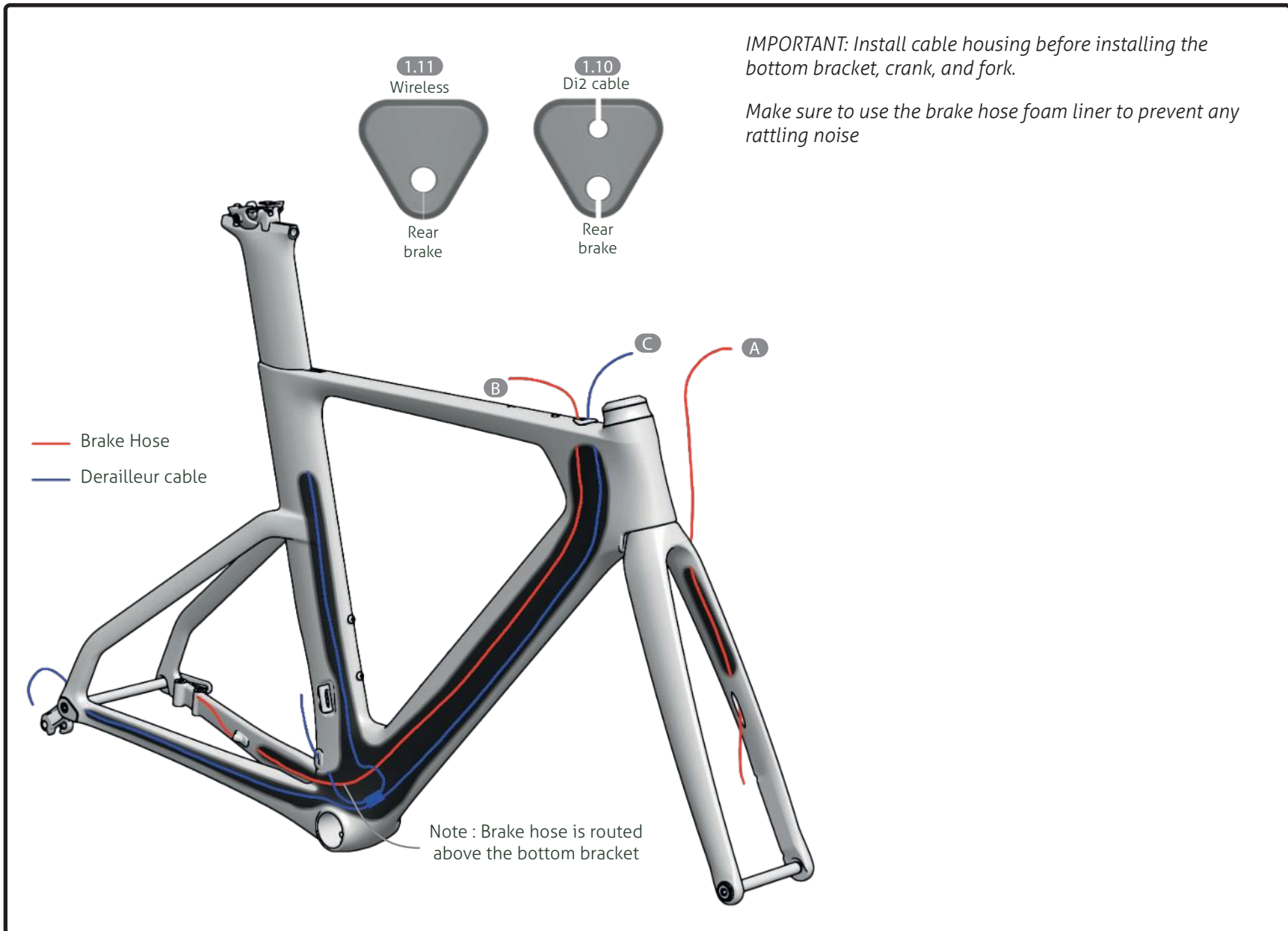



### Bottom Bracket Section

1. Measure approximately 660mm length (for a medium-sized frame) of one unit of LEX 4mm gear housing (mechanical) for the front derailleur.
2. Install plastic caps at each tip of the gears' housings.
3. Remove the cable guide (1.7) under the bottom bracket.
4. Connect the housing length to the bottom bracket's guide according to inscriptions (FD: Front Derailleur).

NOTE: The RD and RB features on the cable guide (1.7) are not used on the E-117 Tri Disc model. Full housing are to be used for the rear derailleur and rear brake inside the frame.





5. Pass the cable housings inside the downtube until they come out the top tube.
6. Be sure that the guide's pin is inside the frame's hole.
7. With a hook take the housings out of the frame by the top tube's triangular hole.
8. Install 4mm barrel on gear housing.

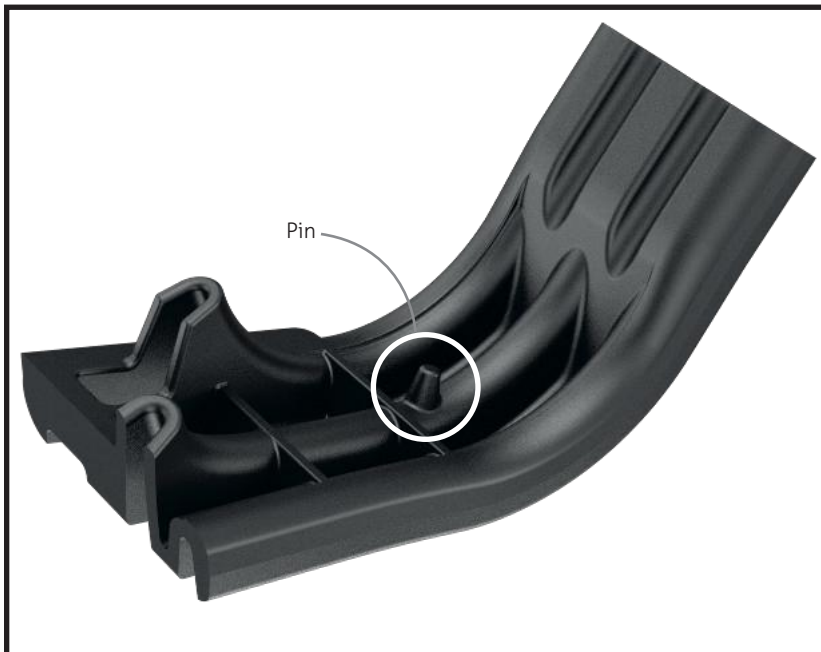

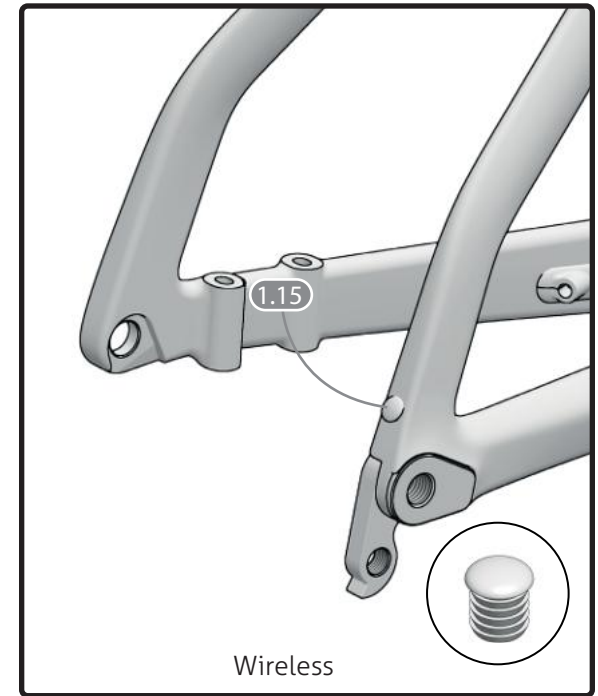
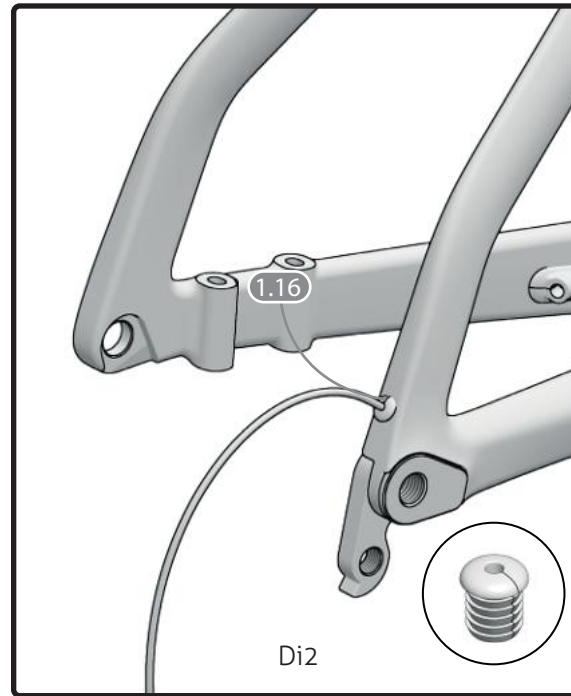
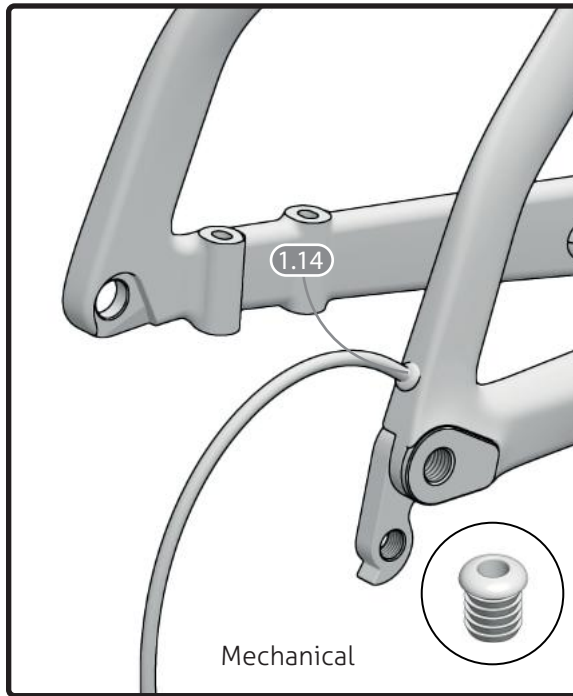

**IMPORTANT:**

For the Di2 cable section that runs through the drive side chainstay, use the preinstalled tube guide that is supplied with the frame.

Use the proper cable grommet to fix the rear derailleur cable correctly depending if you use mechanical drive-train (1.14) or electronic shifting (1.15/1.16).

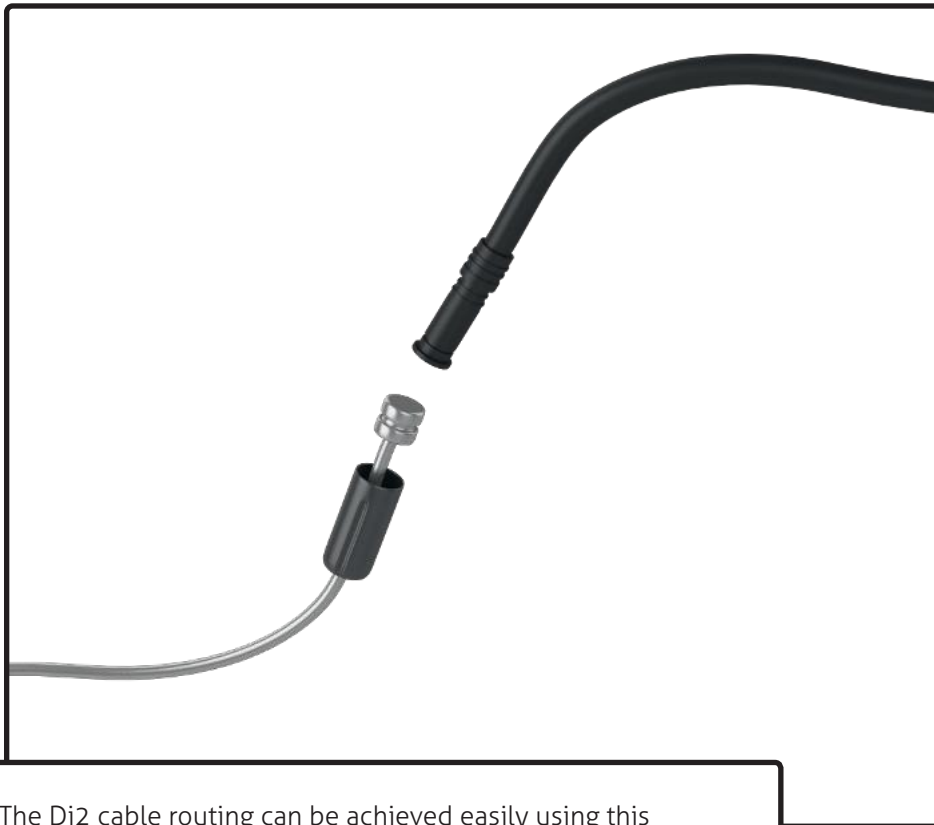

The Di2 cable routing can be achieved easily using this simple trick: use a gear cable and a metal cable end to fix the Di2 cable. For more information on Shimano Di2 electronic system installation, go to: [si.shimano.com](http://si.shimano.com).



For horizontal adjustment:

1. Loosen 5mm bolts.
2. Unscrew main bolt.
3. Install saddle rails into the rocker in the middle position.
4. Find desired setback.
5. Tighten the 5mm bolt up at 6Nm.
6. Adjust seat horizontally.
7. Tighten the 6mm bolt up at 12Nm.

If you are unable to find the desired setback, push the saddle up to the distance recommended by the manufacturer.



### **1: 3D pressfit headset creaking:**

Because some parts have a tight tolerance, it might be necessary to put a slight amount of grease under the top cap.

### **2. Saddle rails:**

If your saddle rails are not round and made of metal, please refer to Ritchey's part numbers. These parts are not sold by Argon 18 but available on Ritchey's website ([ritcheylogic.com](http://ritcheylogic.com)).

### **3. Tire compatibility:**

Compatibilities of standard tires with this bikes: 700x 28c (30mm) – Any tire/rim combination compatible.

### **4. Hydraulic brake instructions:**

For installation, adjustment and maintenance of the **HD-T910 TT Hydraulic brake** system, see the manufacturer's instructions at the link below.  
[https://trpcycling.com/wp-content/uploads/2018/03/HD\\_910-Hydro-TT-FM-Owners-Manual-22mar2018.pdf](https://trpcycling.com/wp-content/uploads/2018/03/HD_910-Hydro-TT-FM-Owners-Manual-22mar2018.pdf)

Please contact customer service for any further inquiries.

# 18. Min/Max Seat Post Insertion

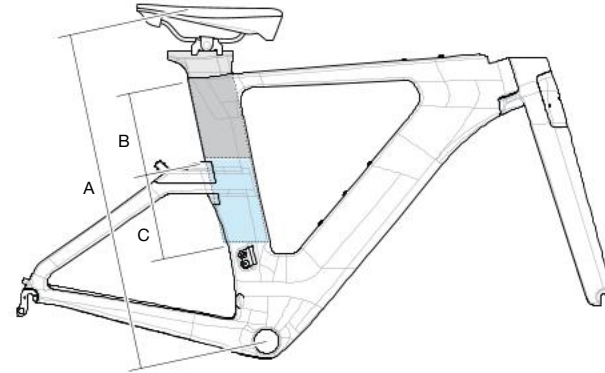
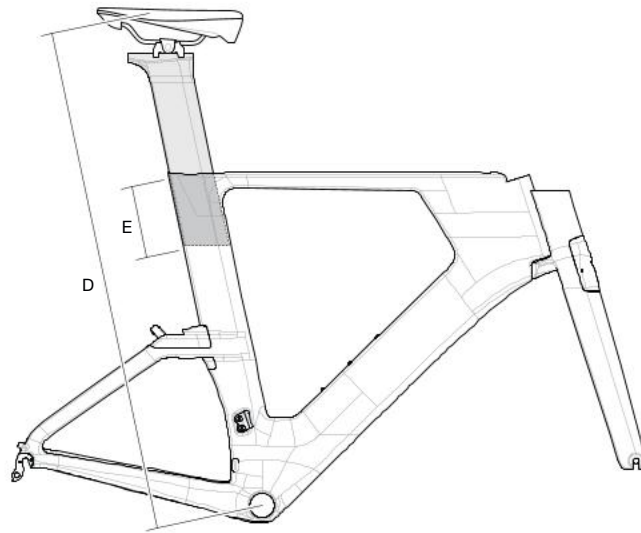

NOTE: THE ABOVE IMAGE IS FOR VISUAL REFERENCE OF SEATPOST INSERTION ONLY

Refer to the supplied tables for details on Saddle Height and SeatPost insertion limits.

- i. The correct frame size must be determined according to the saddle height limits.
  - A. Minimum Saddle Height
  - D. Maximum Saddle Height

- ii. Depending on the size of the frame and the desired saddle height, the SeatPost might need to be cut.

- B. Maximal insertion depth in the Frame's SeatTube.
- C. Required SeatPost cut length to be able to adjust the Saddle Height at the Minimum position.
  - Adjust the SeatPost cut length in accordance with your desired Saddle Height.

**Required minimum SeatPost Cut length = C - ("desired Saddle Height" - A)**

- Example: - For a desired Saddle Height of 600mm on a XS-E 117 Disc Frame
- The required minimum SeatPost Cut length is: 105 - (600-586) = 91mm
- E. Minimal insertion depth in the Frame's SeatTube.

Saddle Height Limits		E-117 TRI DISC			
Size	Saddle H Min	ST Max Insert	SP Cut	Saddle H Max	SP Min Insert
	mm	mm	mm	mm	mm
	A	B	C	D	E
X-Small	586	170	105	781	80
Small	625	210	65	820	80
Medium	641	225	50	836	80
Large	671	255	20	866	80
X-Large	698	275	0	893	80