

ARGON 18



E-119 TRI+
DISC

TRAVEL GUIDE

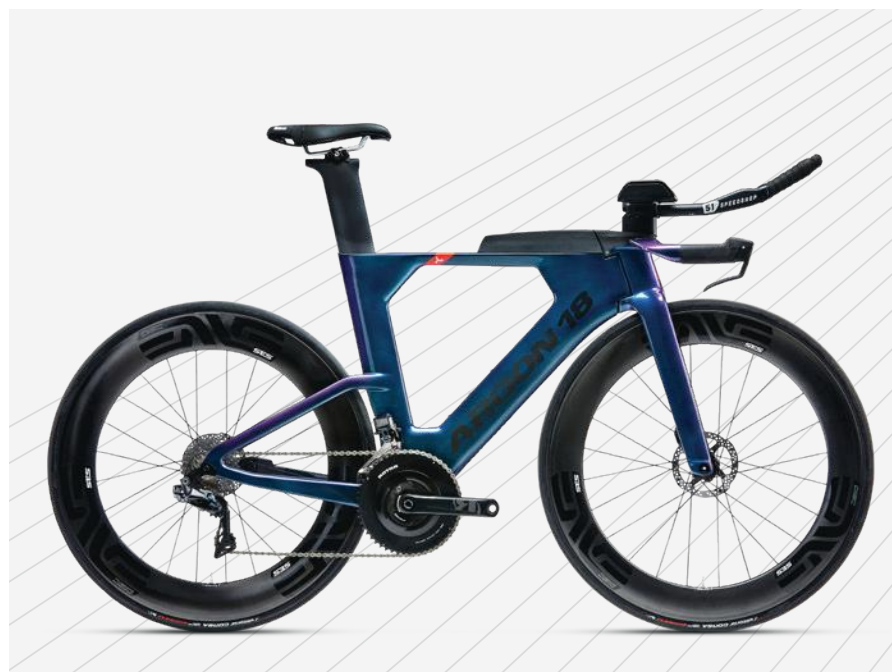



TABLE OF CONTENTS

TOOLS NEEDED & EMERGENCY REPAIR KIT	3
DISASSEMBLY AND PACKING	3-7
1. REMOVE THE WHEELS	3
2. REMOVE THE SEATPOST COLLAR AND SEATPOST	4
3. REMOVE THE BENTO BOX	4
4. REMOVE THE STEM CAP	5
5. REMOVE THE BOTTLE CAGE MOUNT	5
6. LOOSEN THE BRIDGE	6
7. REMOVE THE BRIDGE	6
8. REMOVE THE HANDLEBAR	7
9. PACK YOUR BIKE	7
REASSEMBLY	8-11
10. INSTALL THE HANDLEBARS	8
11. INSTALL THE BRIDGE	8
12. TIGHTEN THE BRIDGE	9
13. INSTALL THE BOTTLE CAGE MOUNT	9
14. INSTALL THE STEM CAP	10
15. INSTALL THE BENTO BOX	10
16. INSTALL THE WHEELS	11
17. INSERT THE SEATPOST AND SEATPOST COLLAR	11
CONTACT	12

MY E-119 TRI+ DISC

Size: _____

Serial number: _____

Seatpost height: _____

Bridge angle: _____

TOOLS NEEDED & EMERGENCY REPAIR KIT

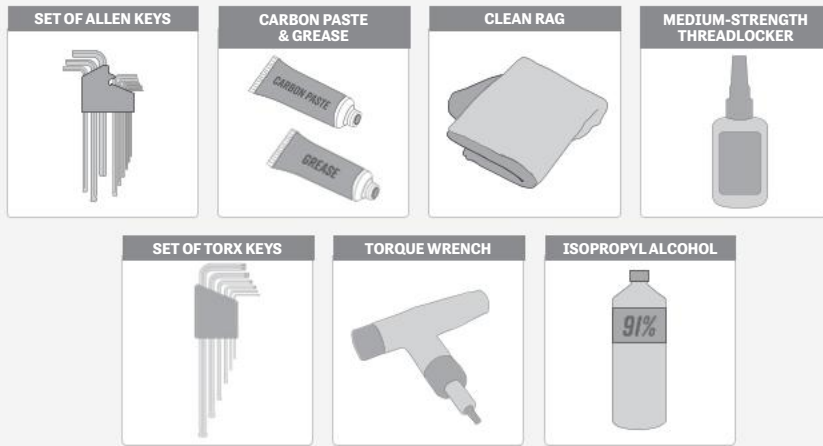

IMPORTANT:

EMERGENCY REPAIR KIT. Essential parts to always have on hand IN CASE OF EMERGENCY...THIS MIGHT SAVE YOUR RIDE!

SEAT POST CLAMP



81504

SPARE REAR DERAILLEUR HANGER



80802

80832

SPARE BRAKE PAD



Tektro F10RS Semi-Metallic



IMPORTANT:

Indicates special precautions and important steps that must be taken to avoid damage and/or injury.

5.5 Nm

4

Torque Value
Allen key size



Apply **carbon paste** on the indicated surfaces.



Apply **threadlocker** on the indicated surfaces.



Apply **grease** on the indicated surfaces.

1. REMOVE THE WHEELS

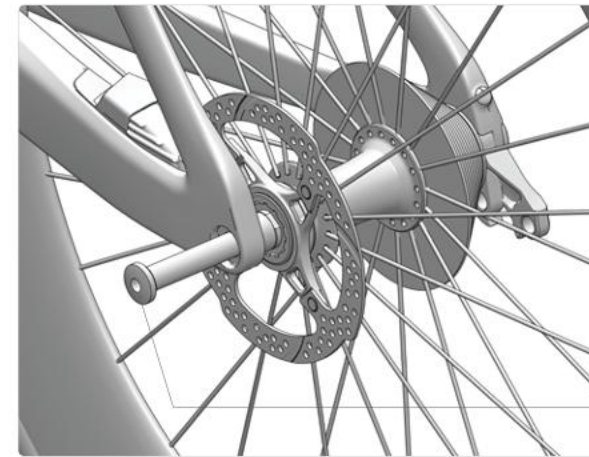

1. Remove the front wheel using a 6mm allen key.
2. Repeat for rear wheel.
3. If the travel bag or case doesn't secure both axles, install an axle spacer to avoid frame compression.
4. Install brake pad spacer in both calipers to avoid brake pad locking closed during travel.
5. Depending on your travel case, the rear derailleur may also need to be removed.



Brake pad spacer

2. REMOVE THE SEATPOST COLLAR AND SEATPOST

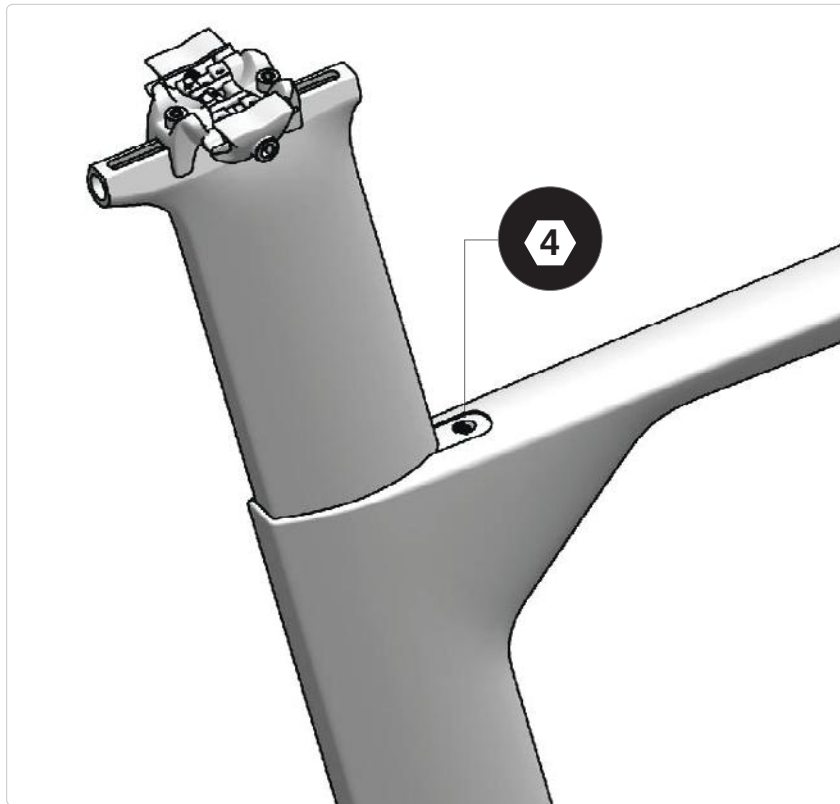

1. Mark or record the height of the seatpost.
2. Unscrew the M8 x 10mm set screw in place.
3. Remove the wedge by lifting with the Allen key before removing the seatpost.
4. Remove the seatpost.
5. Unplug the battery if using Di2.
6. Store the wedge and seatpost in your travel bag.

3. REMOVE THE BENTO BOX

1. Remove the rear M4 x 16mm screw.
2. Loosen both M4 x 16mm front screws.
3. Lift the rear of the bento box and slide it toward the rear of the bike to remove the unit.
4. Place the bento box and screws in the travel bag.

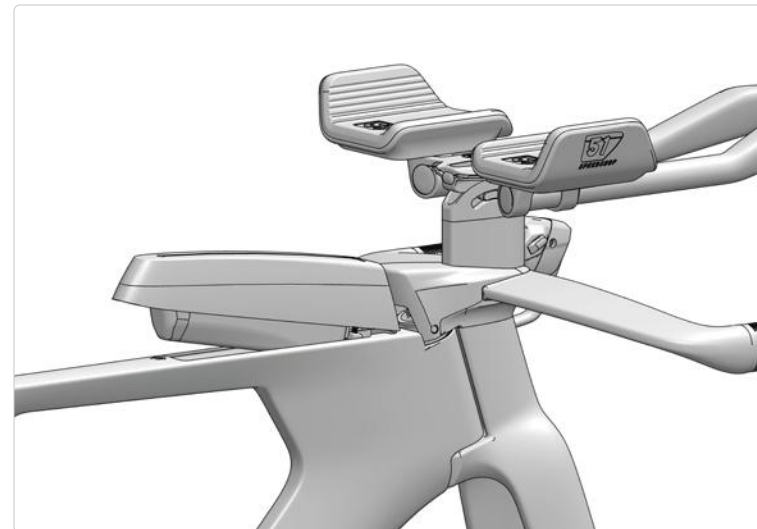
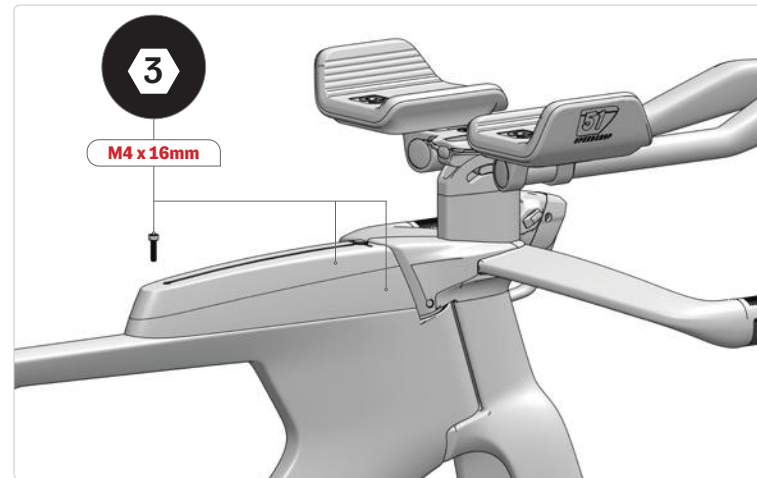

4. REMOVE THE STEM CAP

1. Remove both M3 x 6mm stem cap screws.
2. Lift the rear of the stem cap and pull backward until the front edges are clear of the first spacer.
3. Remove the cap and place the stem cap and screws in your travel bag.

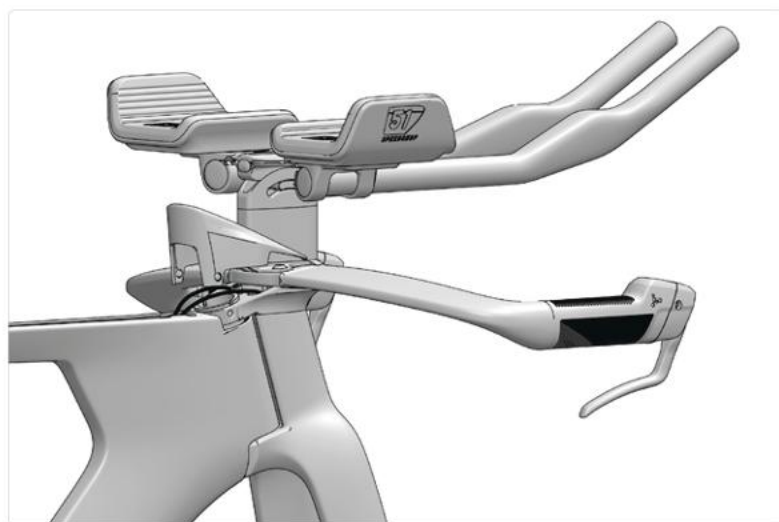
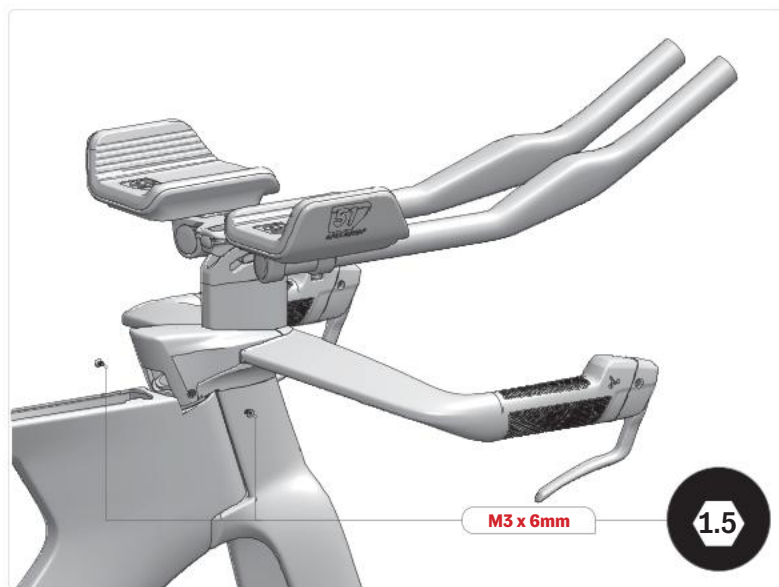

5. REMOVE THE BOTTLE CAGE MOUNT

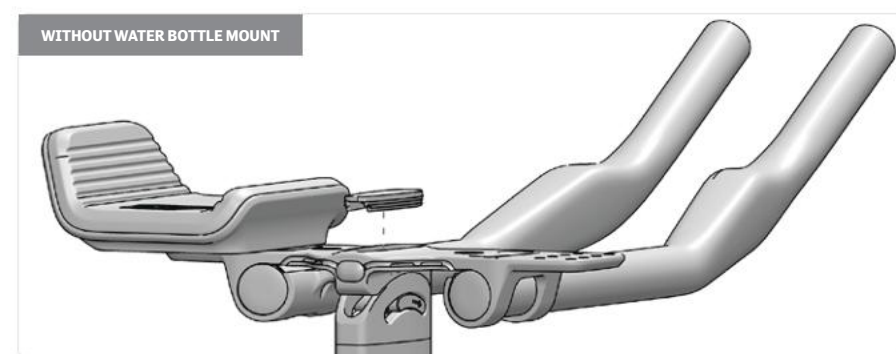
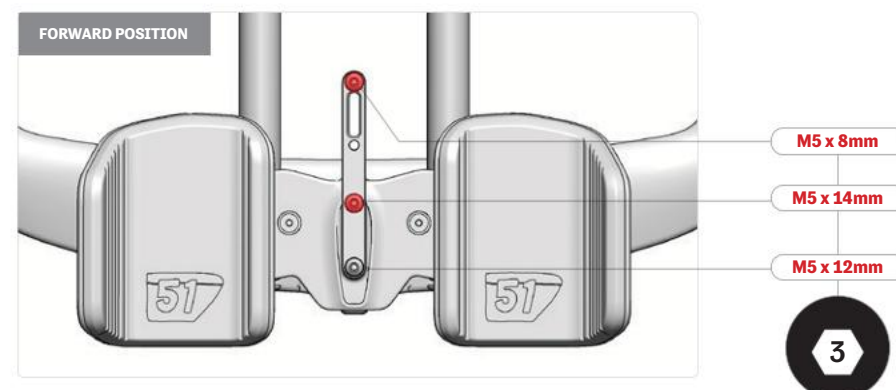
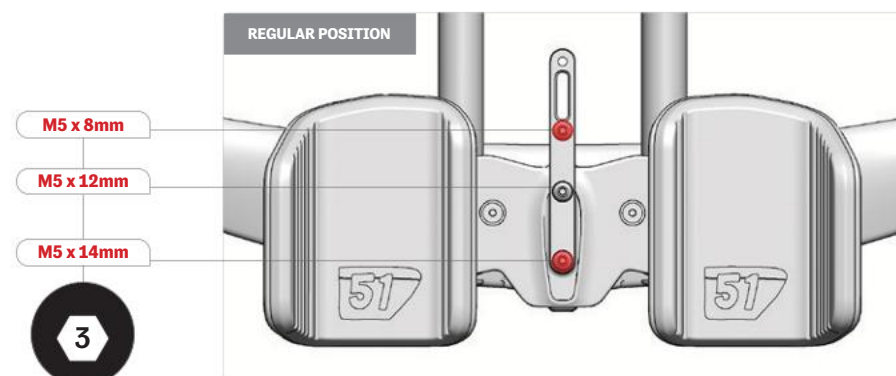

1. Unscrew the water bottle cage and the mount.
2. Remove the bridge plug if the mount is not being used.

6. LOOSEN THE BRIDGE

1. Record your bridge angle. _____. Angles are laser etched on the swivel spacer and beam.
2. Loosen the two M6 x 18mm swivel screws (only one turn) just to allow angle movement.
3. Unplug the shifter from the junction box or Blipbox, if you have an electronic build.

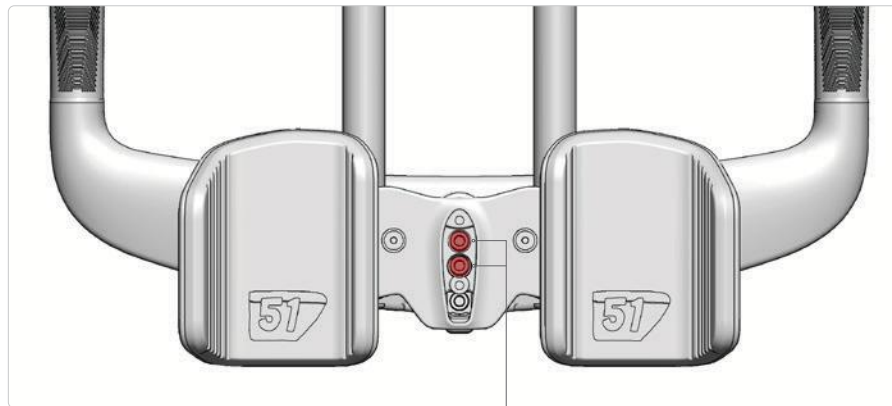

M6 x 18mm



7. REMOVE THE BRIDGE

1. Tilt the bridge backward to access the front spacer M6 screw.
2. Remove the front spacer screw.
3. Tilt the bridge forward to access the rear spacer M6 screw.
4. Remove the rear spacer screw.
5. Pack the bridge, spacers and screws in the travel bag.

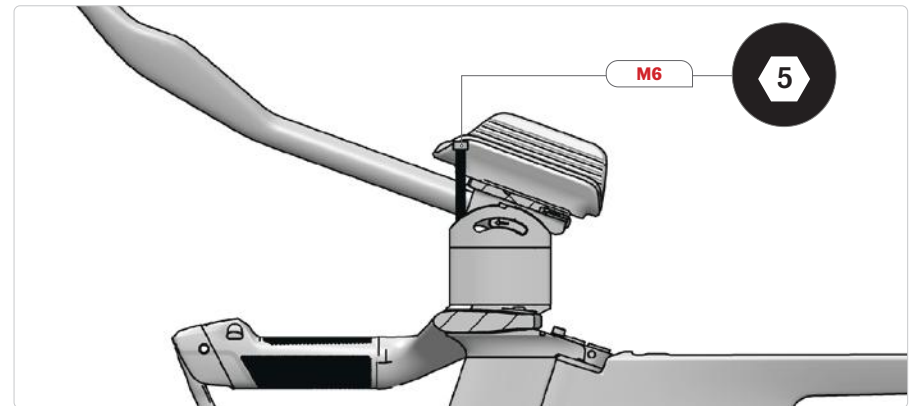

M6

5

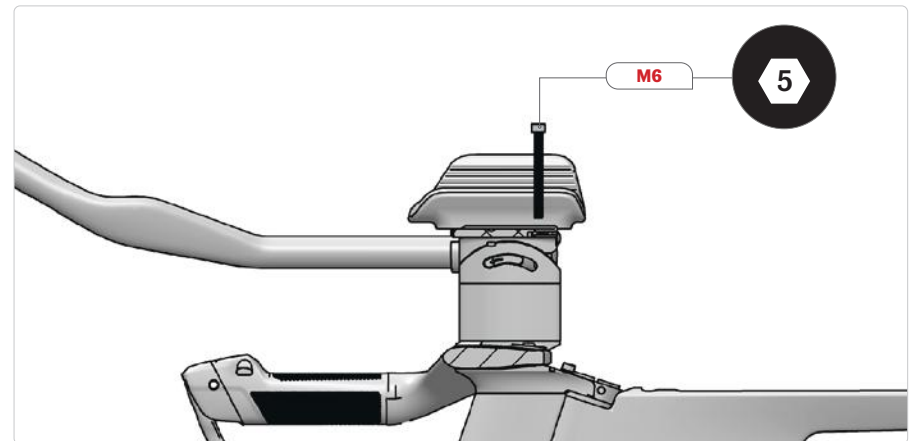

M6

5

8. REMOVE THE HANDLEBAR

1. Remove both M6 x 16mm screws from the first spacer.
2. Remove the first spacer.
3. Pack the first spacer and screws in the travel bag.

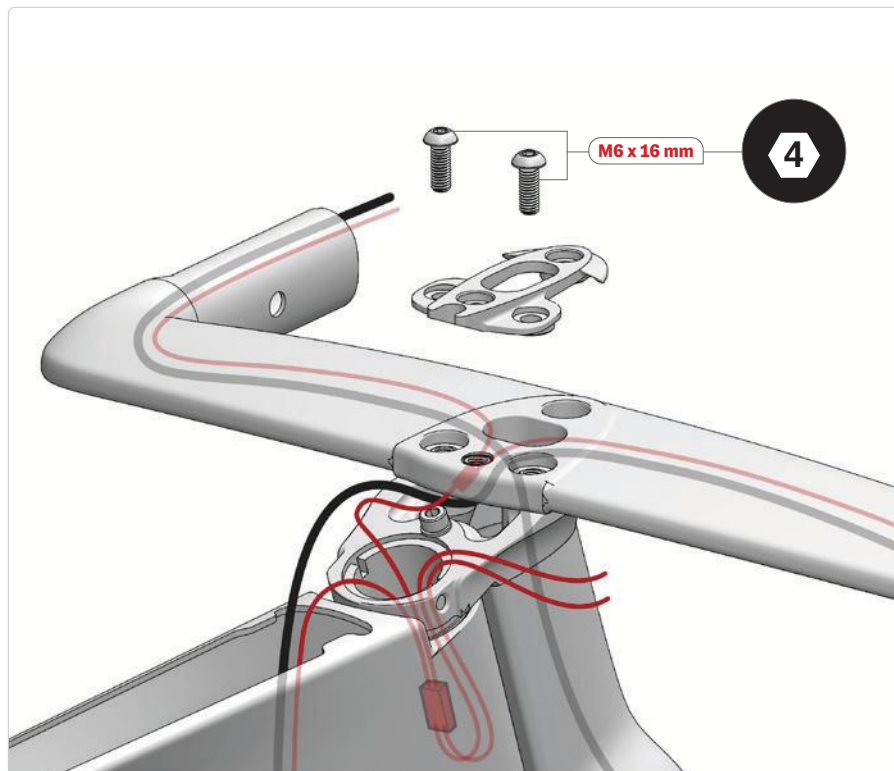

9. PACK YOUR BIKE

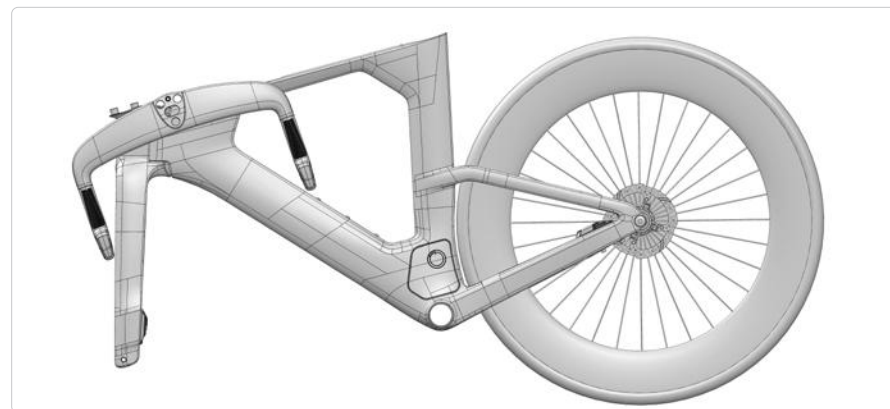

1. Place and secure the handlebar on the non-drive side of the frame.
2. Pack the bike, wheels and small parts in the travel bag according to bag instructions.
3. Make sure everything is secured (chain, handlebar, bridge assembly, etc.) to avoid paint damage.

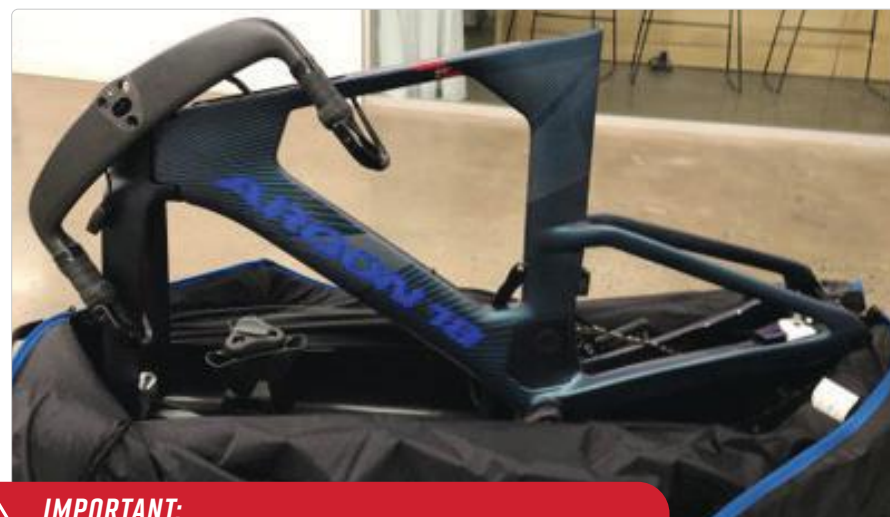

IMPORTANT:

Use a spacer in axles to avoid compression damage during travel.

10. INSTALL THE HANDLEBARS

1. Unpack the bike from the travel bag.
2. Install the handlebar on the fork.
3. Install the first spacer over the handlebar.
4. Apply grease to the threads of both M6 x 16mm button head screws (SKU: 81545).
5. Tighten both M6 x 16mm button head screws to 6 Nm.

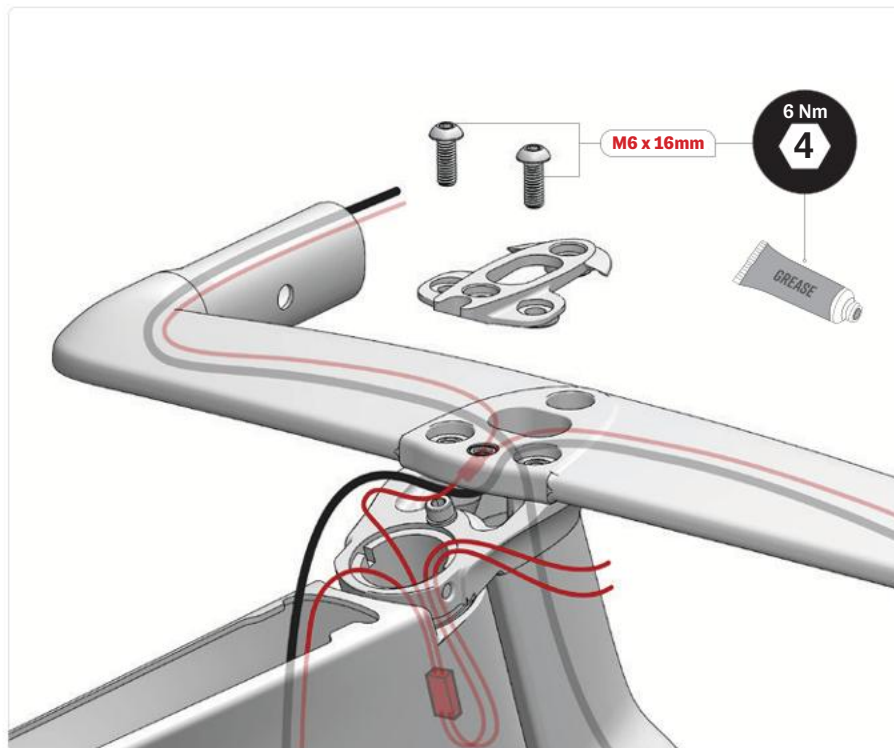

11. INSTALL THE BRIDGE

1. Apply grease to the threads of the two spacer screws (SKU: 81532 to 81541).
2. Tilt the bridge forward to install the rear spacer M6 screw.
3. Install and tighten the rear M6 spacer screw to 9 Nm.
4. Tilt the bridge backward to install the front spacer M6 screw.
5. Install and tighten the front M6 spacer screw to 9 Nm.
6. For electronic assembly, run the extension cable from the junction box through the channel in the spacers and swivel.
7. Connect both extensions cables to the JC-41 junction box or Blipbox if you have an electronic build.

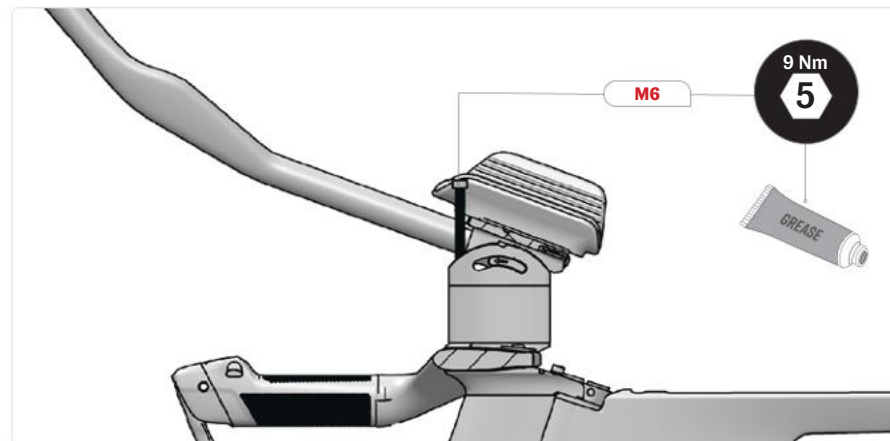
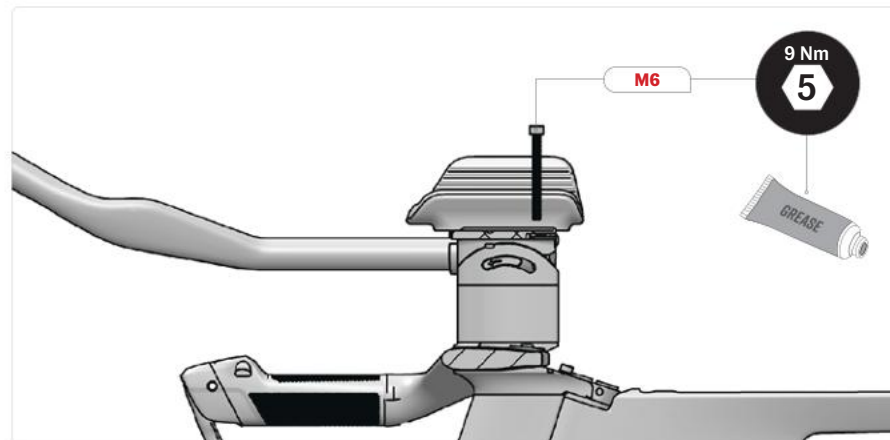

12. TIGHTEN THE BRIDGE

1. Adjust the bridge angle as noted while disassembling.
2. Tighten both M6 x 30mm screws to 9 Nm.

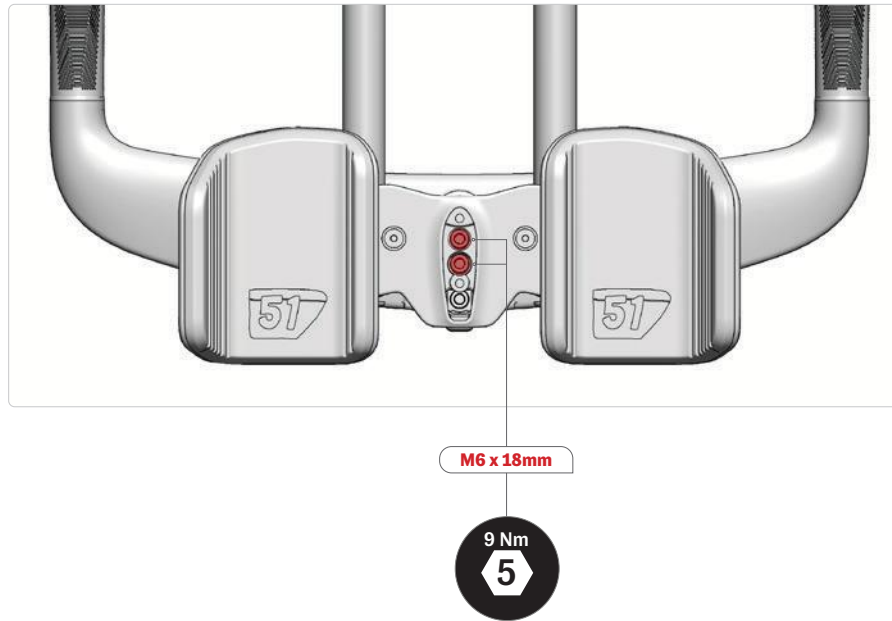

13. INSTALL THE BOTTLE CAGE MOUNT

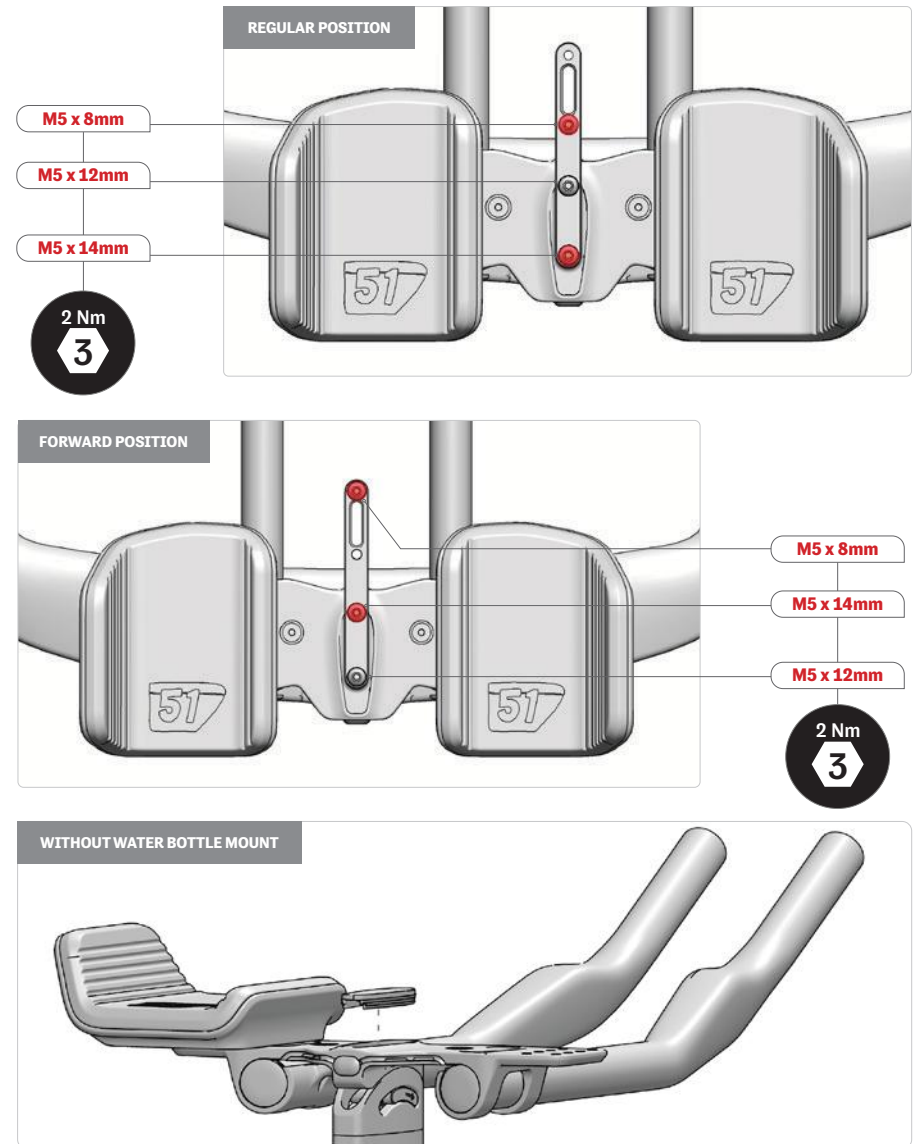

1. Install the water bottle mount on the bridge, using the grey M5 x 12mm screw. Tighten it to 2 Nm.
2. Screw the water bottle cage onto the mount at the desired position using the red screws. Tighten both screws to 2 Nm.
3. Insert the bridge plug if the mount is not being used.

14. INSTALL THE STEM CAP

1. Insert the front edges into the first spacer grooves.
2. Push the stem cap down until the holes are aligned with the threads on the fork.
3. Install and hand-tighten both M3 x 6mm screws.
4. If using eTap: Push the blipbox into the stem cap until it clicks.

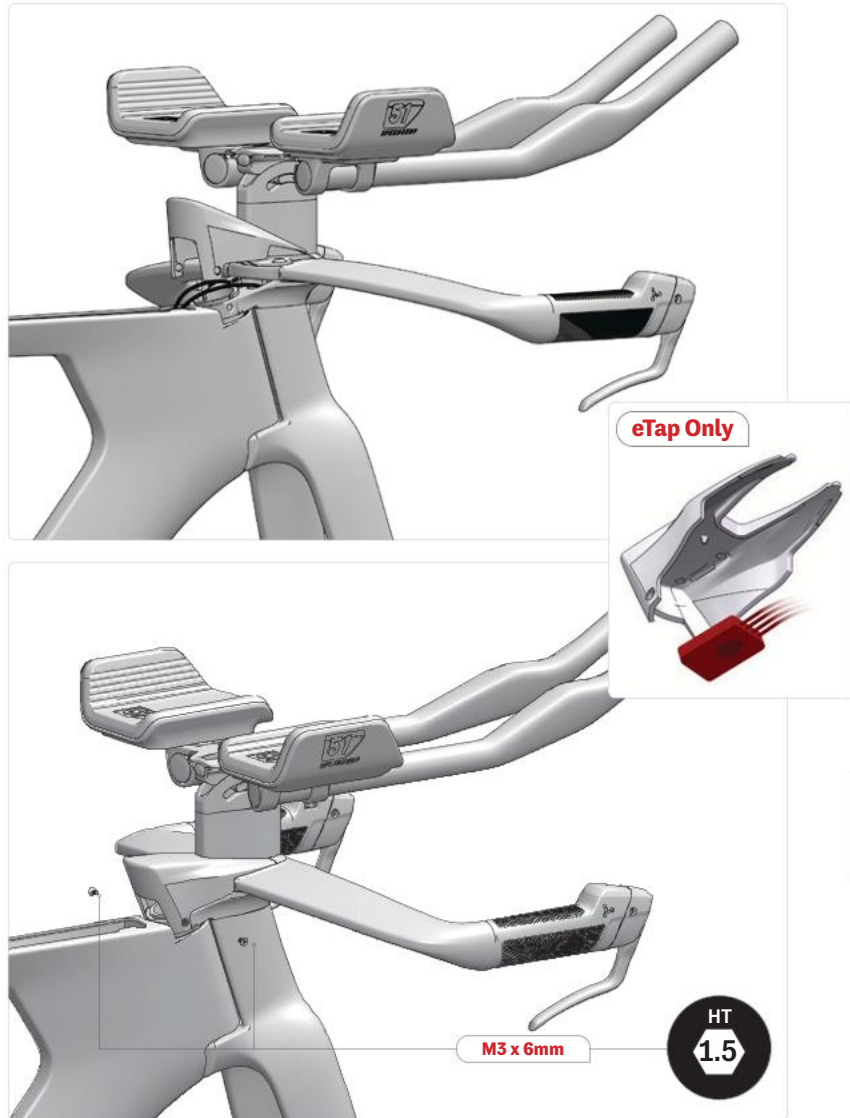

15. INSTALL THE BENTO BOX

1. Slide the bento box onto the frame hole on the top tube. Make sure the frame is between the bento box and the clamp.
2. Apply threadlocker to the threads of the screws.
3. Hand-tighten the three M4 x 16mm screws.

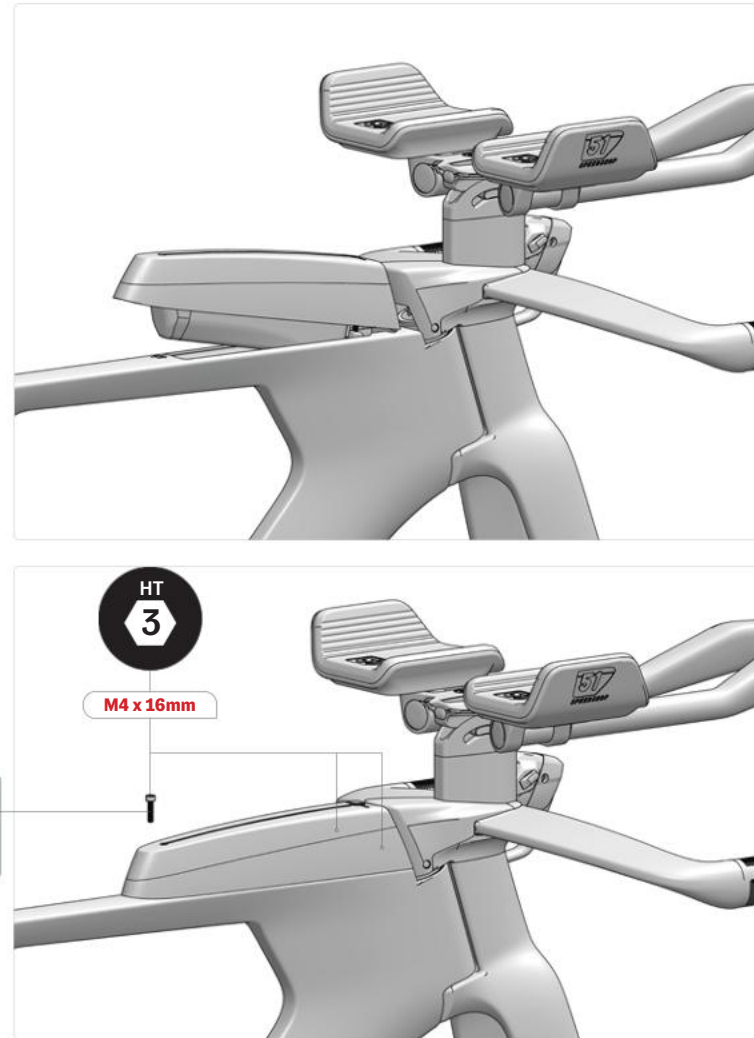

16. INSTALL THE WHEELS

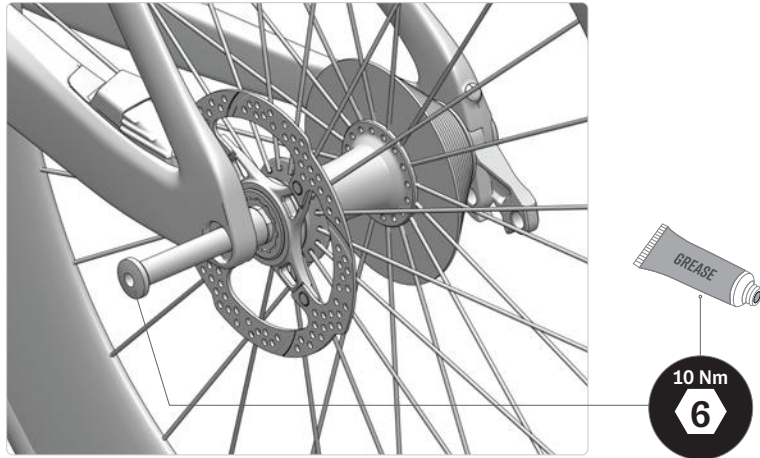

1. Remove both axle protectors.
2. Remove both brake pad spacers.
3. Apply grease to the axle threads.
4. Place the rear wheel in the frame.
5. Thread the thru-axle through the wheel and tighten it to 10 Nm.
6. Repeat for front wheel.
7. Apply pressure on both brake levers.
8. Make sure wheels are turning freely and the discs don't rub. If they do, adjust the caliper position.

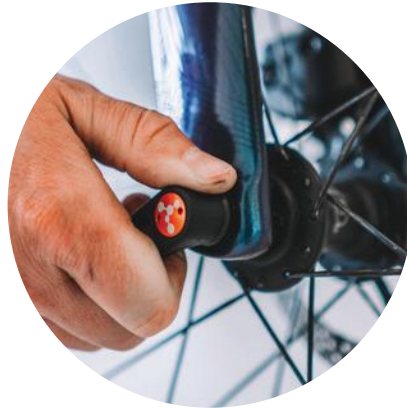

17. INSERT THE SEATPOST AND SEATPOST COLLAR

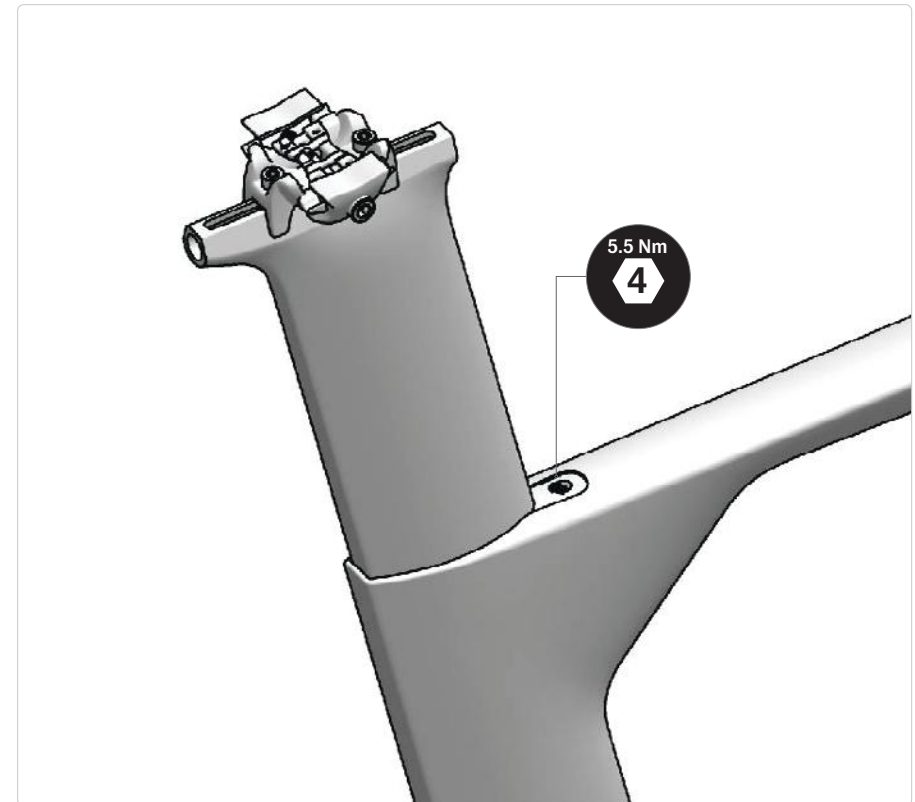

1. Plug in the Di2 battery if using a Di2 build.
2. Set the seatpost to the desired height (where you marked your height while disassembling).
3. Tighten the M8 x 10mm set screw on the seat post clamp to 5.5 Nm.



IMPORTANT:

Refer to p.16 of the assembly guide for seat post **MIN** and **MAX** insertion values.



argon18.com