

VALID FOR MY2025 VERSION 1.0 / 2024-07-29- EQUATION 375A-B

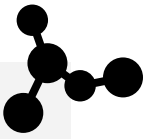

EQUATION

ARGON 18

VALID FOR MY2025 VERSION I.O / 2024-07-29- EQUATION 375A-B

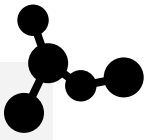

EQUATION

ARGON 18

TABLE OF CONTENTS

1. Tools Needed & Spare Parts Kit	4
2. Troubleshooting / Tips & Specifications	5
3. Frameset Inspection	6
4. Frameset Skus & Descriptions	7-8
5. Seat Post Installation	9
6. Seat Post Min. & Max. Insertion	10
7. Rear Derailleur Hanger Assembly	11
8. 3D Headset Installation	12
9. Cable and Housing Routing – Mechanical Shifting	13-16
10. Cable and Housing Routing – Mechanical 1X Shifting	17-19
11. Cable and Housing Routing – Electronic Wireless	20-22
12. Cable and Housing Routing – Electronic Wire	23-26
13. Fork Installation	27
14. Stem Installation	28
15. Chain Catcher Installation	29
16. Fender Installation	30
17. BB Cap and Plug Installation	31

To maintain the validity of the warranty, the bicycle must be fully assembled by an authorized Argon 18 dealer. High-end components, particularly carbon parts, require extra care during assembly.

These components must be installed using a torque wrench to ensure each bolt is at the specified torque setting to prevent damage.



MY EQUATION

Date of Purchase: _____

Retailer: _____

Size: _____

Serial Number: _____

1. TOOLS NEEDED & SPARE PARTS KIT

1. Hydraulic Hose Cutter



2. Allen Key Set

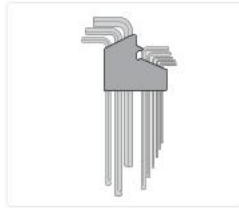

3. Flush cut plier



4. Carbon Paste & Grease



5. Utility Picks



6. Clean Rag



7. Derailleur Hanger Alignment Gauge

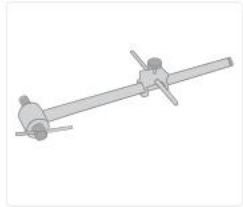

8. Cables and Housing Cutter



9. Thread Locker Medium strength



10. Isopropyl Alcohol



11. Torque Wrench



12. Headset Press



13. 8mm Wrench



14. Bleed Kit



15. Torx Key Set



16. Mineral Oil



SPARE PARTS KIT

1. Seatpost Clamp



80801

2. Spare Rear Derailleur Hanger



80802

80832
Available Separately



IMPORTANT:

Spare Parts Kit: Essential parts to always have on hand IN CASE OF EMERGENCY...

THIS MIGHT SAVE YOUR RIDE!

2. TROUBLESHOOTING / TIPS & SPECIFICATIONS

Brakes

Front brake - 140/160mm disc rotors

Rear brake - 140/160mm disc rotors

Rear mount thickness: 25mm.

Tire Clearance

Maximum clearance: 700x32c. Tires must be no wider than 34mm for both front and rear wheels.

Seat Post

Ø 27.2mm

Bottom Bracket

BB86 (Press-fit)

Headset

A18 3D IST2

Bottom Bearing: MR127 - 1 1/2", 36° x 45° Stainless Steel

Top Bearing: MR127 - 1 1/2", 36° x 45° Stainless Steel

*Some systems may require a 1 1/2", 45° x 45° top bearing

For more information, please refer to:

Argon 18 - Internal routing compatibility

Chainring

The Equation can run a 54-42 chainring maximum.

A chainring of 48T maximum can be installed in 1x configuration.

Seat Post Collar

Ø 31.8mm

Front Derailleur

The Equation is equipped with a non-removable front derailleur hanger.

Accessories

The Equation is designed to take fenders with 140mm rear disc rotor. The fenders reduced the tire clearance to 700x28c (30mm).

Please contact customer service at info@argon18.com for any further inquiries.

3. FRAMESET INSPECTION

Before assembling your new Equation, please verify that you have all the following:

1. Frameset parts checklist (see p.7-8).
2. Inspect the frame for cosmetic defects (scratches, bumps, cracks, paint defects, etc.).
3. For reference, record serial number on p.3.

4. All the necessary bolts (refer to frameset parts, p.7-8).
5. For optimal shifting performance, use a derailleur alignment gauge to make sure that the derailleur hanger is straight.



Some of the following parts are already assembled on the frame. When assembling the bike, you will need to adjust these parts according to their torque specifications and fastener conditions when necessary.

No.	A18 SKU#	Function	Description	Screw Type	Torque	Detail	Qty
1	81052	Front Thru Axle	M12 x 1.5 x 119mm Axle	Thru Axle	12 Nm	Grease	1
2	81053	Rear Thru Axle	M12 x 1.5 x 161mm Axle	Thru Axle	12 Nm	Grease	1
3	80802*	Rear Derailleur Hanger Screw	M4 x 12mm Screw	Flat Head	2 Nm	Threadlocker	1
4	80801*	Seatpost Collar Screw	M5 x 22mm Screw	Socket Head	4 Nm	Grease	1
5	81195	Water Bottle Screw	M5 x 20mm Screw	Button Head	3 Nm	Grease	4
6	80806*	Chain Catcher Screw	M5 x 25mm Screw	Socket Head	3 Nm	Threadlocker	1

* Included with



Torque Value
Allen key size



Apply **carbon paste** on the indicated surfaces.



Apply **threadlocker** on the indicated surfaces.



Apply **grease** on the indicated surfaces.



IMPORTANT:

Indicates special precautions and important steps that must be taken to avoid damage and/or injury.

Torque value:
Under-torquing may cause parts to slip and cause injury.
Over-torquing may cause screw to break and/or part to slip and cause injury.

4. FRAMESET SKUS AND DESCRIPTIONS



Equation Frame
*Not available as a separate SKU

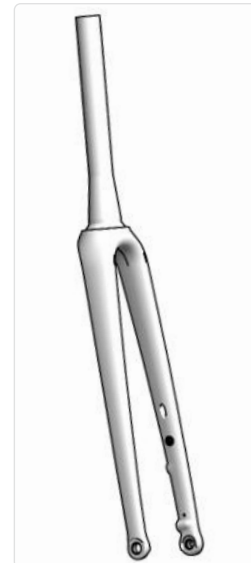

FK.EQU.M-XL.375A
FK.EQU.M-XL.375B
FK.EQU.XXS-S.375A
FK.EQU.XXS-S.375B



80808



80806



201107 (375A)
201108 (375B)



81278



81242



200845

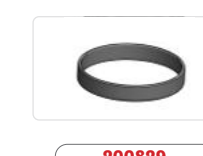

200829

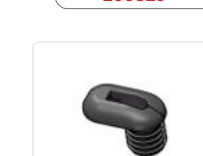

200758

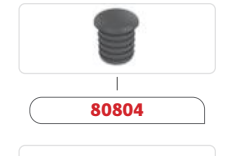

80804



80805



80985



201148



80801



80811



81195



80264



80802



201105 (375A)
201106 (375B)



81053



81052



81054

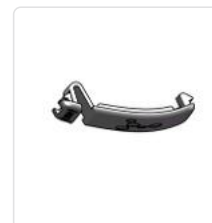

80548

Available Separately



80832



200725

Except for the frame itself, which is not sold separately as a spare part, all parts can be ordered by referring to their respective SKU number.

4. FRAMESET SKUS AND DESCRIPTIONS

NO.	NAME	A18 SKU#	QTY
1	Equation Frame	-	1
2	Fork Equation 47 mm (M-XL) -OR- Fork Equation 47 mm 52 mm (XXS-S)	FK.EQU.M-XL.375A FK.EQU.M-XL.375B FK.EQU.XXS-S.375A FK.EQU.XXS-S.375B	1
3	Rear Der. hanger TA Type A (incl. screw)	80802	1
4	Chain Suck Guard - Krypton CS/GF/Pro	81278	1
5	Long plug grommet	80804	3
6	Long grommet Di2	80805	1
7	Angled Grommet Di2	200758	1
8	Long grommet mechanical	80985	2
9	Rear Brake Oblong Cable Guide Flush	201148	1
10	FD Cable Stopper	81242	1
11	IST2 SRS Custom Cap	201105 (375A) 201106 (375B)	1
12	IST2 25mm Cap	201107 (375A) 201108 (375B)	1
13	IST2 25mm Column	200845	1
14	IST2 Sleeve	200829	1
15	Button Head Cap Screw For Water Bottle M5x20mm	81195	4
16	Chain Catcher (Incl. Small/Large, Washer and Screw)	80806	1
17	GW Front Thru Axle 12mm	81052	1
18	GW Rear Thru Axle 12mm	81053	1
19	Removable Lever For GW Thru Axle 12mm	81054	1
20	Plastic Plug For Water bottle Eyelet	80264	8
21	Foam Liner For Hydraulic Hose	80811	3
22	BB Cover - Electronic	80548	1
23	Seatpost Collar	80801	1
24	Fender Bracket	80808	1 Set
OPTIONAL PARTS THAT CAN BE ORDERED SEPARATELY			
-	Di2 battery holder (BT-DN300) for 27.2mm SP	200725	1
-	Rear derailleur hanger, Direct mount TA Type A	80832	1

5. SEATPOST INSTALLATION

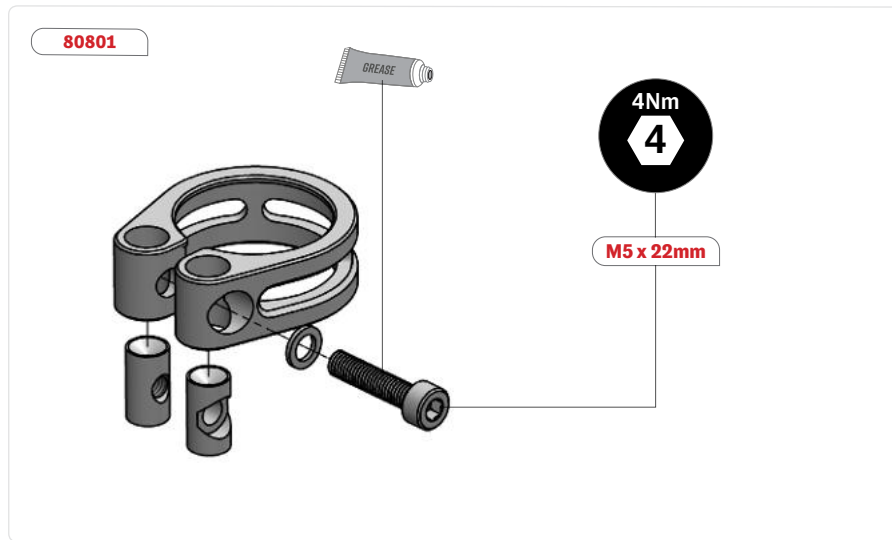

1. Apply grease on the thread of the M5 x 22mm socket head screw.
2. Assemble the seat post collar (80801) as shown.
3. Adjust the seatpost at the desired height. Make sure to follow the seatpost min and max insertion limits. (p. 10)
4. Tighten the M5 x 22mm socket head screw on the seatpost clamp to 4Nm.



IMPORTANT:

Refer to p.10 for seatpost
MIN and **MAX** insertion limits.

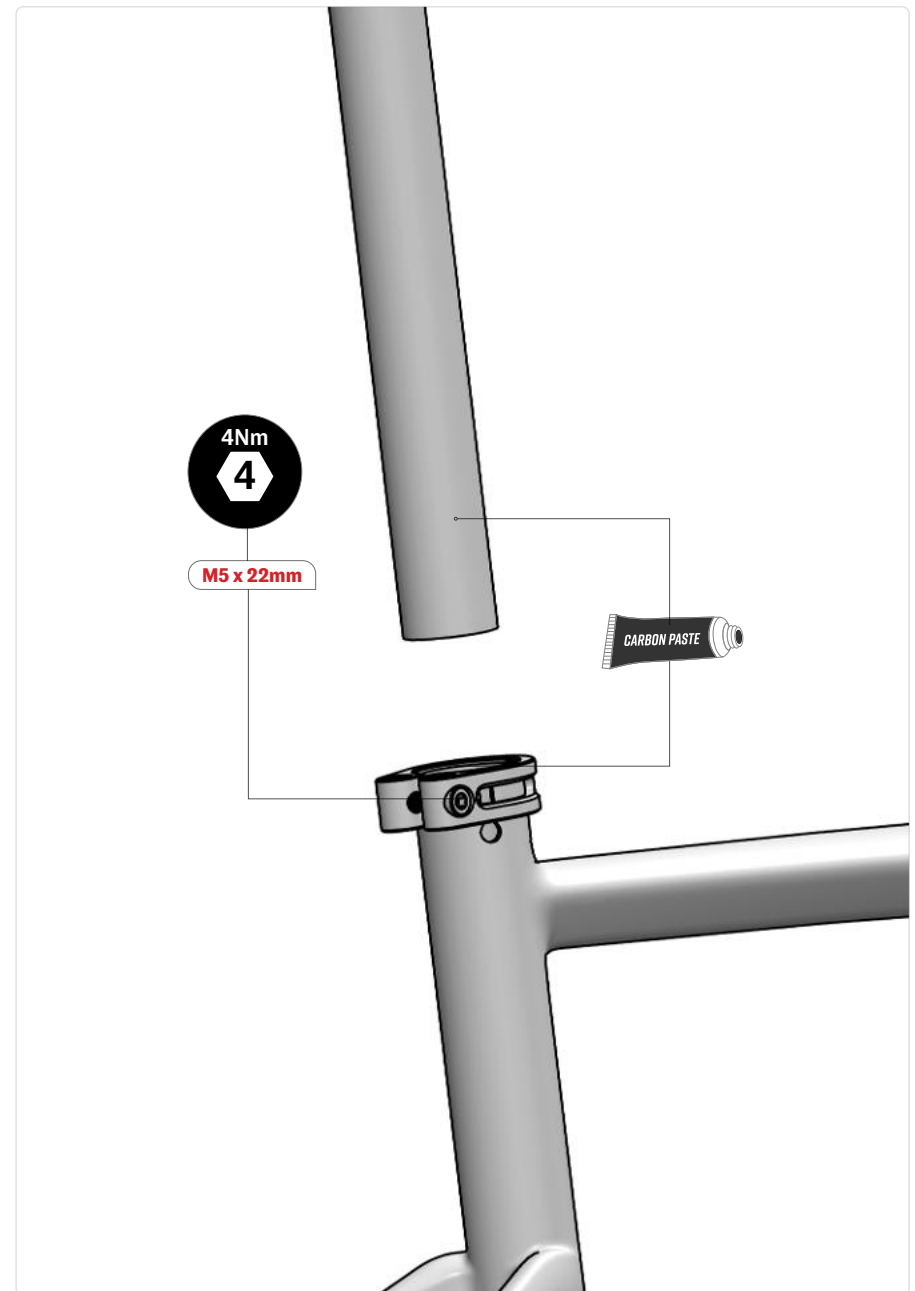

6. SEATPOST MIN. & MAX. INSERTION

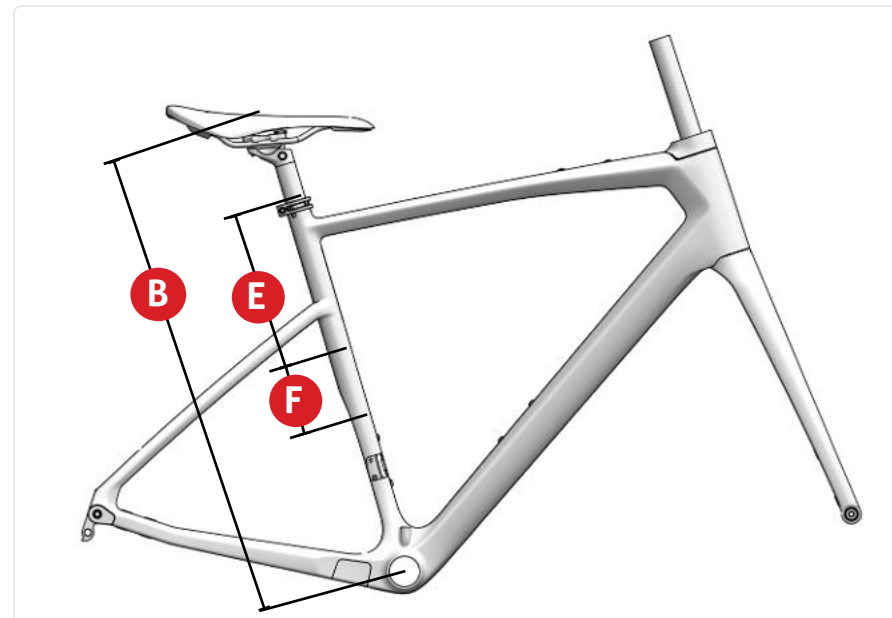

Refer to the adjacent table for details on saddle height and seatpost insertion limits:

i. The correct frame size must be determined according to the saddle height limits.

- A. Maximum Saddle Height.
- B. Minimum Saddle Height.

ii. Depending on the size of the frame and the desired saddle height, the seatpost might need to be cut.

If the desired saddle height is lower than value “C”, Calculate the required cutting length “G” as follow:

$$G = C - \text{“Desired saddle height”} + 10\text{mm (to allow adjustment)}$$

Example: For a desired saddle height of 635mm on a XX-Small frame, the required minimum seatpost cut length (G) is:

$$G = 650 - 635 + 10 = 25 \text{ mm}$$

Important: In any case the saddle height can be lower than value “B”.

SADDLE HEIGHT LIMITS (MM)

SIZE	Max Saddle Height	Min Saddle Height	Min Saddle Height (Without cut)	Min Seatpost Insert	Max Seattube Insert	Max Needed Seattube Cut
	A	B	C	D	E	F
XX-SMALL	740	520	650	80	170	130
X-SMALL	770	550	650	80	200	100
SMALL	805	585	650	80	235	65
MEDIUM	840	620	660	80	260	40
LARGE	875	655	655	80	300	0
X-LARGE	910	690	675	80	315	0

Based on saddle with 50mm between center of rail to top.



Minimum Seatpost Insertion: 80mm

Maximum Seatpost Cut: See seatpost manufacturer recommendation

7. REAR DERAILLEUR HANGER ASSEMBLY

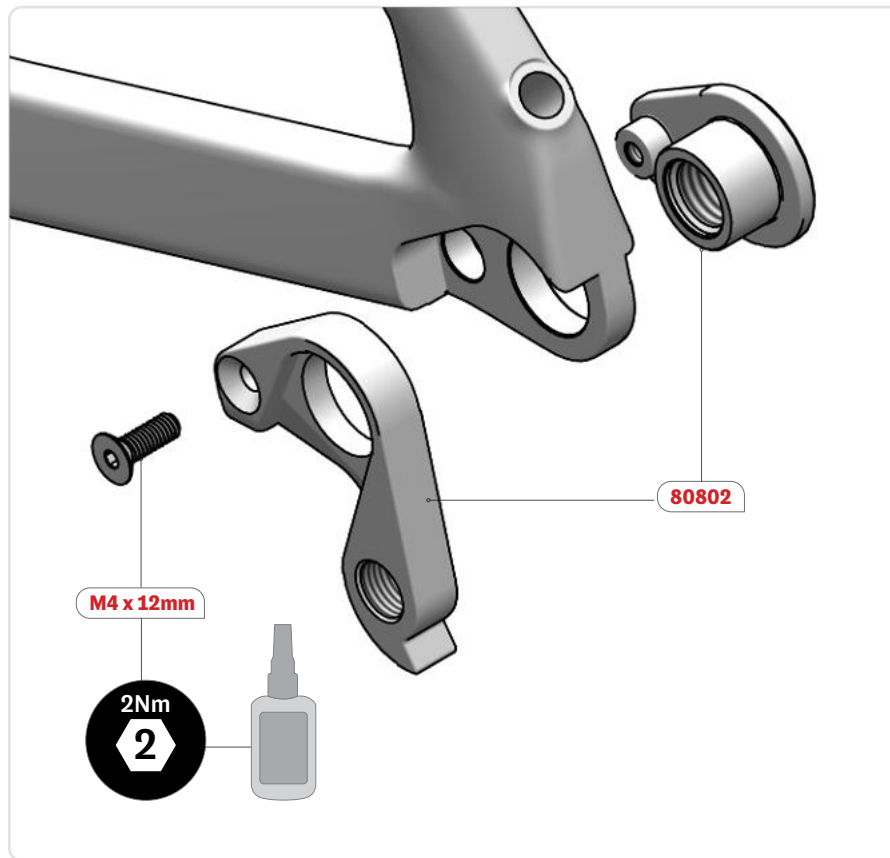

Assembling with a regular hanger:

1. Assemble the rear derailleur hanger (SKU: 80802) on the frame with the flat head cap screw M4 x 12 mm.
2. Apply a drop of blue threadlocker (no. 242) to the M4 x 12 mm screw threads and tighten to 2 Nm.
3. Use a rear derailleur hanger alignment gauge to align the rear derailleur hanger.

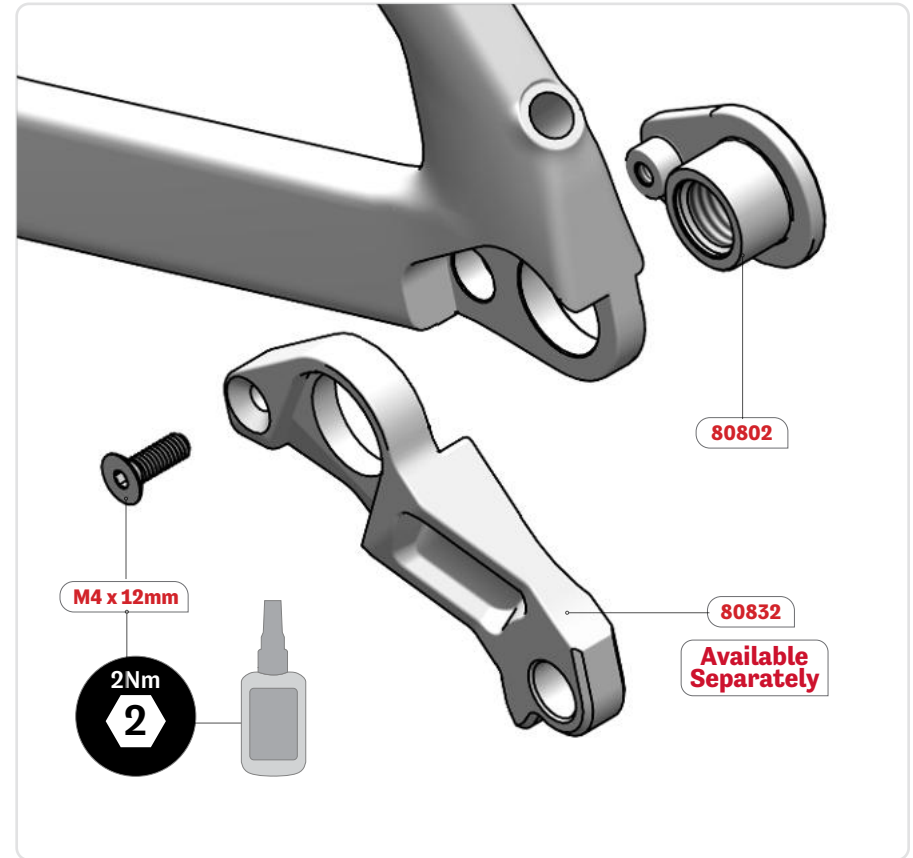

Assembling with a direct mount hanger:

1. Assemble the rear derailleur hanger (SKU: 80832), available separately, on the frame with the flat head cap screw M4 x 12 mm (included in SKU: 80802).
2. Apply a drop of blue threadlocker (no. 242) to the M4 x 12 mm screw threads and tighten to 2 Nm.
3. Use a rear derailleur hanger alignment gauge to align the rear derailleur hanger.

For assistance, visit Park Tool's website at:

<https://www.parktool.com/blog/repair-help/rear-derailleur-hanger-alignment>

8. 3D HEADSET INSTALLATION

AS WITH ALMOST ALL ARGON 18 BIKES, THE EQUATION PROVIDES YOU WITH THE BENEFIT OF THE 3D SYSTEM. THIS SYSTEM ALLOWS FOR 2 POSITIONS: 0MM AND 25MM.

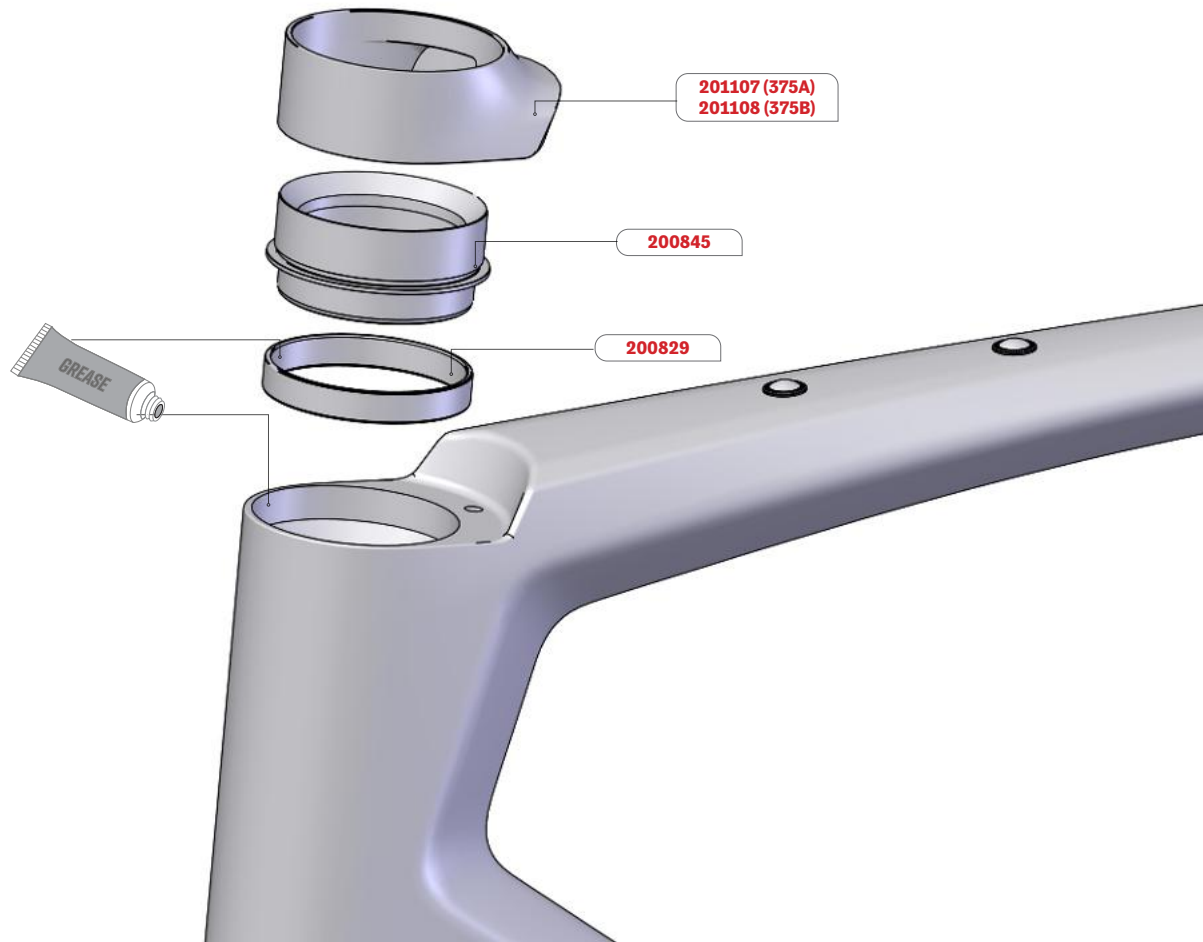

If the 25mm 3D headset is desired, follow the step below, if no 3D headset is desired, no action are required:

- 1.** Install the 3D headset plastic sleeve (SKU: 200829) into the top of the head tube. (Apply grease on the sleeve)
- 2.** Insert the 25mm headset column (SKU: 200845). (Apply grease on the column)
- 3.** Press the assembly using a headset press.
- 4.** Push the 25mm Cap on the column while aligning the pin in the frame hole.

9.1 CABLE AND HOUSING ROUTING - MECHANICAL SHIFTING

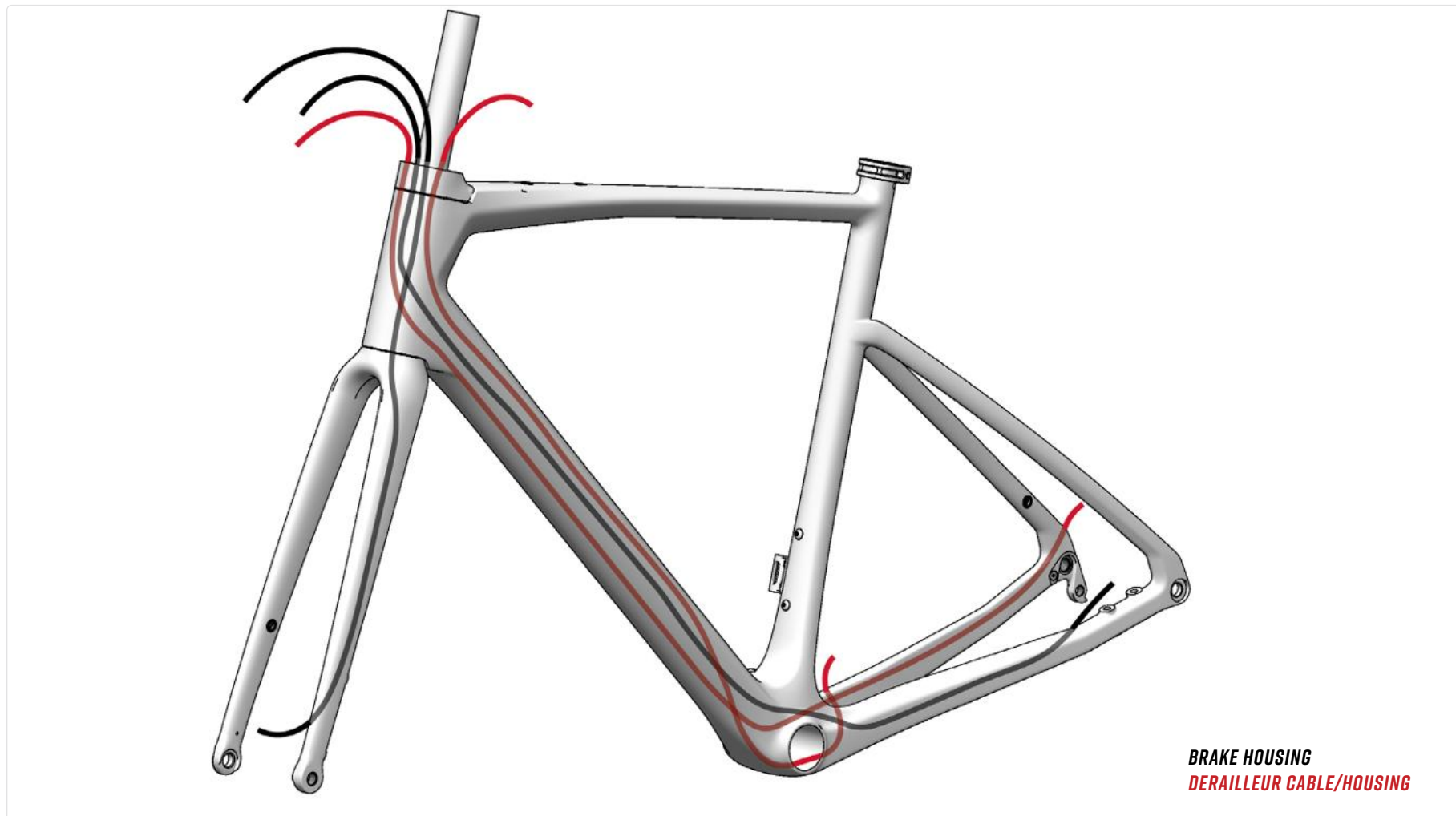

1. The rear brake and rear derailleur housing will run above the BB once installed.
2. The front derailleur housing will be under the BB once installed.
3. All housing can be covered by a foam liner (SKU: 80811).
4. Refer to the [Internal Routing Guide](#) on the website for the cable side around the steer tube, this depends on the choice of cockpit.

9.2 CABLE AND HOUSING ROUTING - MECHANICAL SHIFTING

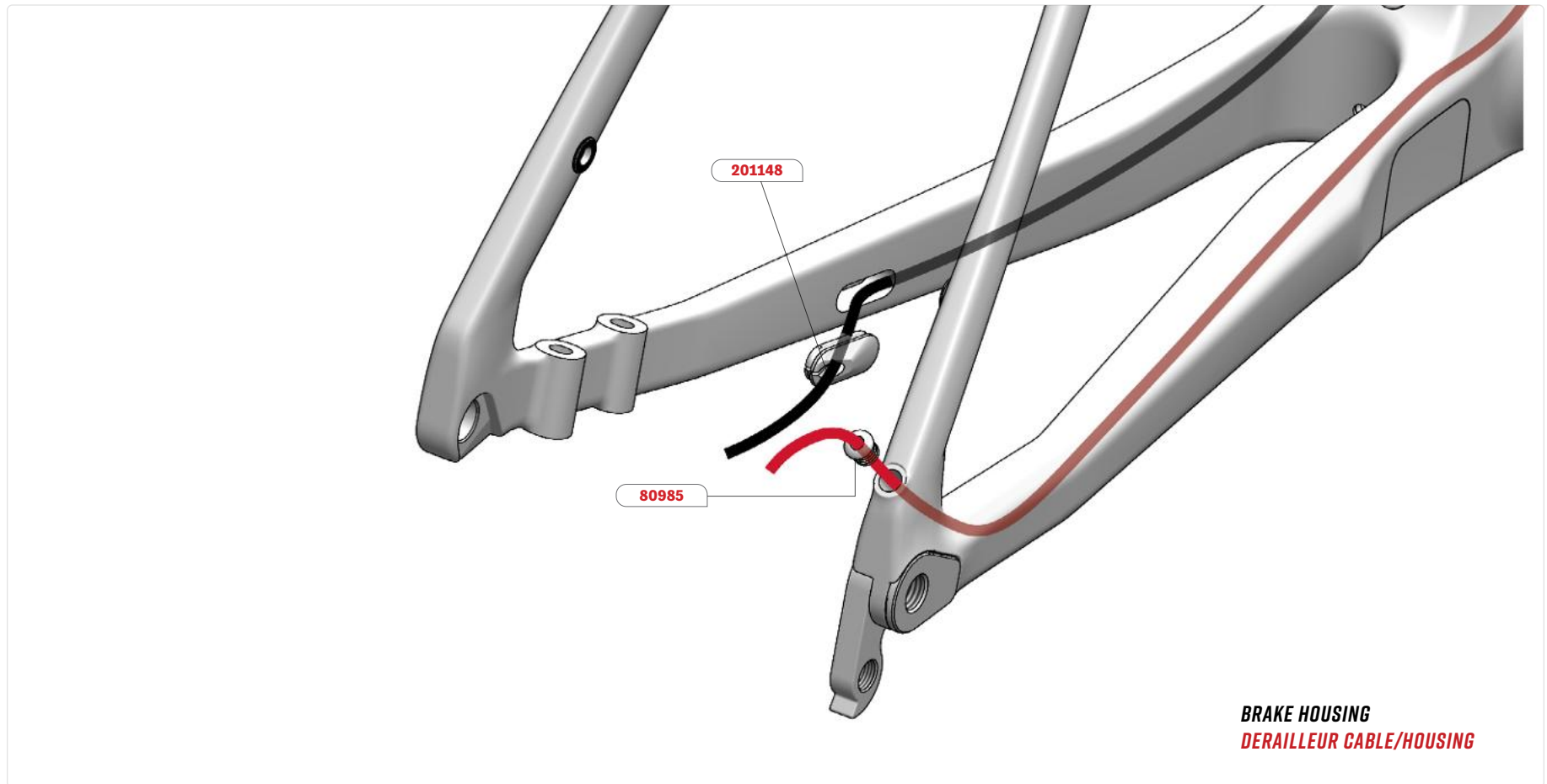

Rear Derailleur:

- 1.** Insert housing from rear hole on the seat stay.
- 2.** Guide the housing over the bottom bracket.
- 3.** Exit the housing through the headtube.
- 4.** Insert the mechanical grommet (SKU: 80985) into the seat stay hole.

Rear Brake:

- 1.** Insert housing from rear hole on the chainstay.
- 2.** Guide the housing over the bottom bracket.
- 3.** Exit the housing through the headtube.
- 4.** Insert the rear brake oblong flat cable guide (SKU: 201148) into the chainstay hole.

9.3 CABLE AND HOUSING ROUTING - MECHANICAL SHIFTING

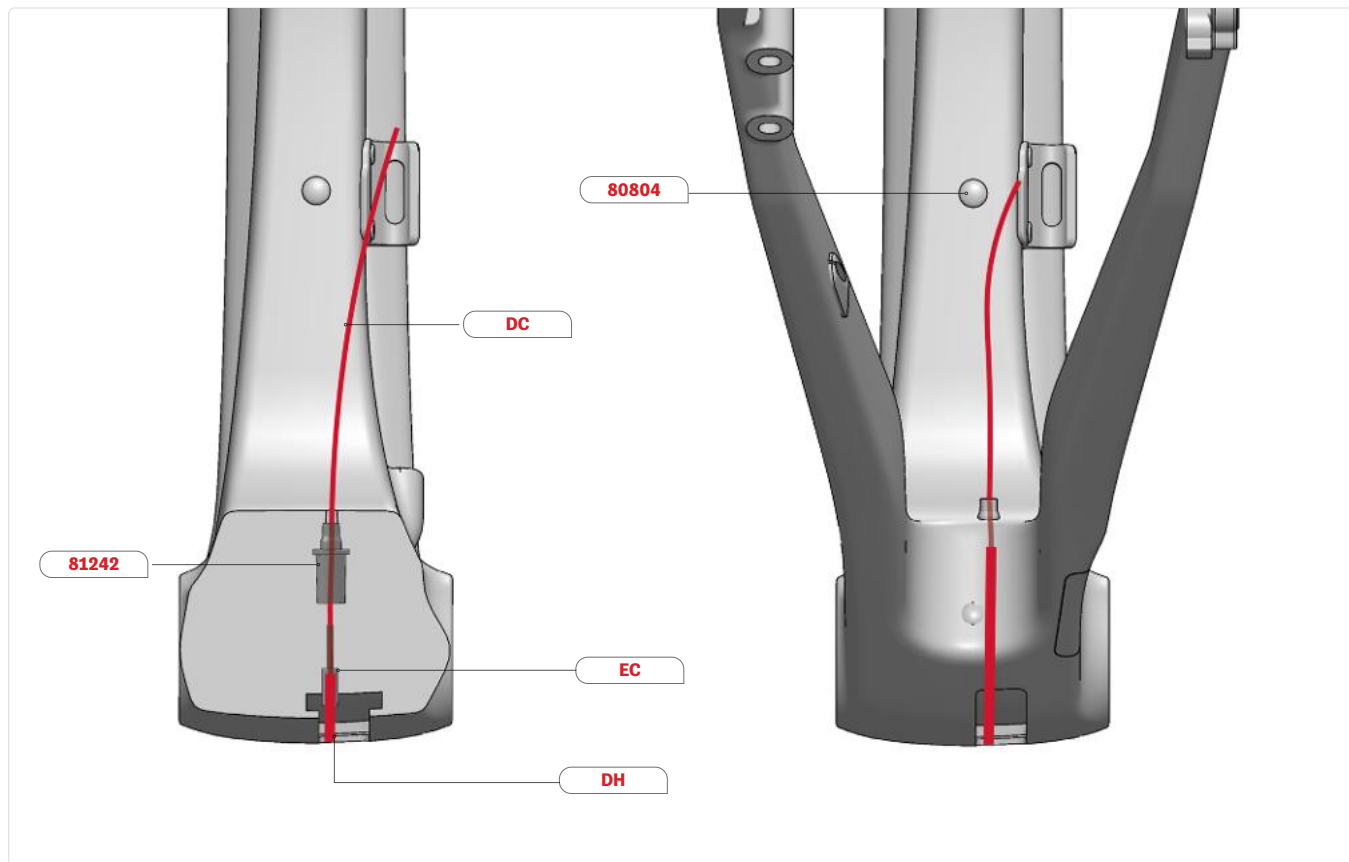

Front Derailleur with cable stop:

1. Insert front derailleur housing (DH) from the headtube.
2. Once the housing exits from the BB hole, install the housing end cap (EC).
3. Install the FD cable stopper (SKU: 81242).
4. Install the front derailleur cable (DC) in the housing.
5. Guide the housing in the hole behind the BB.
6. Install the plug grommet (SKU: 80804) on the Di2 seat tube hole.

9.4 CABLE AND HOUSING ROUTING - MECHANICAL SHIFTING

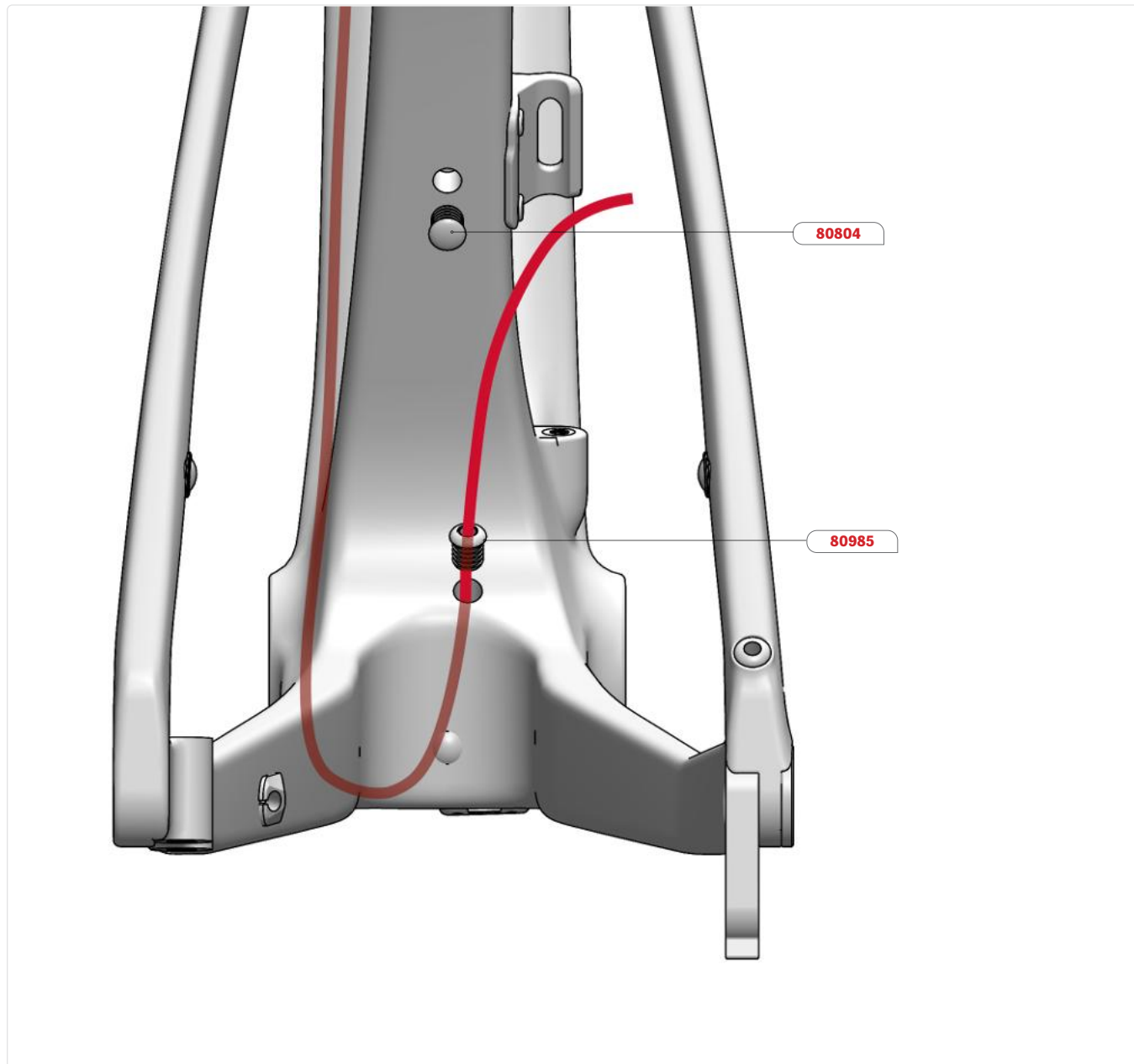

Front derailleur with full housing:

N.B.: Housing length will depend on the derailleur model and the chainring size.

- 1.** Insert the front derailleur housing from the headtube.
- 2.** Once the housing exits from the BB hole, guide the housing in the hole behind the BB.
- 3.** Install the mechanical grommet (SKU: 80985).
- 4.** Install the housing ferrule.
- 5.** Install the plug grommet (SKU: 80804) on the Di2 seat tube hole.

10.1 CABLE AND HOUSING ROUTING - MECHANICAL IX SHIFTING

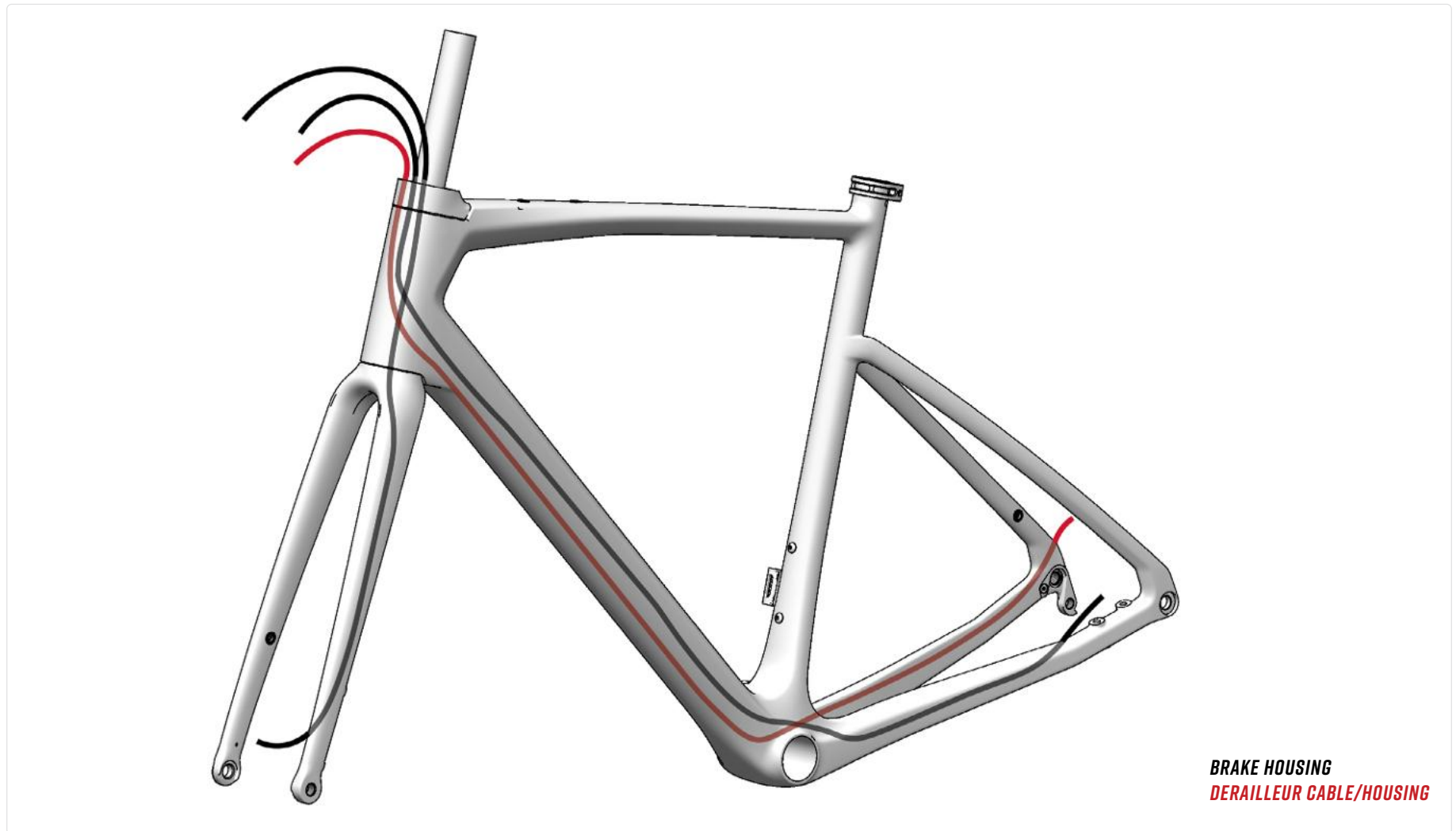

1. The rear brake and rear derailer housing will run above the BB once installed.
2. All housing can be covered by a foam liner (SKU: 80811).
3. Refer to the [Internal Routing Guide](#) on the website for the cable side around the steer tube, this depends on the choice of cockpit.

10.2 CABLE AND HOUSING ROUTING - MECHANICAL IX SHIFTING

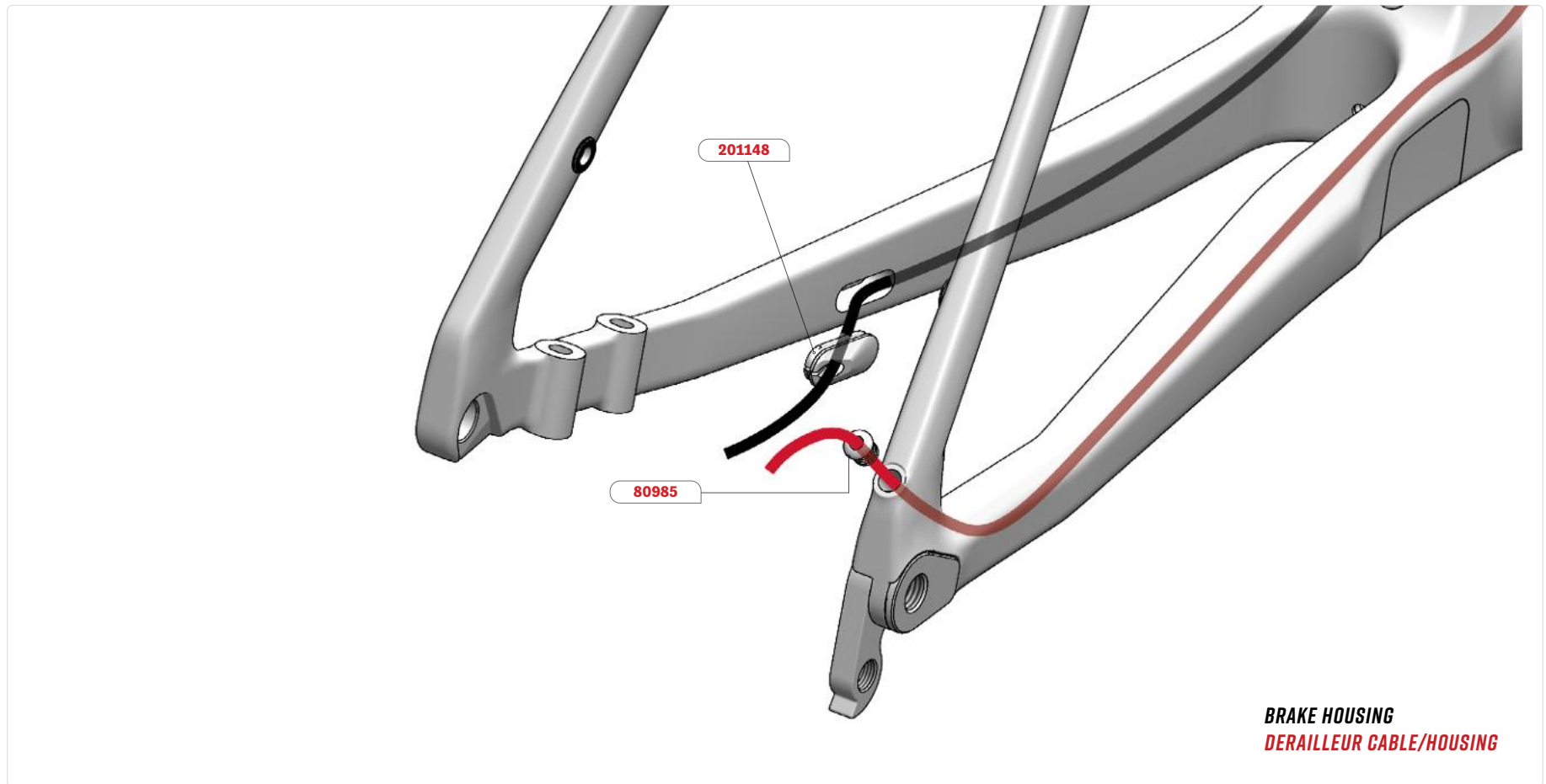

Rear Derailleur:

1. Insert housing from rear hole on the seat stay.
2. Guide the housing over the bottom bracket.
3. Exit the housing through the headtube.
4. Insert the mechanical grommet (SKU: 80985) into the seat stay hole.

Rear Brake:

1. Insert housing from rear hole on the chainstay.
2. Guide the housing over the bottom bracket.
3. Exit the housing through the headtube.
4. Insert the rear brake oblong flat cable guide (SKU: 201148) into the chainstay hole.

10.3 CABLE AND HOUSING ROUTING - MECHANICAL IX SHIFTING

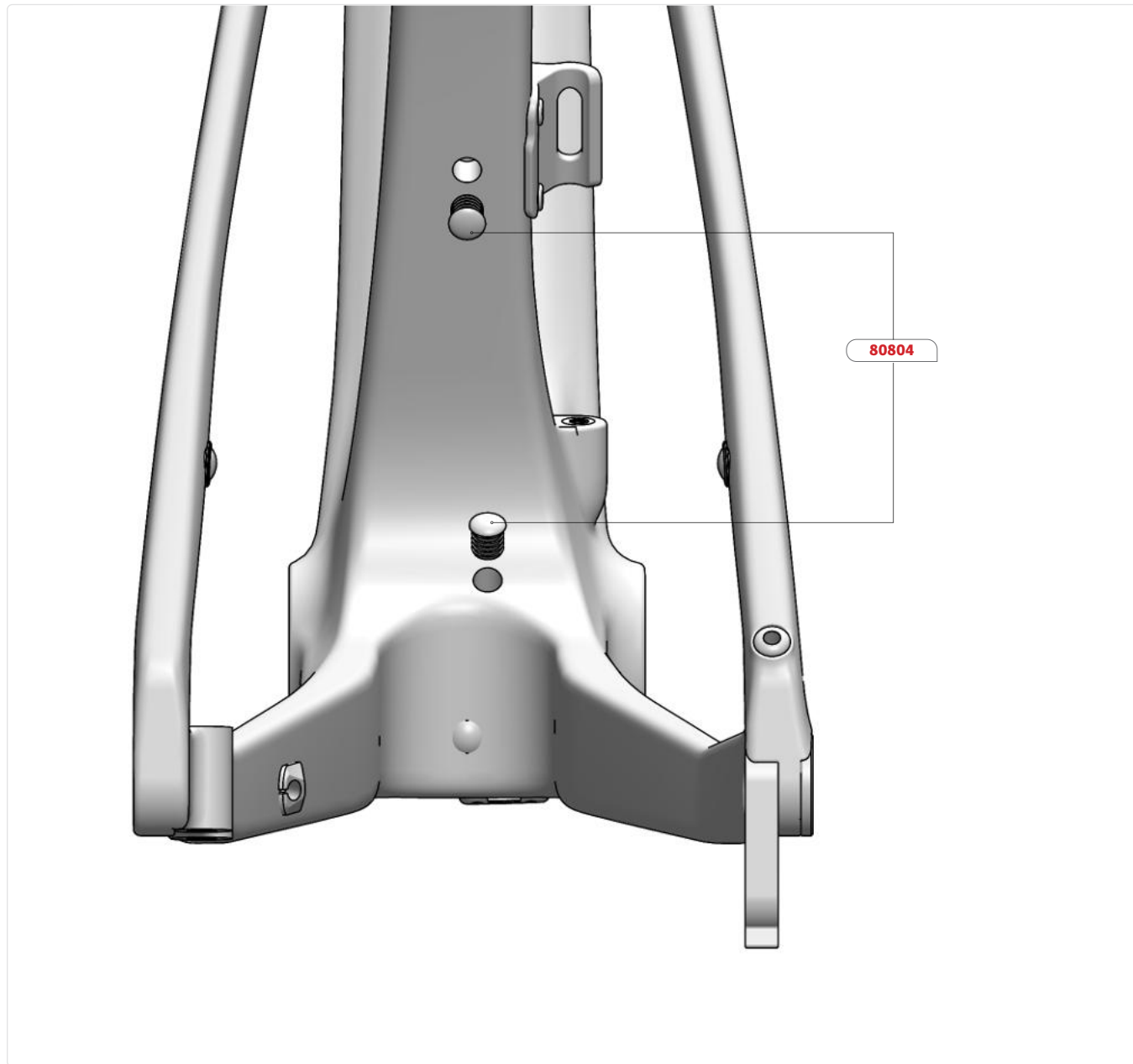

I. Install the plug grommet (SKU: 80804) in the Di2 seat tube hole and FD housing exit hole.

1.1 CABLE AND HOUSING ROUTING - ELECTRONIC WIRELESS ROUTING



1. The rear brake housing will run above the BB once installed.
2. The rear brake housing can be covered by a foam liner (SKU: 80811).
3. Refer to the [Internal Routing Guide](#) on the website for the cable side around the steer tube, this depends on the choice of cockpit.

11.2 CABLE AND HOUSING ROUTING - ELECTRONIC WIRELESS ROUTING

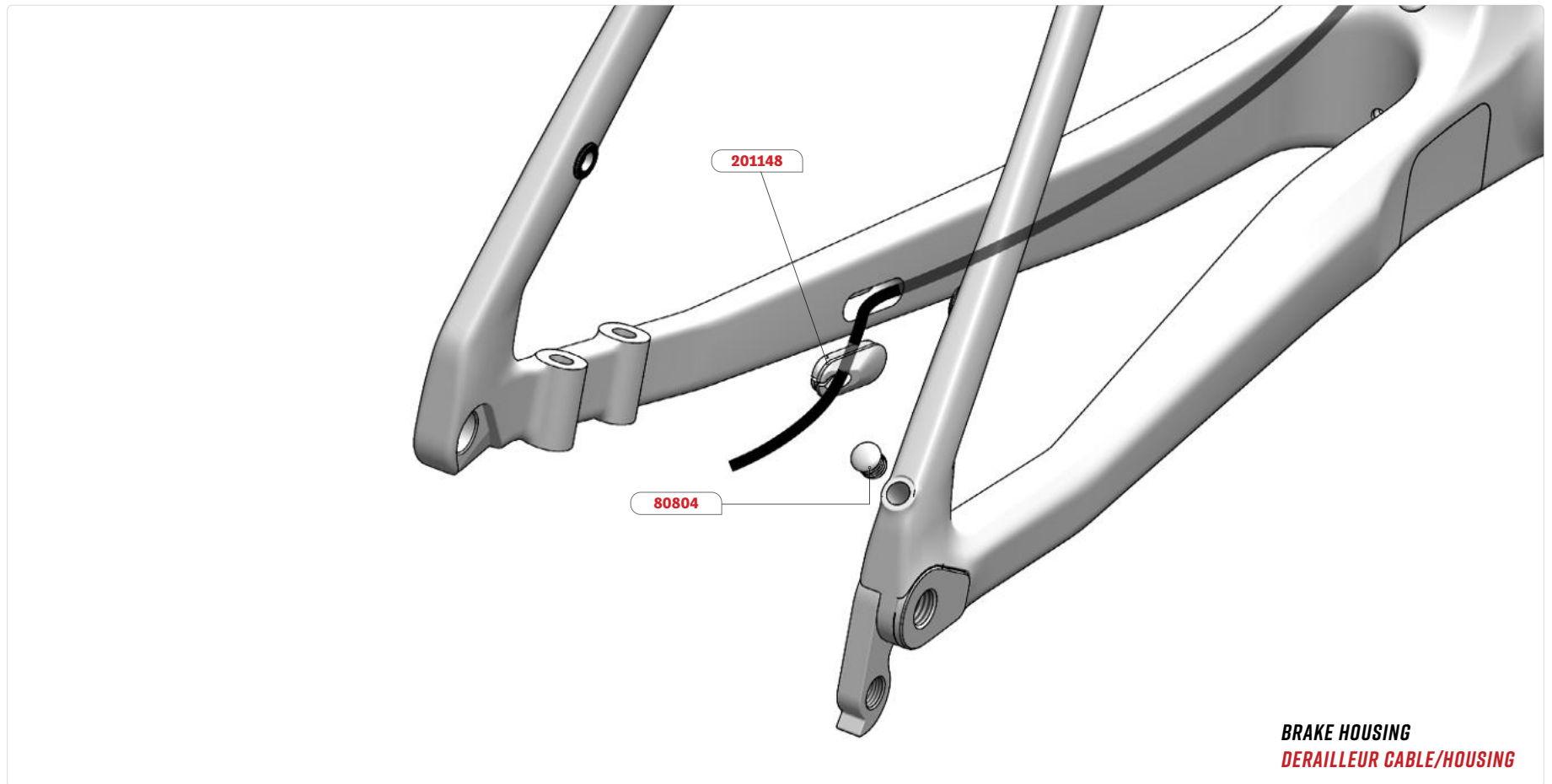

Rear Derailleur:

1. Install the plug grommet (SKU: 80804) in the seat stay hole.

Rear Brake:

1. Insert housing from rear hole on the chainstay.
2. Guide the housing over the bottom bracket.
3. Exit the housing through the headtube.
4. Insert the rear brake oblong flat cable guide (SKU: 201148) into the chainstay hole.

11.3 CABLE AND HOUSING ROUTING - ELECTRONIC WIRELESS ROUTING

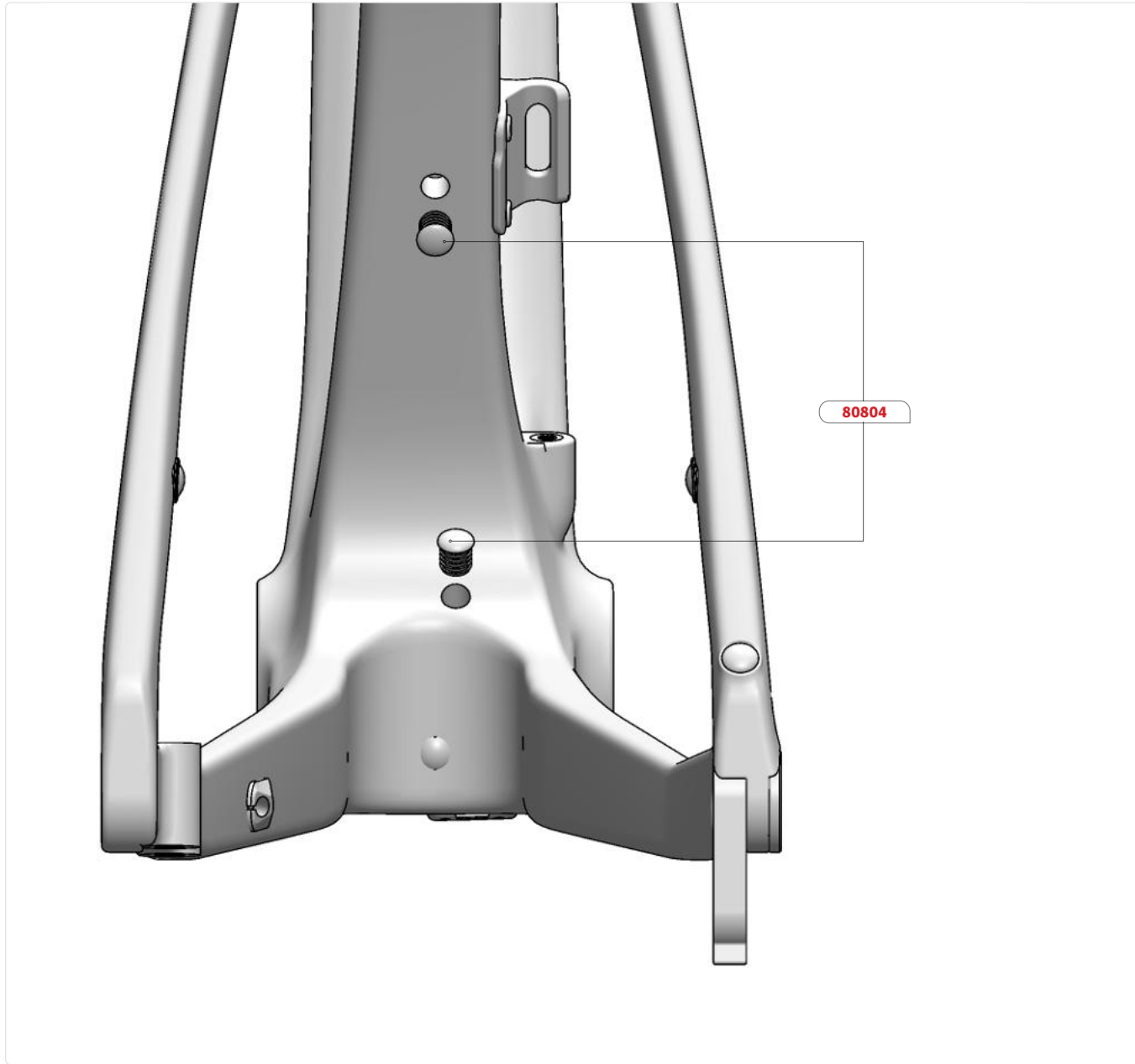

1. Install the plug grommet (SKU: 80804) in the Di2 seat tube hole and FD housing exit hole.

12.1 CABLE AND HOUSING ROUTING - ELECTRONIC WIRE ROUTING



Available separately

9200 - 8100 - 7100

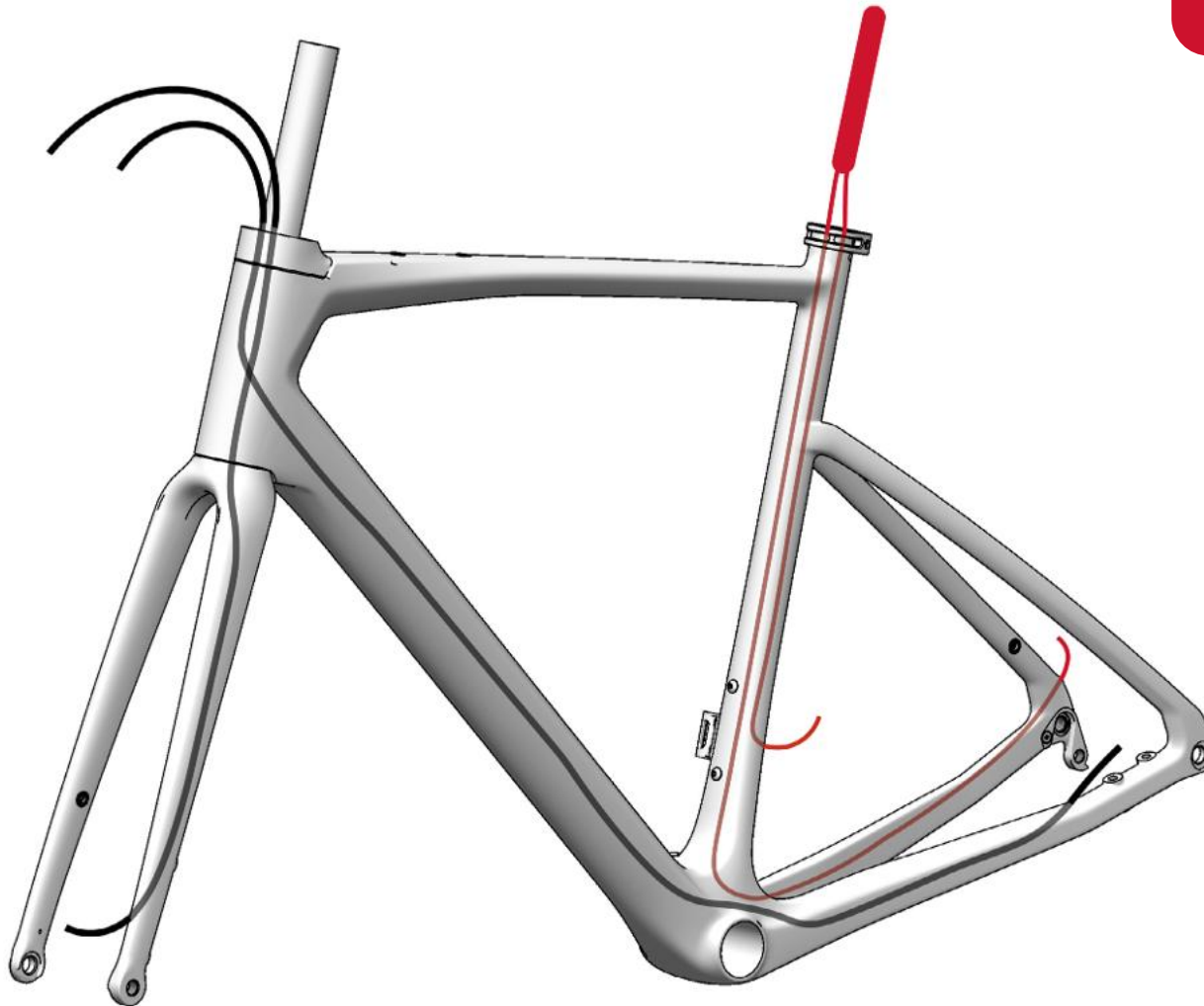

BRAKE HOUSING
DERAILLEUR CABLE

1. The rear brake housing will run above the BB once installed.
2. Derailleurs cable will be over the BB once installed.
3. The rear brake housing can be covered by a foam liner (SKU: 80811).
4. Refer to the [Internal Routing Guide](#) on the website for the cable side around the steer tube, this depends on the choice of cockpit.

12.2 CABLE AND HOUSING ROUTING - ELECTRONIC WIRE ROUTING



- 1.** The rear brake housing will run above the BB once installed.
- 2.** Derailleur cable will be over the BB once installed and junction box in front of the BB.
- 3.** The rear brake housing can be covered by a foam liner (SKU: 80811).
- 4.** Refer to the [Internal Routing Guide](#) on the website for the cable side around the steer tube, this depends on the choice of cockpit.

12.3 CABLE AND HOUSING ROUTING - ELECTRONIC WIRE ROUTING

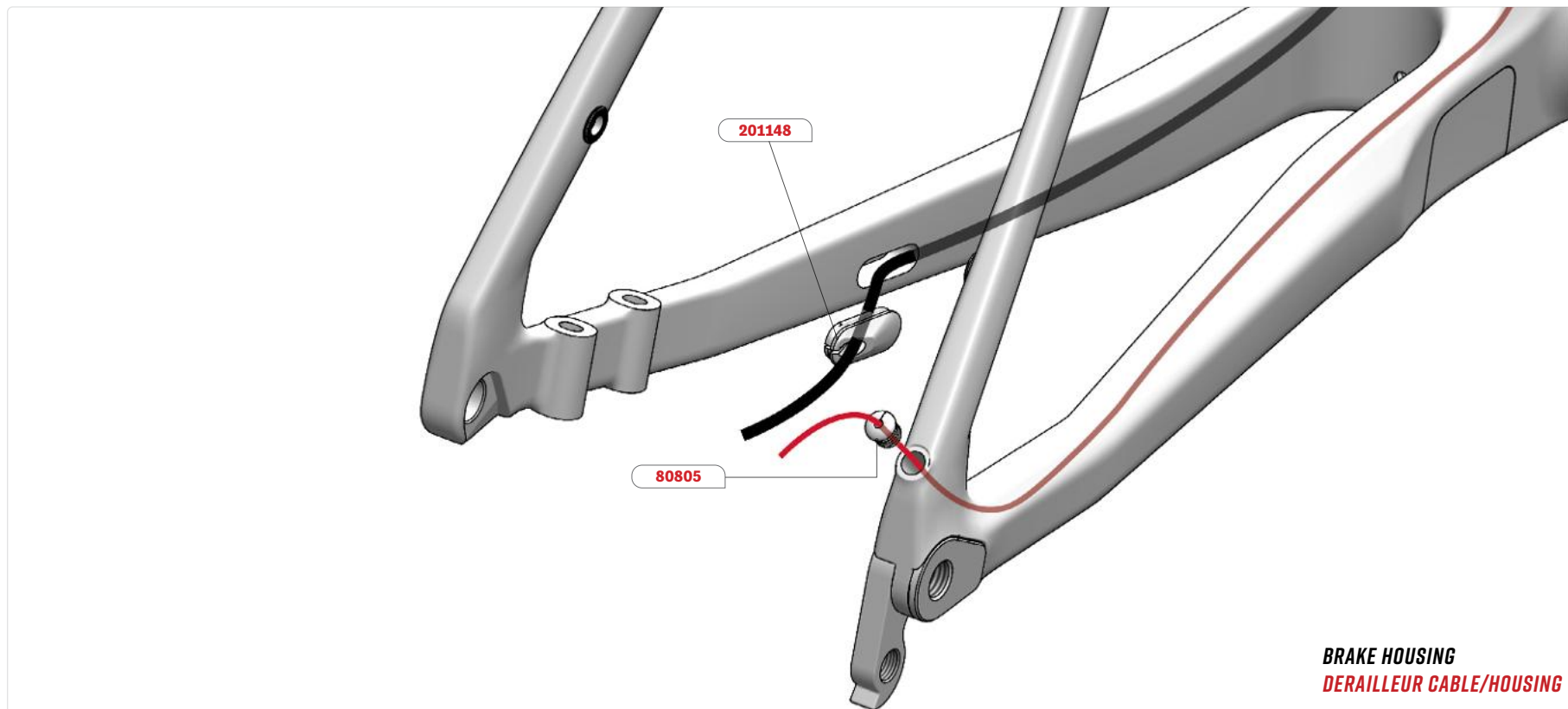

Rear Derailleur:

1. Insert the Di2 rear derailleur cable from rear hole on the seat stay until it exits from the BB hole or the seattube depending on the Di2 generation.
2. Plug the cable to the junction box if older Di2 generation.
3. Insert the Di2 grommet (SKU: 80805) into the seat stay hole.

Rear Brake:

1. Insert housing from rear hole on the chainstay.
2. Guide the housing over the bottom bracket.
3. Exit the housing through the headtube.
4. Insert the rear brake oblong flat cable guide (SKU: 201148) into the chainstay hole.

12.4 CABLE AND HOUSING ROUTING - ELECTRONIC WIRE ROUTING

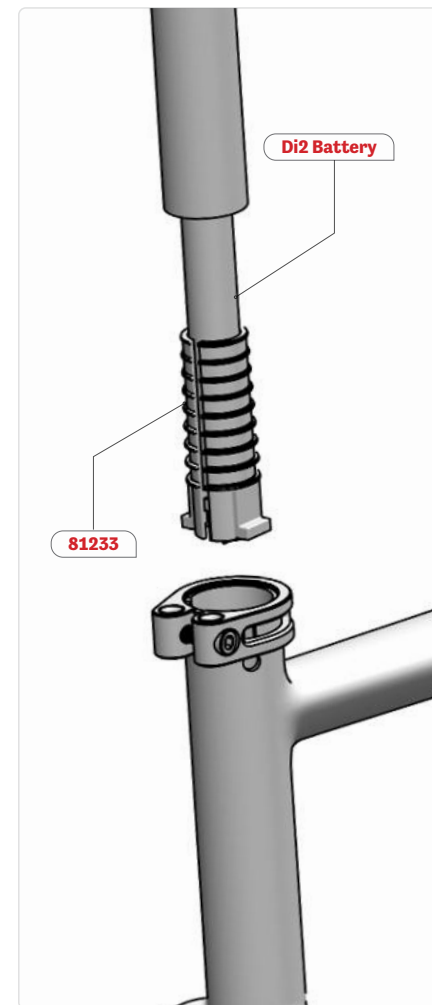
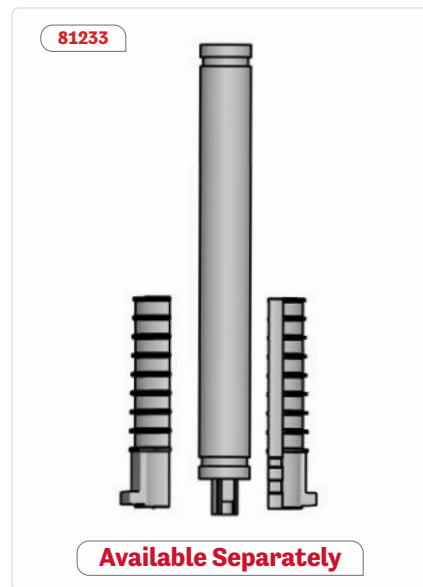
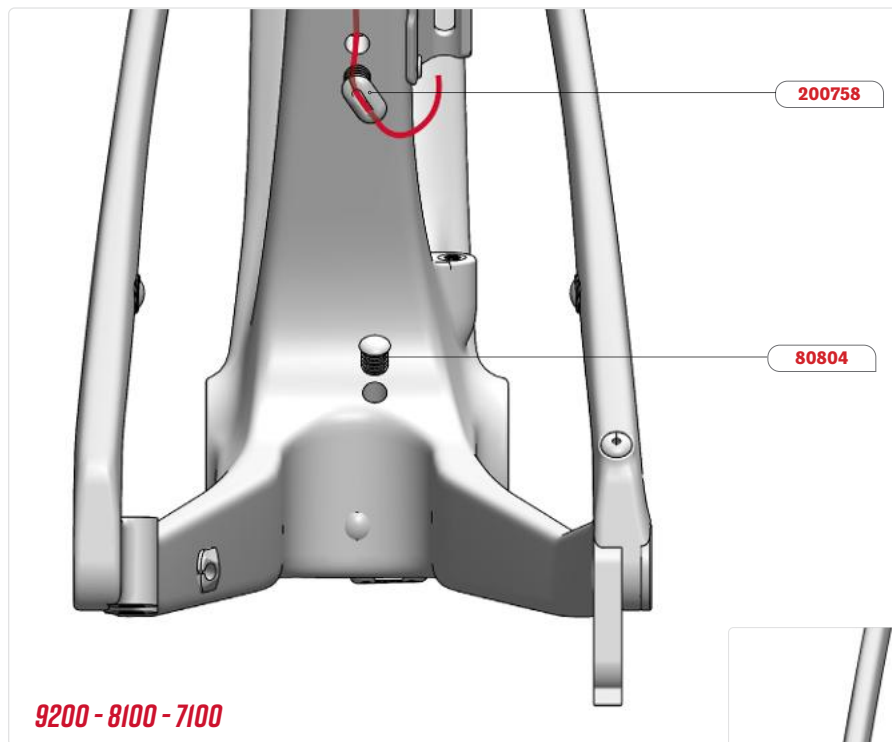

1. Install the Di2 battery in the seatpost using the rubber battery holder.
2. Insert Di2 front derailleur cable from hole behind seat tube until it exits from the BB hole or the seattube depending on the Di2 generation.
3. Plug the front derailleur cable into the junction box or both cable in the battery.
4. If older generation Di2, run a cable from the battery to the junction box, and one from the Headtube to the junction box.
5. Install the plug grommet (SKU: 80804) in the FD housing exit hole and the Di2 angled grommet (SKU: 200758) into the Di2 seat tube hole.

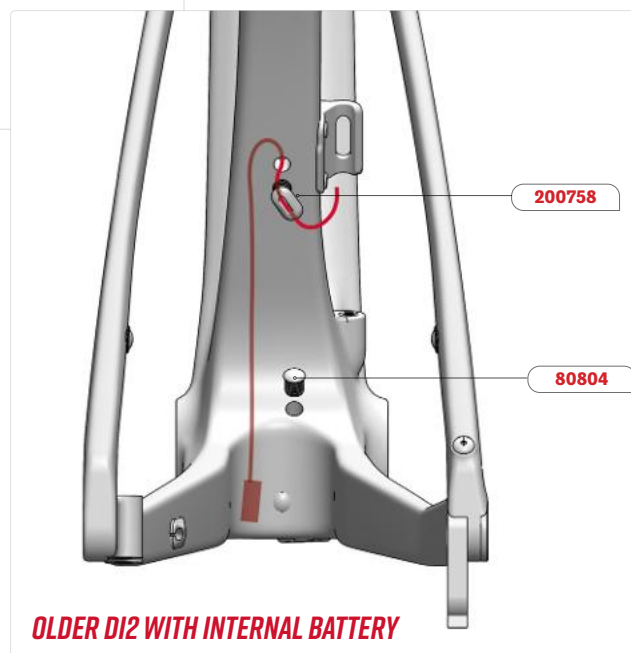

13. FORK INSTALLATION

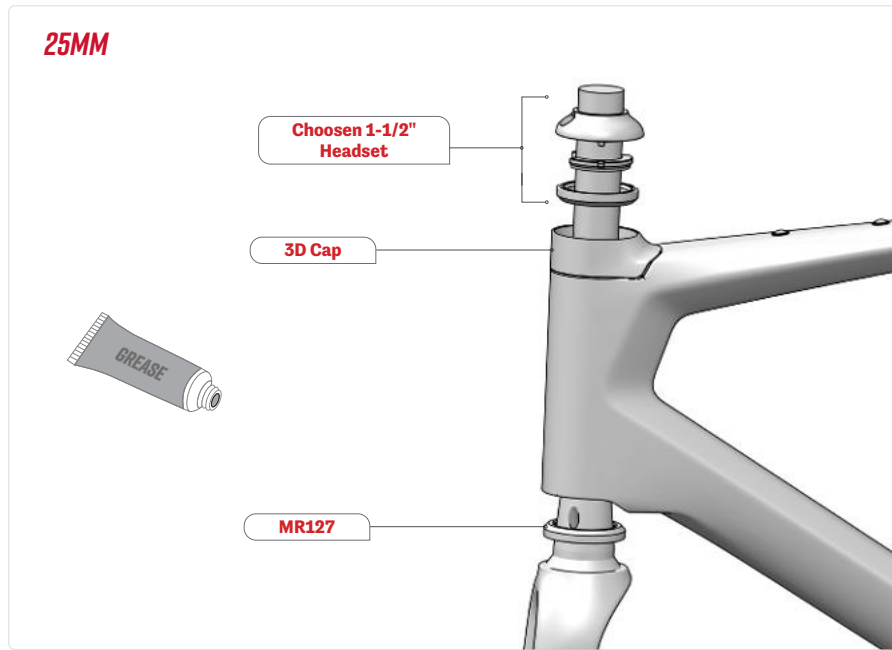

25mm assembly process:

1. Install the bottom (MR127) bearing on the fork. (Apply grease on both side of the bearing)
2. Insert top bearing (Supplied with the headset) in the headset column. (Apply grease on both side of the bearing)
3. Slide the fork into the head tube while orienting all housing on the good side of the steer tube.
4. Install conical compressor ring with all cable at the right place.
5. Install headset top cover with all cable at the right place.
6. For more information on compatible system and assembly suggestion, please see: [Internal Routing Guide](#) on our website.

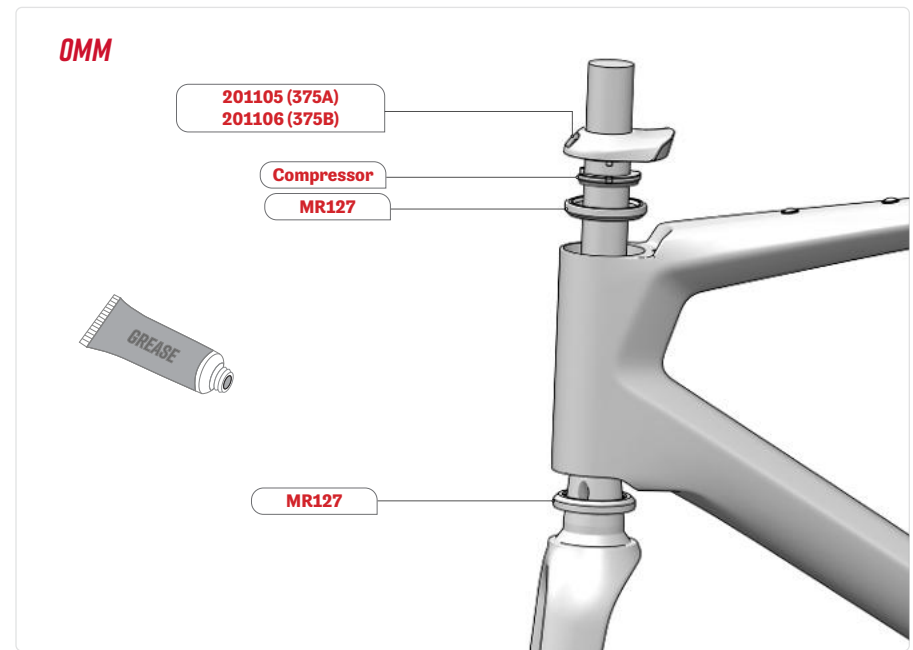

0mm assembly process:

Please note that this cap is designed to replace a SRS headset topcap.

1. Install the bottom (MR127) bearing on the fork. (Apply grease on both side of the bearing)
2. Insert top bearing (MR127) in the headset column. (Apply grease on both side of the bearing)
3. Slide the fork into the head tube while orienting all housing on the good side of the steer tube. For SRS system, we suggest that all cable pass on the same side of the steerer as the lever their going to.
4. Install conical FSA compressor ring with all cable at the right place.
5. Install headset top cover (SKU: 201105 or 201106) with all cable at the right place.



IMPORTANT:

Only 4 cables can pass thru the headset per headset manufacturer recommendation.

14. STEM INSTALLATION

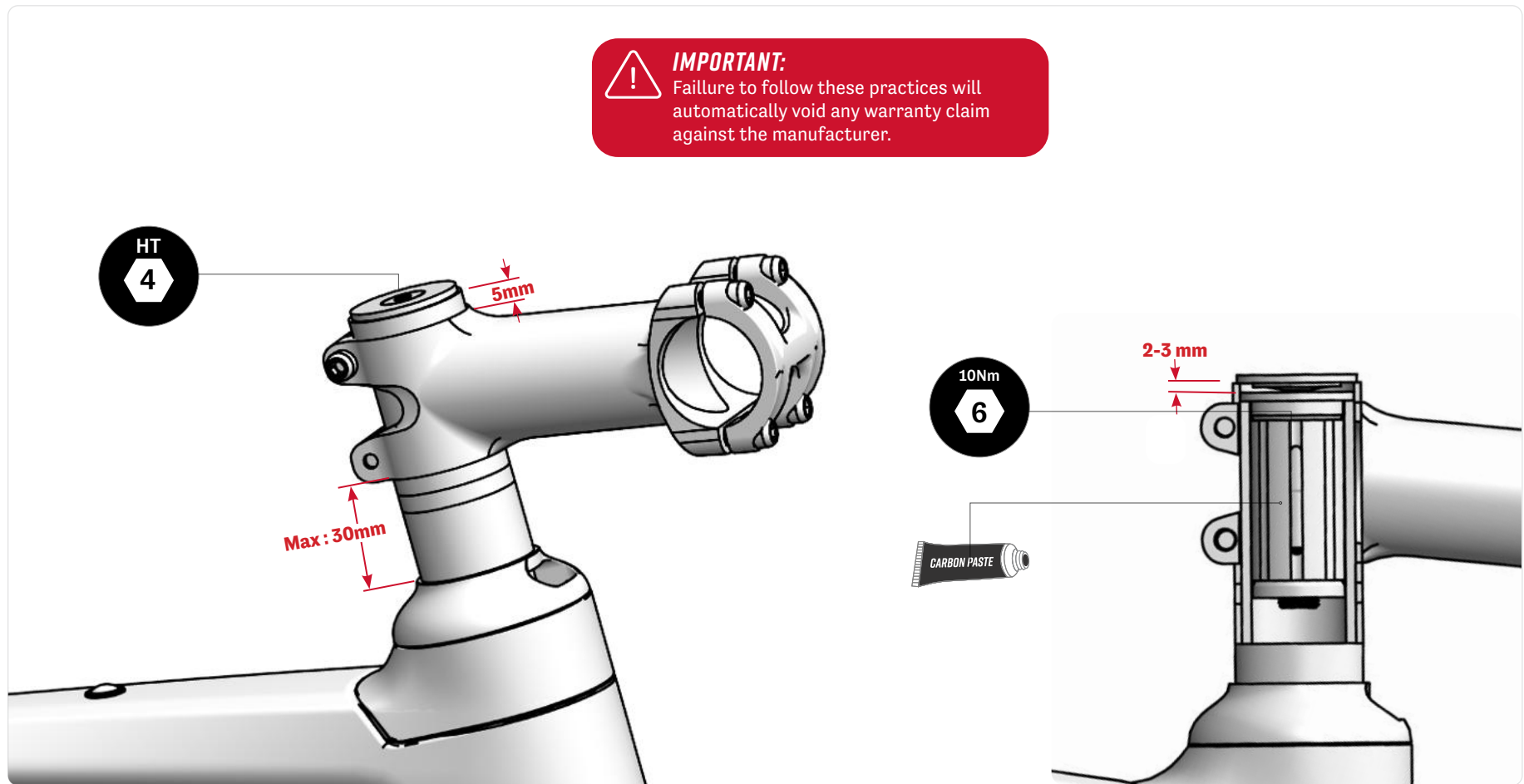

Important:

- No more than 30mm of spacers can be placed between the stem and the top cap of the Headset.
- It is critical to assemble the headset expander plug at the same height as the stem's steerer clamp.

Installing the stem:

1. Cut the steerer so a 5mm spacer can be used on top of the stem. This will ensure the stem clamping area is fully supported by the carbon steerer.
2. Apply carbon paste between compression plug and steerer. Tighten expander plug to 10Nm.
3. Tighten the compression screw until there's no play in the headset bearing. Make sure there's 2 to 3 mm of gap to allow headset adjustment.
4. Align the stem and torque the bolts to the manufacturer recommended torque.

15. CHAIN CATCHER

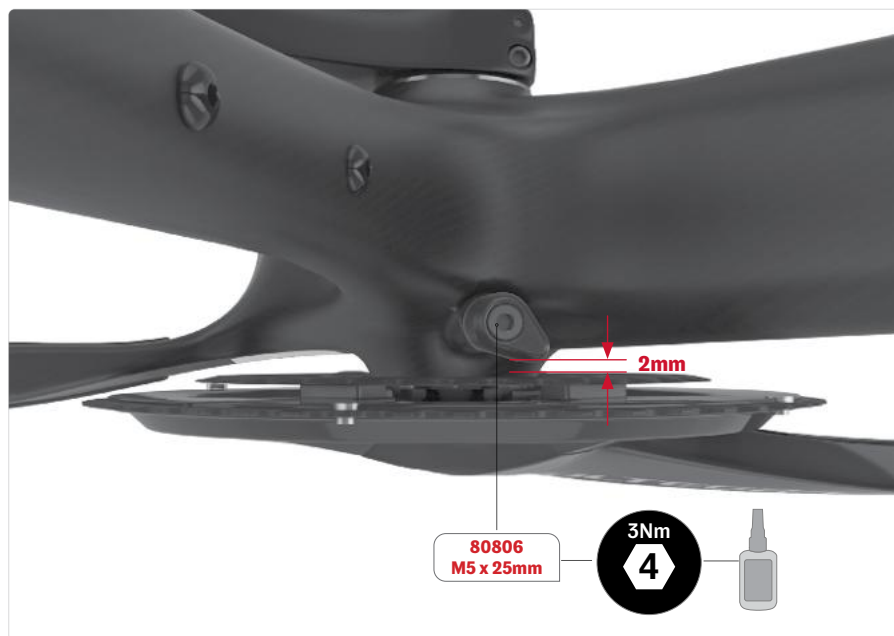
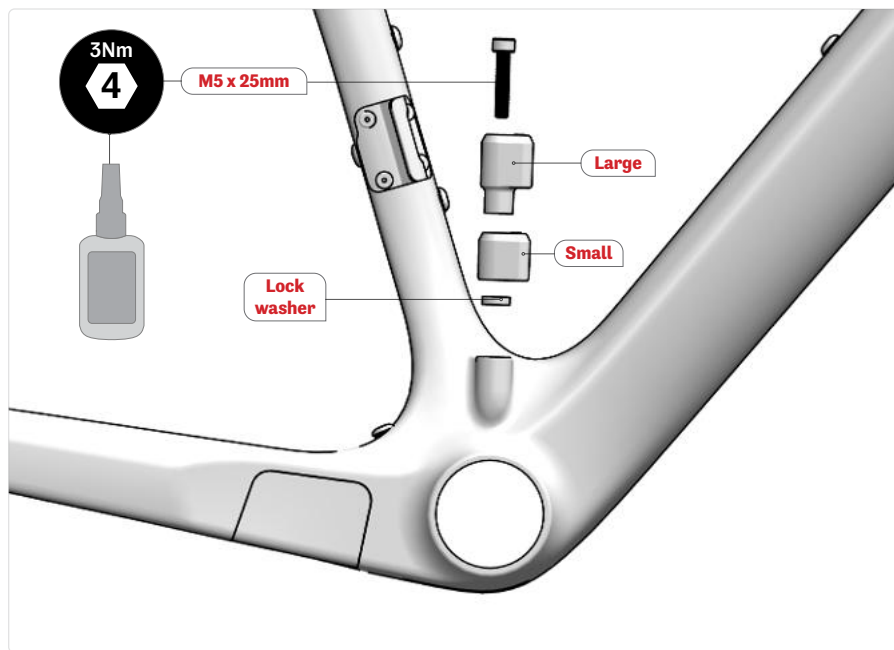

1. Select the appropriate chain catcher (SKU: 80806). The selection of the correct chain catcher is made according to the size of the small chainring.

SMALL CHAIN RING SIZE	CHAIN CATCHER
34-36	Small
38-42	Large

2. Apply a drop of blue threadlocker (no. 242) to the thread of the M5 x 25mm screw.
3. Insert the M5 x 25mm screw in the chain catcher and place the lock washer between the frame and the piece. Secure the assembly pointing forward, loose enough to be able to adjust the parts.
4. Install the crank according to manufacturer's specifications.
5. Place the tip of the chain catcher at approximately 2mm to the inner side of the small chain ring and torque at 3Nm.

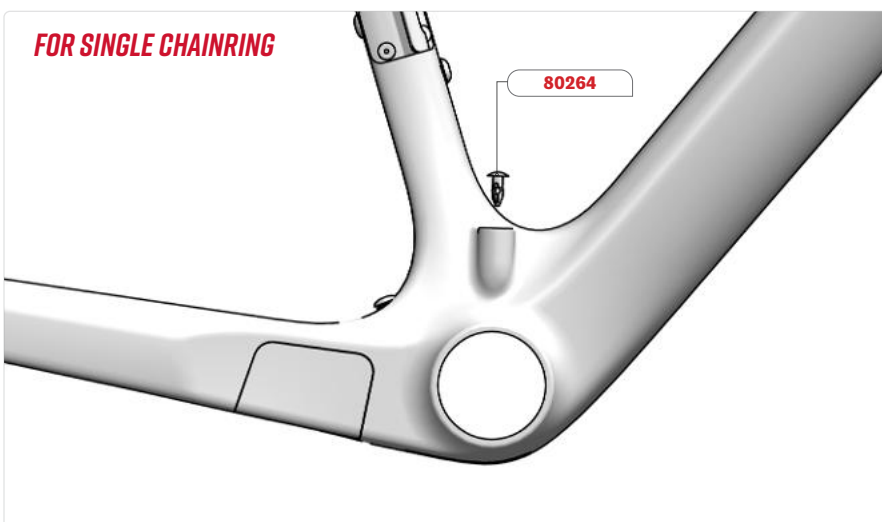

1. Install a M5 plug (SKU: 80264) over the chain catcher hole.

16. FENDER INSTALLATION

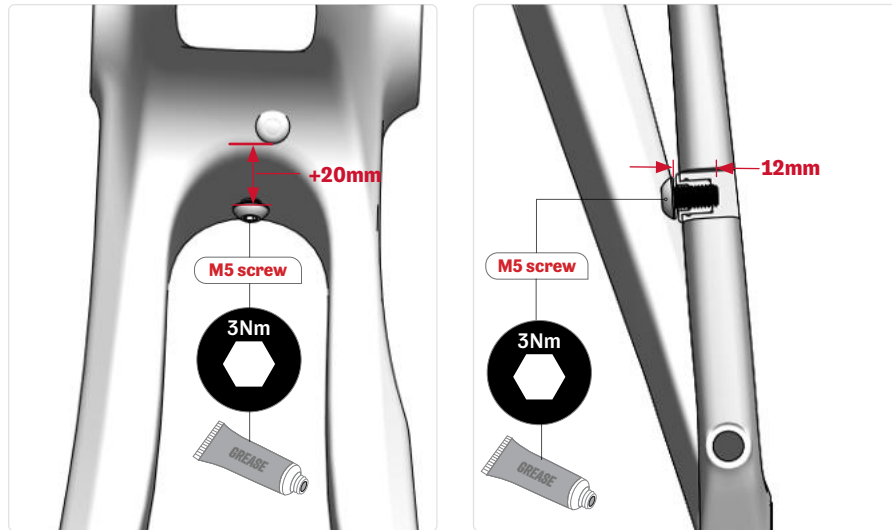

1. When securing the fender on the seatstay, the maximum insertion of the screw is 12mm to avoid protrusion and possible seatstay damage.
 2. According to the model of fender using place the bracket at the correct height on the seatstay. Secure the fender bracket with the 2 attached rubber band making sure that the 2 plastic parts are well over lapping. Attach the fender using a M5 screw and nut.
 3. On the chainstay bridge, behind the BB, the thread length is over 20mm.
 4. When securing the fender on the fork leg, the maximum insertion of the screw is 14mm to avoid protrusion and possible fork damage.
 5. The thread length on the rear upper screw is 10mm.
- * All screws must be torqued to a maximum of 3Nm. Apply grease to the threads.

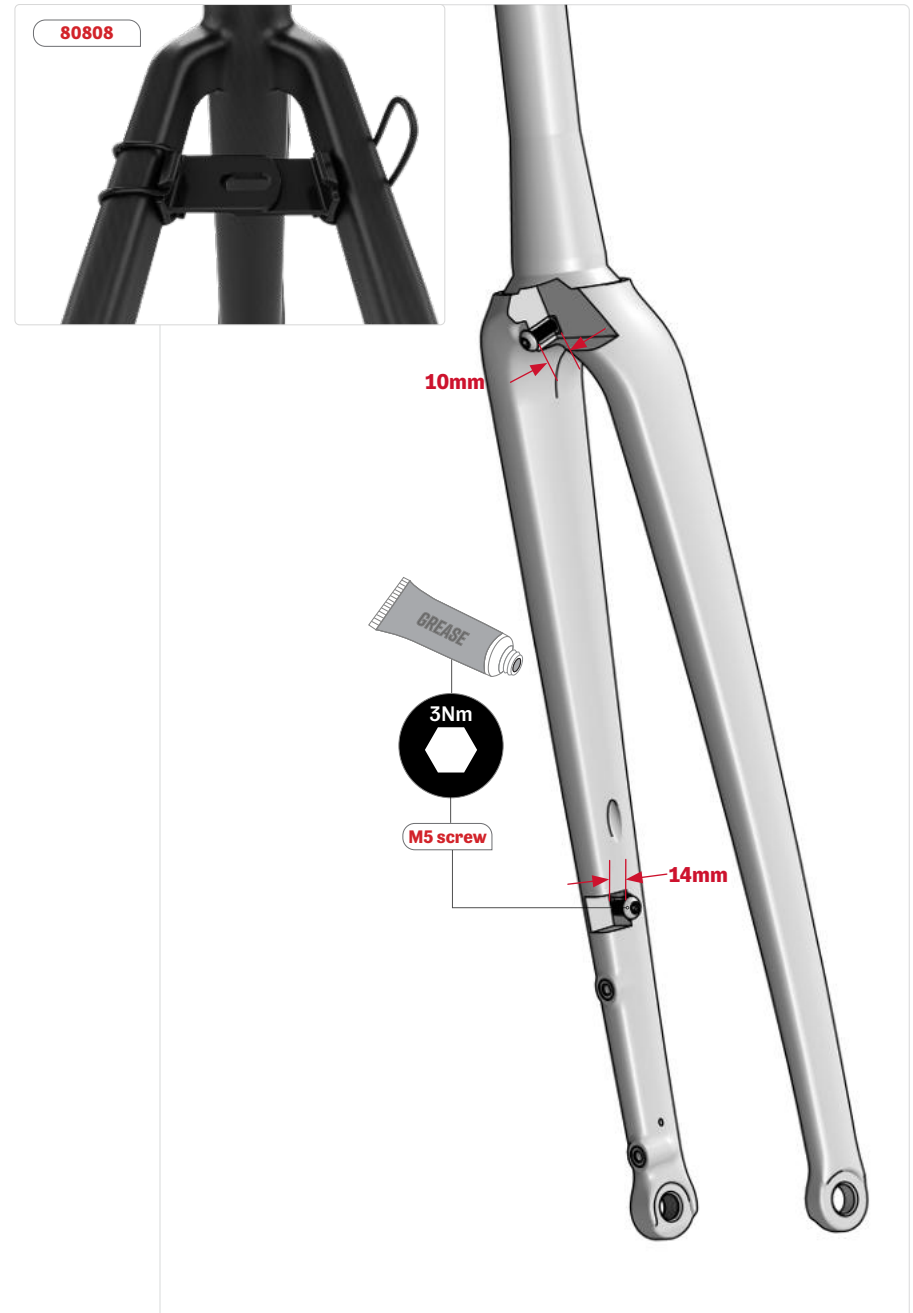

17. BB CAP AND PLUG INSTALLATION

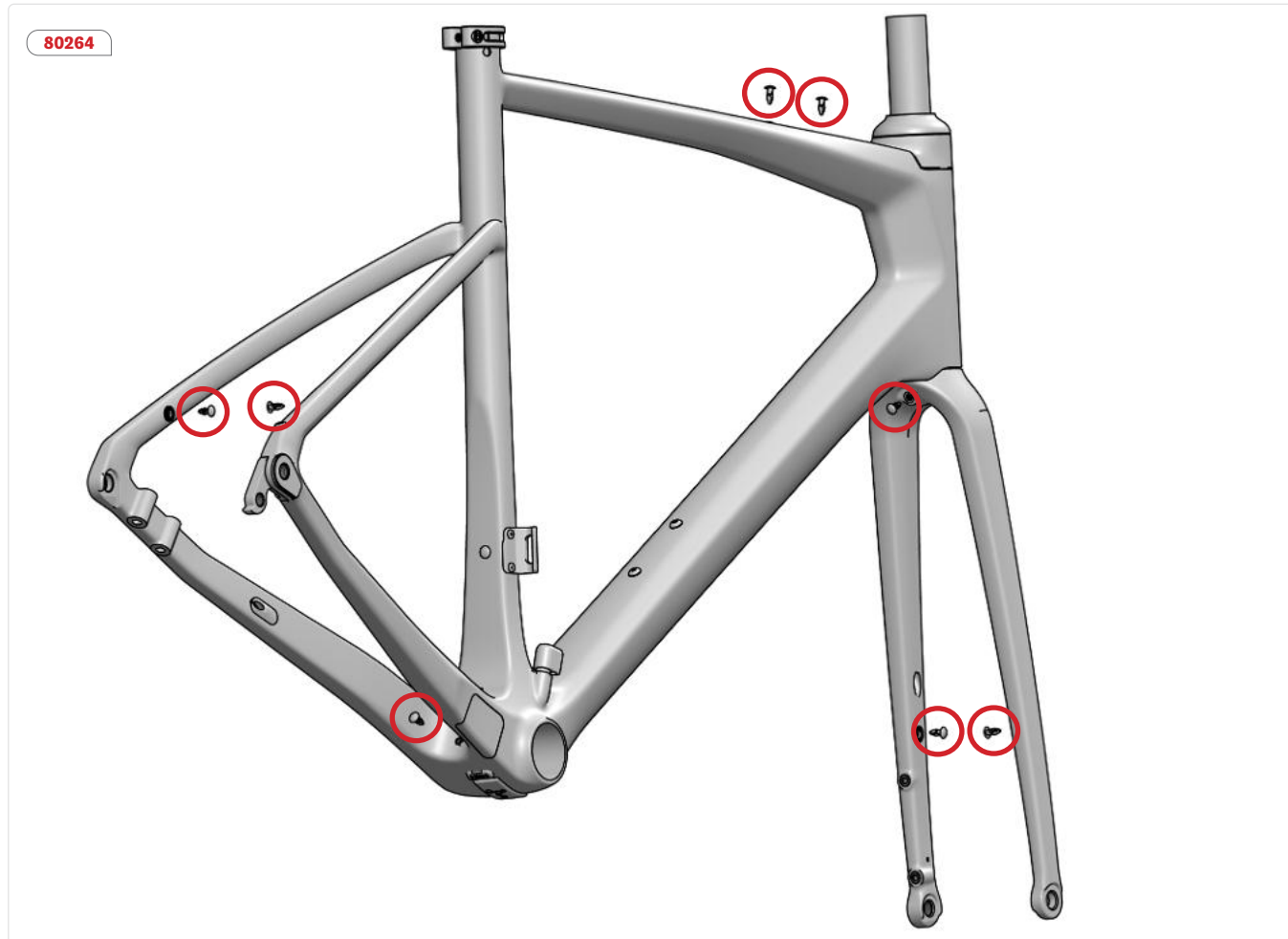

1. Install the BB cover (80548) to cover the BB hole, watch for orientation.
2. Plug all unused hole on the frame and fork with M5 plastic plug (80264).