

# ARGON 18



VALID FOR NITROGEN PRO 383A / NITROGEN 384A-B

NITROGEN PRO

# ARGON 18



VALID FOR NITROGEN PRO 383A / NITROGEN 384A-B

NITROGEN

# ARGON 18



VALID FOR NITROGEN PRO 383A / NITROGEN 384A-B

NITROGEN

# TABLE OF CONTENTS

## **NITROGEN & NITROGEN PRO**

1. Tools needed & Spare Parts Kit	5
2. Troubleshooting / Tips & Specifications	6
3. Frameset Inspection	7
4. Frameset Skus & Descriptions	8-9
5. SeatPost Min. & Max. Insertion	10
6. SeatPost Assembly	11-12
7. Rear Derailleur Hanger Installation	13
8. Front Derailleur Hanger Installation	14
9. Brake Routing	15-16
10. Fork Assembly	17
11. Cable and Housing Routing – Electronic Wireless	18
12. Cable and Housing Routing – Electronic Wired	19
13. Bottom Bracket Cover Installation	20
14. Bottle Cages Positions	21

## **ATTEN CHB-01 AERO**

15. Handlebar Specifications	23
16. Handlebar Skus & Descriptions	24-25
17. Handlebar Installation	26-28
18. Computer Mount Installation	29-30
19. Handlebar Installation Non-Integrated	31

*For the warranty to be valid, the bicycle must be fully assembled by an authorized Argon 18 dealer. High-end components, such as carbon parts, require extra care during assembly.*

*These components must be installed using a torque wrench to ensure each bolt is at the specified torque setting to prevent damage.*



### **MY NITROGEN / NITROGEN PRO**

Date of Purchase: \_\_\_\_\_

Retailer: \_\_\_\_\_

Size: \_\_\_\_\_

Serial Number: \_\_\_\_\_

## 1. TOOLS NEEDED & SPARE PARTS KIT

1. Hydraulic Hose Cutter



2. Set of Allen Key



3. Flush Cut Plier



4. Carbon Paste & Grease



5. Utility Picks



6. Clean Rag



7. Derailleur Hanger Alignment Gauge



8. Cables and Housing Cutter



9. Medium-strength Thread Locker



10. Isopropyl Alcohol



11. Torque Wrench



12. Cassette Lockring Tool



13. 8mm Wrench



13. Bleed Kit



14. Set of Torx Key



15. Mineral Oil



## SPARE PARTS KIT



**IMPORTANT:**  
Essential parts to always have on hand.  
IN CASE OF EMERGENCY...  
THIS MIGHT SAVE YOUR RIDE!

1. Seat Post Clamp



201498

2. UDH Rear Derailleur hanger



201345

3. UDH Rear Derailleur hanger Direct Mount



201506

## 2. TROUBLESHOOTING / TIPS & SPECIFICATIONS

### Brakes

Rear brake - 140/160mm disc rotors

Front brake - 140/160mm disc rotors

Rear mount thickness: 20mm.

### Tire Clearance

The biggest tires that can be installed are 700x32c, they must be no wider than 34mm, for the front and rear wheels.

### Rim Clearance

The biggest rims that can be installed are 37mm external width for the front and rear wheels.

### Seat Post

Argon 18 exclusive aero shape seatpost is only compatible with the Nitrogen frame. Two versions are available, both in 350mm length:

- Item # SP.NITP.383A, with a -20mm setback from the seatpost axis
- Item # SP.NITP.383A.OSB, with a +10mm forward position ("zero" setback)

### Saddle Clamp

The saddle clamp is compatible with both Ø 7mm round and oval saddle rail.

### Bottom Bracket

Threaded T47, 85.5mm width

### Headset

Top Bearing: 40.5mm x 49.5mm x 6.5mm x 45° x 45°

Bottom Bearing: 34.1mm x 46.8mm x 7mm x 45° x 45°

The Nitrogen is optimized for our ATTEN handlebar, however, headset cap for the following handlebar are available:

- Item # 201634, IST3 headset cap - Deda Alenara RS
- Item # 201633, IST3 headset cap - FSA ACR / SMR
- Item # 201448, IST3 headset cap - FSA SRS

### Chainring

The Nitrogen family has been designed to work with 50 to 57 teeth round chainrings or oval chainrings with an equivalent max OD of a 57T round chainring in 2x setup. For 1x, max chainring is 56T.

### Seat Post Collar

Argon 18 exclusive, Nitrogen seatpost clamp is **NOT** the same as the Sum, previous Nitrogen, E-117 and E-119 or any other seat clamp model.

### Power Meter

The Nitrogen is designed to work with the majority of the powermeters available on the market.

For **Hub/Wheel based power meters:**

The system must be compatible with a 12mm x 142mm rear thru-axle.

**Please contact your local Argon 18 authorized retailer for confirmation before purchasing.**

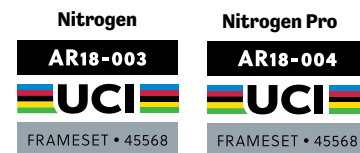

**Please contact customer service at [info@argon18.com](mailto:info@argon18.com) for any further inquiries.**



### 3. FRAMESET INSPECTION

**Before assembling your new Nitrogen, please :**

1. Check you parts against the frameset parts checklist (see p.8-9)
2. Inspect the frame for cosmetic defects (scratches, bumps, cracks, paint defects, etc.)
3. Record serial number on p.4 for reference.
4. Make sure you have all the necessary bolts (refer to frameset parts, p.8-9).

No.	A18 SKU#	Function	Description	Screw Type	Torque	Detail	Qty
1	81499*	Front derailleur hanger screw	M5 x 16mm Screw	Flat head	3 Nm	Grease	2
2	80807	Water bottle screw	M5 x 14mm Screw	Socket Head	2 Nm	Grease	4
3	201498*	Seat post clamp top screw	M8 x 10mm Screw	Set screw	5.5 Nm	Grease	1
4	201498*	Seat post clamp bottom screw	M3 x 6mm Screw	Button Head	Hand Tighten Slack	Loctite	1
5	201104*	Saddle clamp screw	M5 x 40mm Screw	Socket Head	4 Nm	Grease	2
6	201496* / 201497*	BB door screw	M4 x 12mm Screw	Flat head	1Nm	Grease	3
7	201330	Rear Thru Axle	M12 x P1.0 x 167.5mm Axle		10 Nm	Grease	1
8	100161	Front Thru Axle	M12 x P1.5 x 119mm Axle		10 Nm	Grease	1
9	201345	Derailleur Hanger Screw		-	25Nm		1
10	201499*	Stem clamping Screw	M5 x 20mm Screw	Socket Head	6 Nm	Grease	2
11	201501*	Top Cap Screw	M6 x 35mm Screw	Flat head	Hand Tight	Grease	1
12	201502*	Computer mount Fixing Screw	M5 x 12mm Screw	Button Head	2 Nm	Grease	2
13	201502*	Computer mount Accessories Screw	M3 x 8mm Screw	Flat head	Hand Tight	Grease	5

\* Included With



Torque Value  
Allen key size



Apply **carbon paste** on the indicated surfaces.



Apply **threadlocker** on the indicated surfaces.



Apply **grease** on the indicated surfaces.



**IMPORTANT:**

Indicates special precautions and important steps that must be taken to avoid damage and/or injury.

Torque value:  
Under-torquing may cause parts to slip and cause injury.  
Over-torquing may cause screw to break and/or part to slip and cause injury.

# 4.1 FRAMESET PARTS

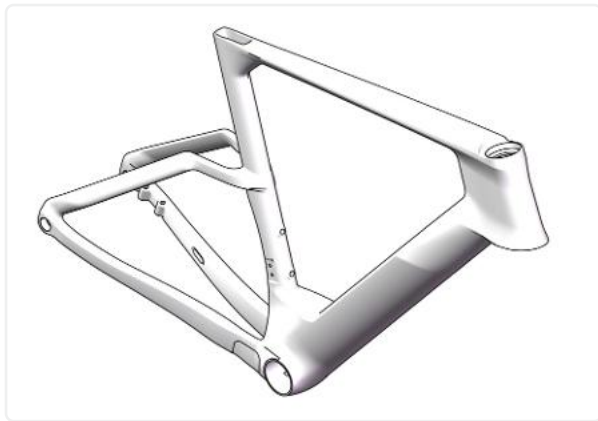

Nitrogen / Nitrogen Pro Frame

\*Not available seprately



FK.NITPS-XL.383A  
FK.NITP.XXS-XS.383A  
FK.NIT.S-XL.384A / 384B  
FK.NIT.XXS-XS.384A / 384B



201104

SP.NITP.383A.OSB

SP.NITP.383A

\* available separately \*



81499



201496 (S-XL)  
201497 (XXS-XS)



201345



100161



201498



201495



201470 (383A)  
201472 (384A)  
201473 (384B)



201500



201188



80100



81054



201330



80264

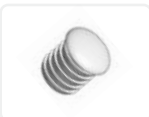

80804



80807



201447



201446



201527



201506



201448



201339



200758



80811



201633



201634

\* available separately \*

\*Except for the frame itself, which is not sold separately as a spare part, all parts can be ordered by using their respective SKU number.

## 4.2 FRAMESET SKUS & DESCRIPTIONS

NO.	NAME	A18 SKU#	QTY
1	NITROGEN PRO Frame -OR- NITROGEN Frame	-	1
2	Chain Suck Guard - NITROGEN	201495	1
3	BB DOOR / BATTERY HOLDER S-XL BB DOOR / BATTERY HOLDER XXS-XS	201496 201497	1
4	Front Derailleur Hanger removable (incl. screws)	81499	1
5	Watter Bottle Screw - M5 x 14mm	80807	4
6	Plastic Plug M5	80264	3
7	NITROGEN PRO Fork (S-M-L-XL), 45mm rake NITROGEN PRO Fork (XXS-XS), 49mm rake NITROGEN Fork (S-M-L-XL), 45mm rake NITROGEN Fork (XXS-XS), 49mm rake	FK.NITP.S-XL.383A FK.NITP.XXS-XS.383A FK.NIT.S-XL.384A / 384B FK.NIT.XXS-XS.384A / 384B	1
8	NITROGEN PRO seatpost assembly	SP.NITP.383A	1
9	NITROGEN PRO saddle clamp (incl. hardware)	201104	1 kit
10	NITROGEN PRO / NITROGEN Headset cap	201470 (383A) / 201472 (384A) / 201473 (384B)	1
11	Compression ring (Bearing ID 40,5 x 45deg)	201500	1
12	Top Bearing - 40.5x49.5x6.5	201188	1
13	Bottom bearing - MR168	80100	1
14	NITROGEN Seatpost wedge assembly	201498	1 kit
15	ANGLED GROMMET Di2	200758	2
16	LONG PLUG	80804	2
17	OBLONG GROMMET	201339	1
18	NITROGEN DOWN TUBE AERO BOTTLE CAGE	201446	1
19	NITROGEN SEAT TUBE AERO BOTTLE CAGE	201447	1
20	SRAM Universal Derailleur Hanger	201345	1
21	GWM THRU AXLE REAR CUSTOM 167.5 X 12 SB-02 LITE & HOLLOW Switch Compatible	201330	1
22	FRONT AXLE 119x12 - LITE & HOLLOW	100161	1
23	Removable lever for GW thru axle 12mm	81054	1
24	Foam liner for hydraulic hose	80811	1
	* Available separately *		
25	Direct mount hanger (UDH)	201506	1
26	IST3 HEADSET CAP SRS	201448	1
27	IST3 HEADSET CAP ACR	201633	1
28	IST3 HEADSET CAP DEDA ALANERA RS	201634	1
29	Seatpost 0 setback	SP.NITP.383A.OSB	1
30	Side load water bottle cage	201527	1

## 5. SEATPOST MIN. & MAX. INSERTION

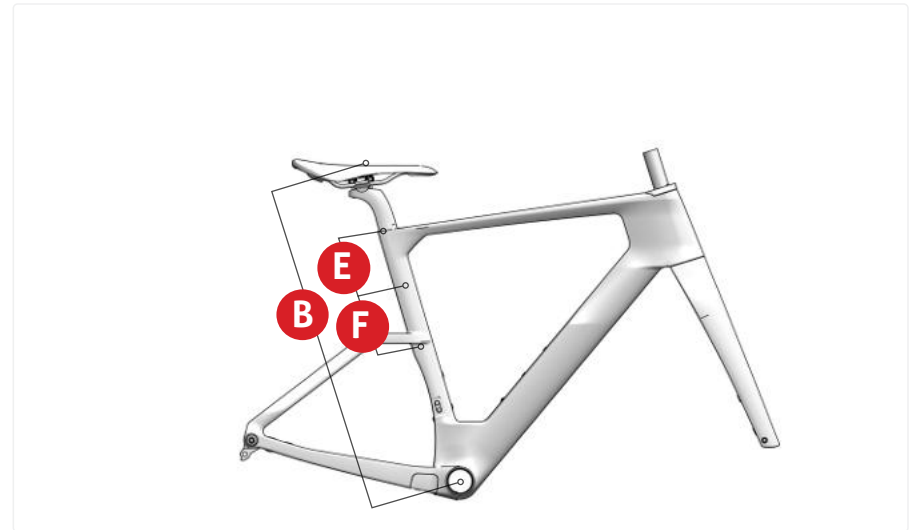
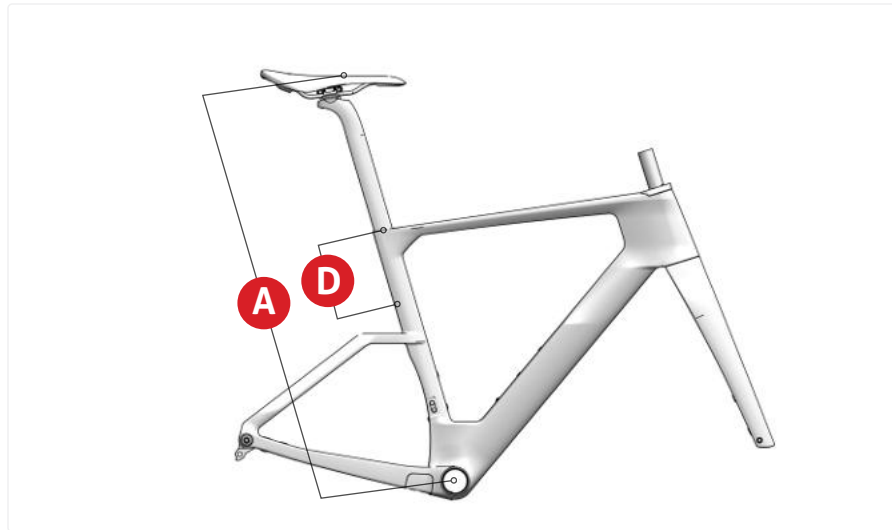

Refer to the adjacent table for details on saddle height and seatpost insertion limits:

i. The correct frame size must be determined according to the saddle height limits.

- A. Maximum Saddle Height.
- B. Minimum Saddle Height.

ii. Depending on the size of the frame and the desired saddle height, the seatpost might need to be cut.

If the desired saddle height is lower than value “C”, calculate the required cutting length “G” as follow:

$$G = C - \text{“Desired saddle height”} + 10\text{mm (to allow adjustment)}$$

**Example:** For a desired saddle height of 615mm on a XX-Small frame, the required minimum seatpost cut length (G) is:

$$G = 645 - 615 + 10 = 40 \text{ mm}$$

**Important:** The saddle height can't be lower than value “B”.

**SADDLE HEIGHT LIMITS (MM)**

SIZE	Max Saddle Height	Min Saddle Height	Min Saddle Height (Without cut)	Min Seatpost Insert	Max Seattube Insert	Max Seat-tube Cut
	A	B	C	D	E	F
XX-SMALL	715	565	645	80	150	80
X-SMALL	745	595	652	80	173	57
SMALL	780	630	658	80	202	28
MEDIUM	825	675	675	80	244	0
LARGE	870	720	720	80	286	0
X-LARGE	915	765	765	80	328	0

\*\*Based on saddle with 50mm between center of rail to top.\*\*

## 6.1 SEATPOST ASSEMBLY

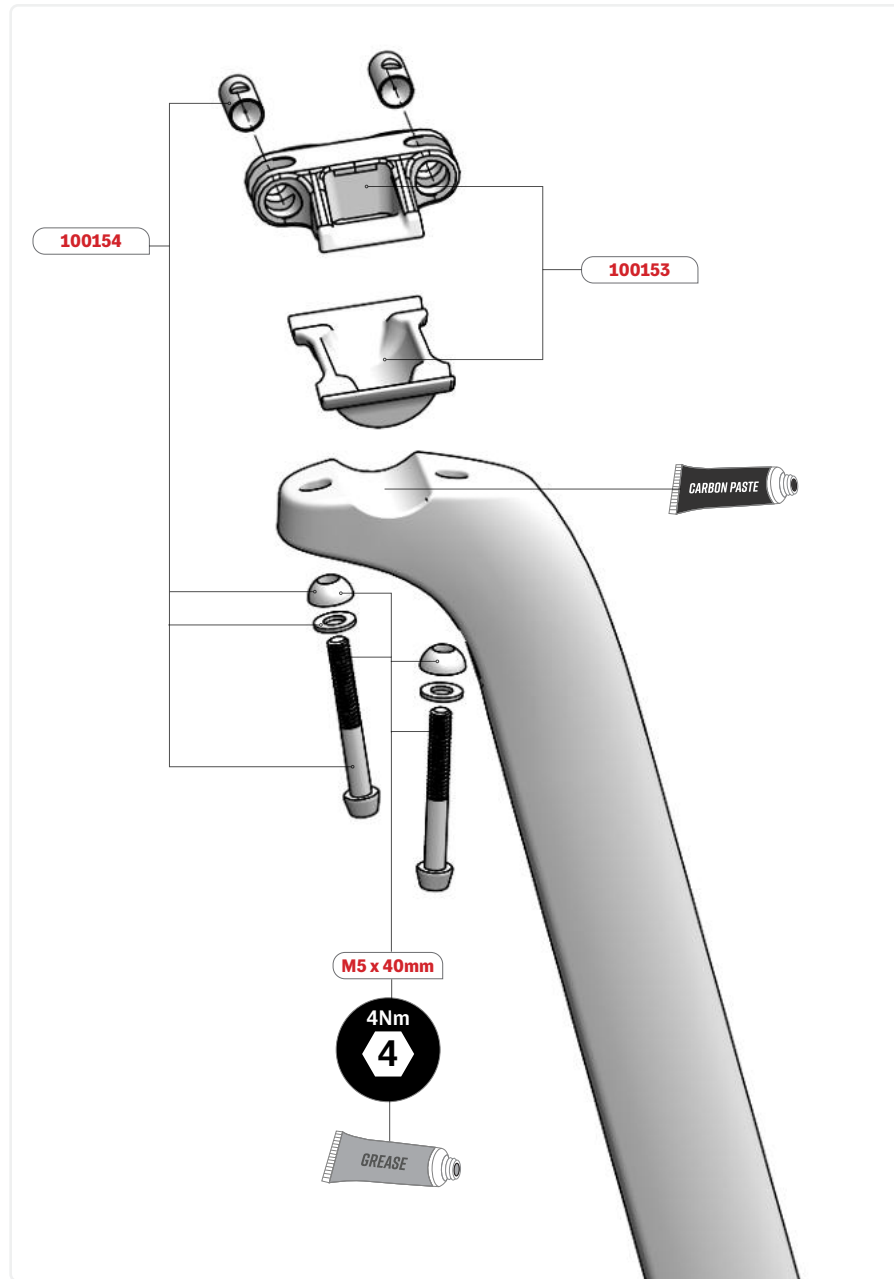

### The seat post is supplied fully assembled\*

1. Loosen the two M5 x 40mm screw to allow the seat post head assembly to move.
2. Apply grease on the threads of each M5 x 40mm screw, on the spherical washer and on the barrel.
3. Apply Carbon paste on the curved face of the seatpost shaft.
4. Install the saddle rails into the seatpost clamp.
5. Tighten both M5 x 40mm screws in order to adjust the angle of the saddle and clamp the rail.
6. Tighten both M5 x 40mm screws to 4Nm.



### IMPORTANT:

Refer to p.10 for seatpost  
**MIN** and **MAX** insertion limits.

## 6.2 SEATPOST INSTALLATION

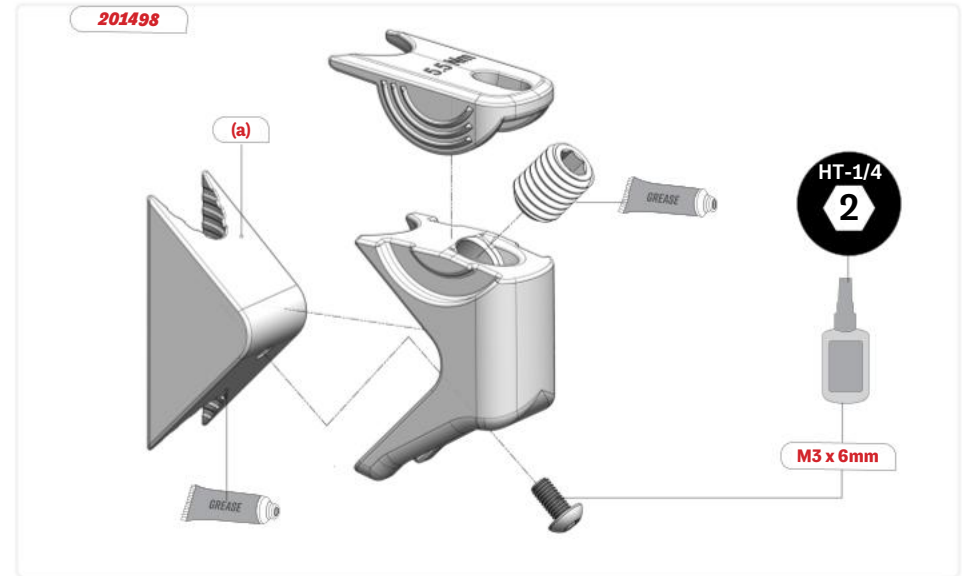
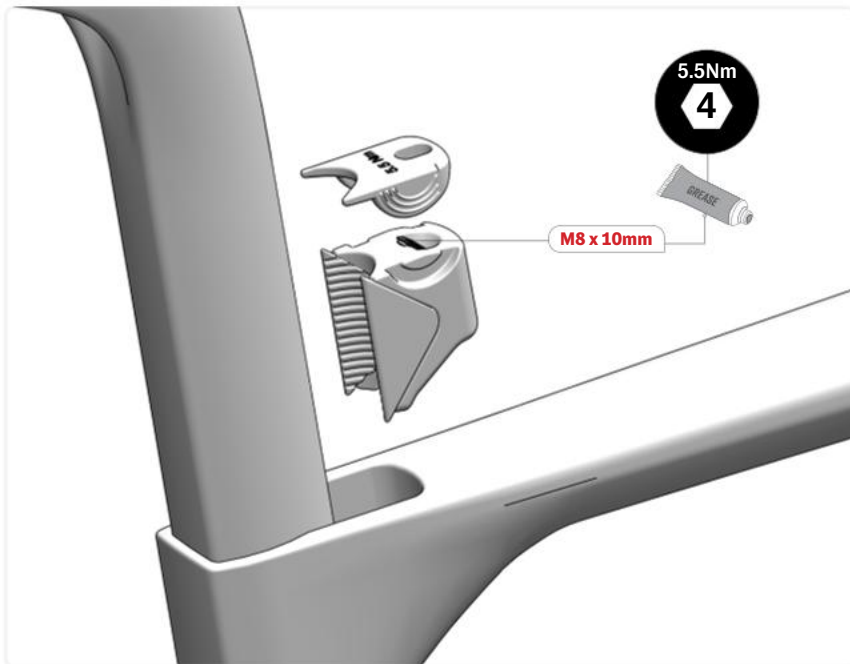
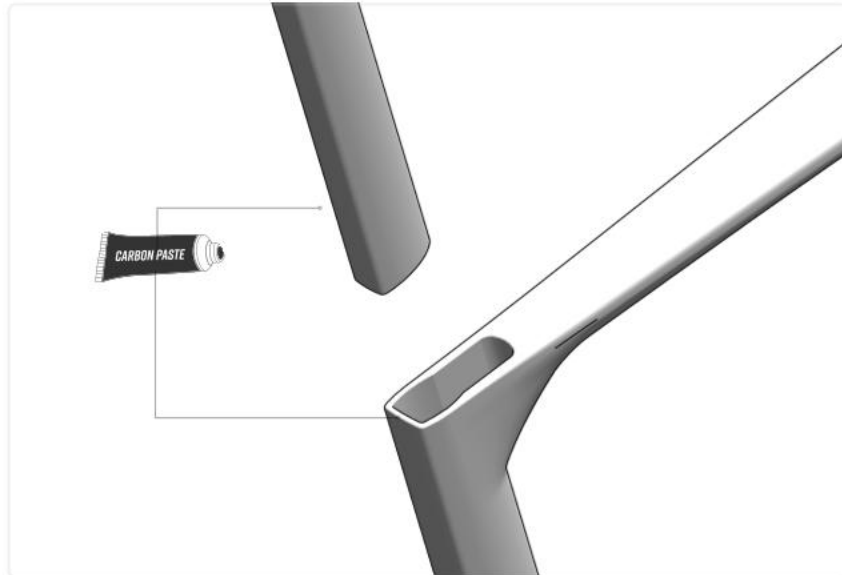

1. Apply grease on the lower angle surface of the seat post collar.
2. Apply a drop of blue Threadlocker (n. 242) on the M3 x 6mm screw thread.
3. Hand tighten the M3 x 6mm screw and make a 1/4 turn back, making sure the wedge (a) is allowed to slide.
4. Apply grease on the thread of the M8 x 10mm set screw.
5. Screw the M8 x 10mm set screw in place.
6. Slide the rubber cover onto the wedge assembly.
7. Apply carbon paste on the seatpost and seat tube cavity, then insert the seatpost and adjust at the desired height. Make sure to follow the seatpost min and max insertion. (p. 12)
8. Insert the wedge assembly into the frame.
9. Adjust the angle of the seatpost wedge cover to make it flush with the frame surface.
10. Tighten the M8 x 10mm set screw of the seat post clamp to 5.5Nm.

## 7. REAR DERAILLEUR HANGER INSTALLATION

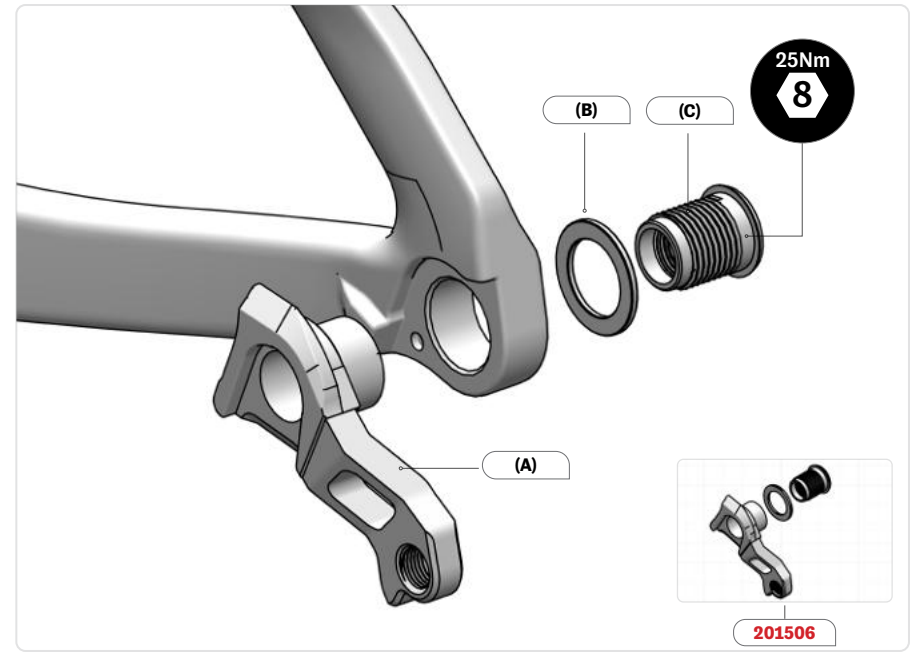
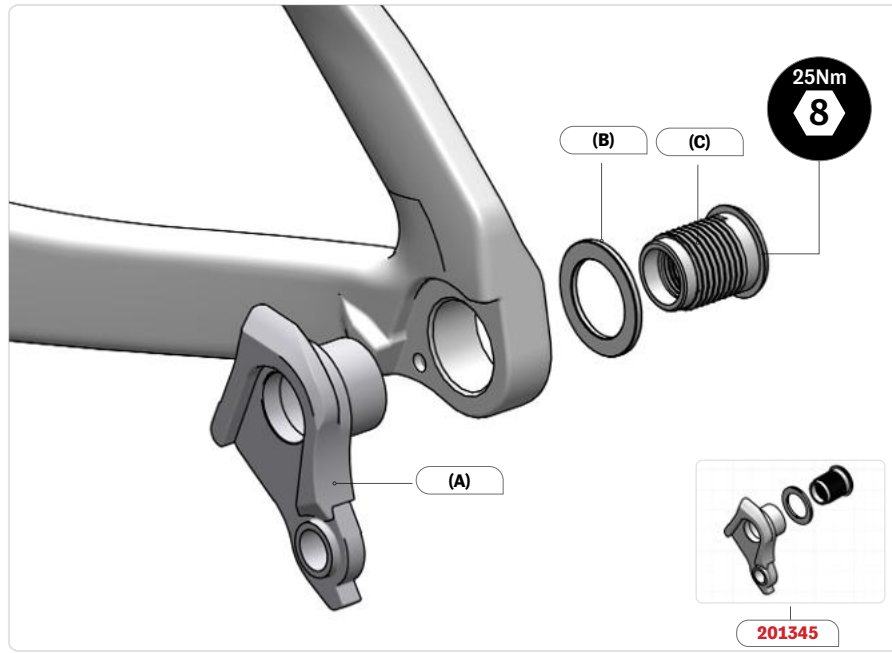

**Assembling with a Regular hanger (SKU: 201345) or Direct mount version (SKU: 201506):**

1. Install the UDH hanger (A) into the frame dropout. **Do not apply grease to the UDH hanger or bolt.**
2. Rotate the UDH hanger forward until it is completely seated in the hanger pocket and contacts the rotational stop tab.
3. Install the UDH bolt (C) through the washer (B) and into the UDH hanger threads.
4. Tighten the bolt to 25Nm of torque. **The UDH hanger bolt is left-hand threaded.**
5. Confirm the hanger has not moved after applying torque.
6. Use a rear derailleur hanger alignment gauge to align the rear derailleur hanger. (If necessary)
7. **Apply grease only to the thru axle threads.**

**The NITROGEN and NITROGEN PRO are UDH compatible (SRAM Universal Derailleur Hanger standard).**

For assistance,

visit SRAM's website at: <https://www.sram.com/en/service/models/ac-drhg-udh-a1>

visit Park Tool's website at: <https://www.parktool.com/blog/repair-help/rear-derailleur-hanger-alignment>

## 8. FRONT DERAILLEUR HANGER INSTALLATION

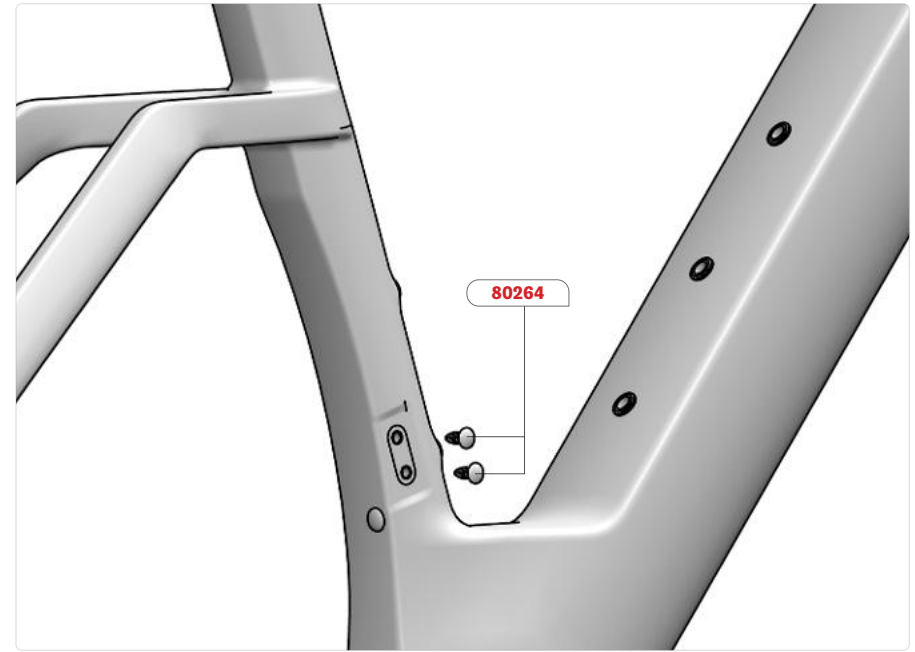

### Using a Double Chainring Set-Up:

1. Apply grease on the thread of both M5 x 16mm screws.
2. Assemble the front derailleur hanger (SKU: 81499) on the frame with the two screws.
3. Tighten the two M5x16mm screws to 3Nm.

#### Note:

The front derailleur hanger has been designed to work with 50 to 57 teeth round chainrings or oval chainrings with an equivalent max OD of a 57T round chainring.

### Using a Single Chainring Set-Up:

1. Insert plastic plugs (SKU: 80264) into the front derailleur hanger inserts.

## 9.1 FRONT BRAKE ROUTING



1. Guide the hydraulic housing through the hole in the fork's blade and pull it out from the opening in the lower section of the steerer.
2. Secure the front brake housing on the steerer using electrical tape as high as possible without interfering with the upper bearing.

## 9.2 REAR BRAKE ROUTING



1. Guide the rear brake housing starting through the hole in the Non-Drive-Side chainstay all the way up to the headset opening. Pass the housing **over** the bottom bracket shell.
2. Slide foam liners (SKU: 80811) onto the brake housing until it reach the bottom bracket shell.

## 10. FORK ASSEMBLY

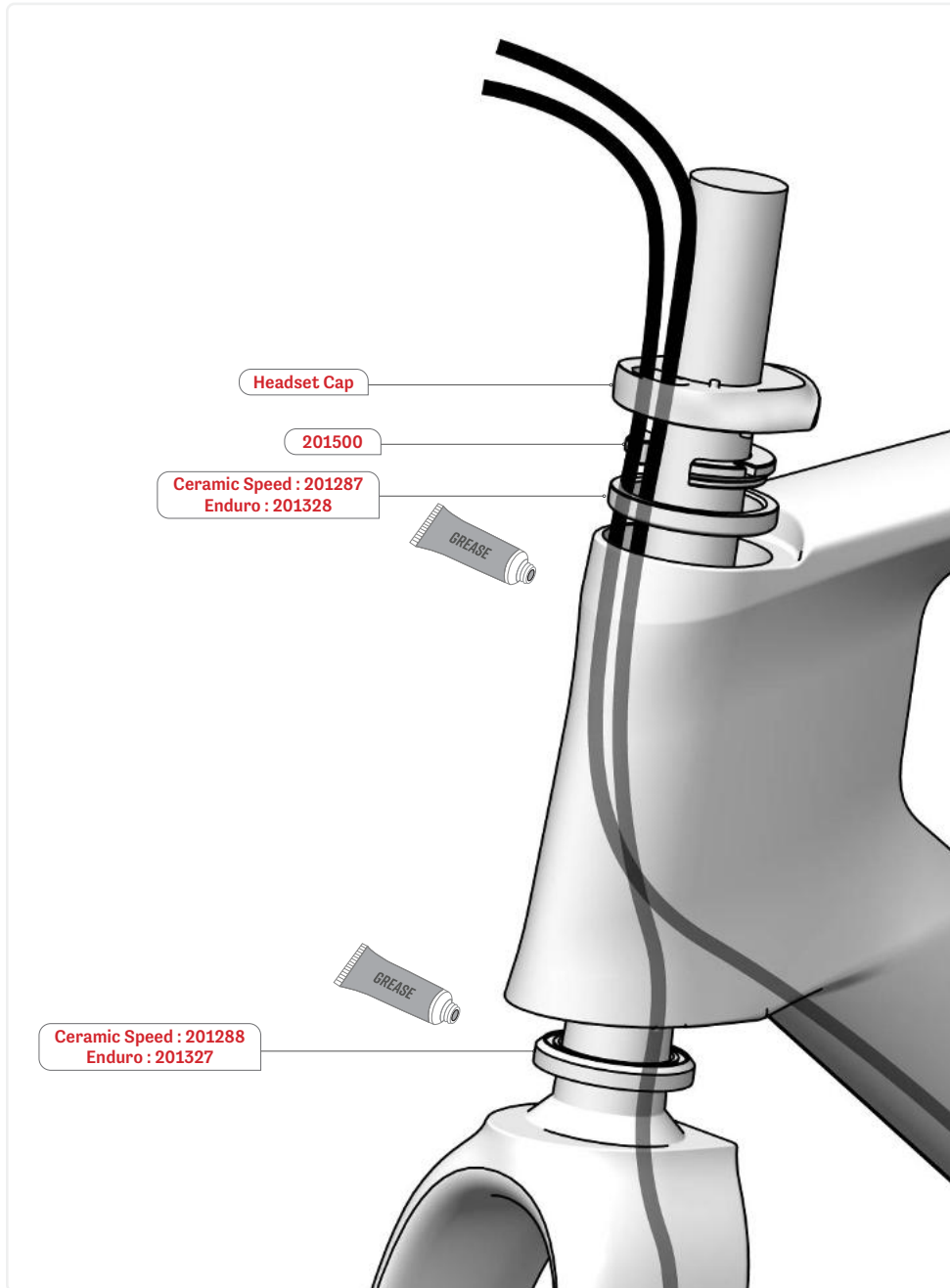

1. Apply grease onto all the bearing rest surfaces (frame & fork)
2. Insert the fork steerer and front brake housing **through** the bottom bearing.  
Nitrogen Pro : Ceramic Speed : 201288  
Nitrogen : Enduro : 201327
3. Slide the fork steerer into the frame headtube.
4. Insert the top bearing onto the steerer and into the frame. Make sure every housing pass **through** the top bearing.  
Nitrogen Pro : Ceramic Speed : 201287  
Nitrogen : Enduro : 201328
5. Insert the compression ring (SKU: 201500) onto the steerer and into the bearing
6. Choose the desired headset cap and insert it onto the steerer, aligning the pins with the compression ring.



## II. CABLE AND HOUSING ROUTING - ELECTRONIC WIRELESS

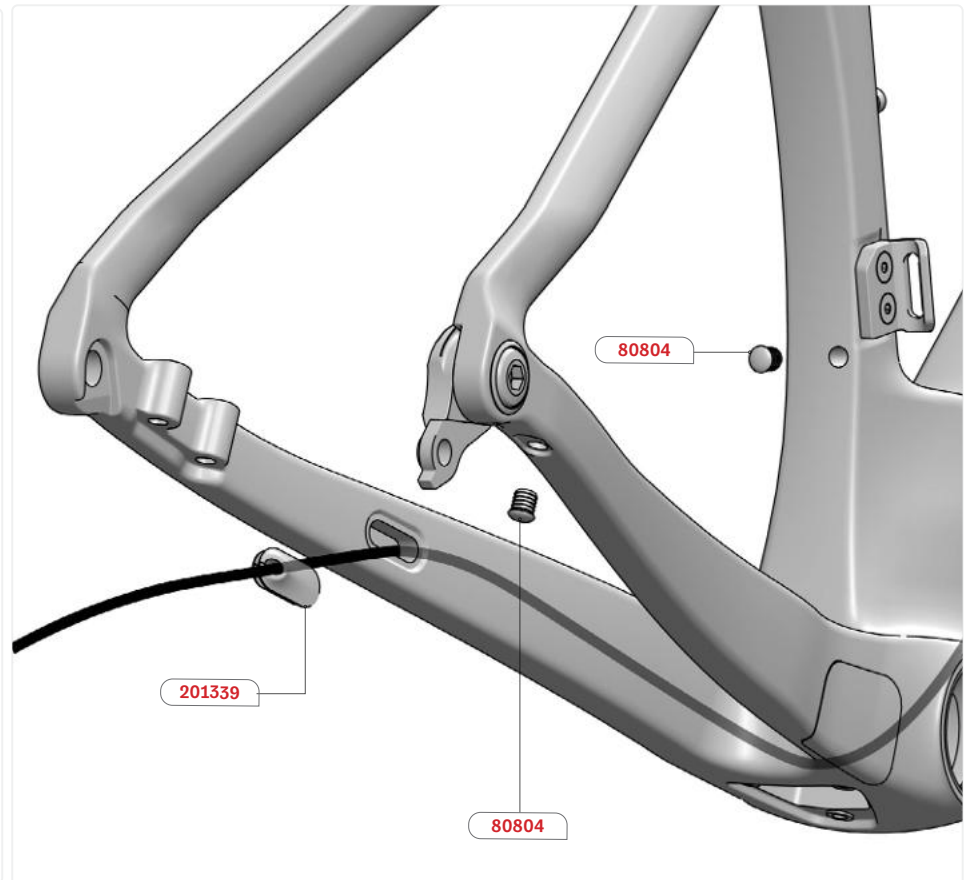

- 1.** Insert one long plug grommet (SKU: 80804) onto front derailleur cable hole on the seat tube.
- 2.** Insert one long plug grommet (SKU: 80804) onto rear derailleur cable hole on the drive side chainstay.
- 3.** Insert the rear brake oblong cable guide (SKU: 201339) onto the non-drive side chainstay hole.

## 12. CABLE AND HOUSING ROUTING - ELECTRONIC WIRED



1. Using as fishing cable\*, guide the two Di2 wires from their respective opening to the bottom bracket opening (under the frame). Pass all the wires **behind** the bottom bracket shell and let them hang out the frame by the opening.

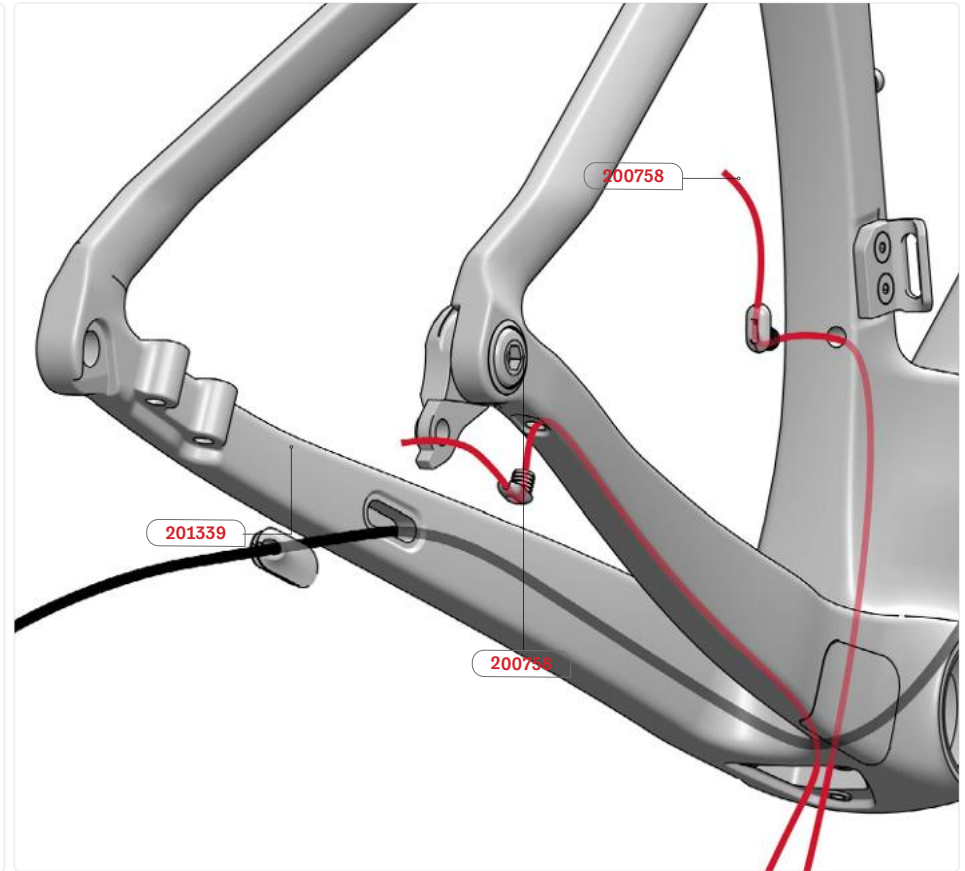

1. Insert one angled grommet Di2 (SKU: 200758) onto front derailleur cable hole on the seat tube.
2. Insert one angled grommet Di2 (SKU: 200758) onto rear derailleur cable hole on the drive side chainstay.
3. Insert the rear brake oblong cable guide (SKU: 201339) onto the non-drive side chainstay hole.

### 13. BOTTOM BRACKET COVER INSTALLATION

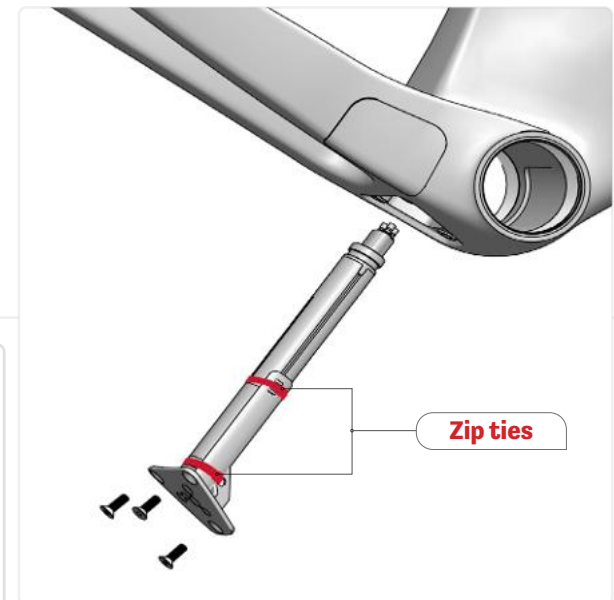

1. For Di2, install the battery on the BB Cover (SKU: 201496 for frame sizes S-M-L-XL, SKU: 201497 for frame sizes XXS-XS) using 2 zip ties and connect both Di2 cables to the battery.
2. Apply grease on the threads of the three M4 x 12mm screws.
3. Install the BB Door with the three M4 x 12mm screws.
4. Tighten all screws to 1Nm.

## 14. BOTTLE CAGES POSITIONS

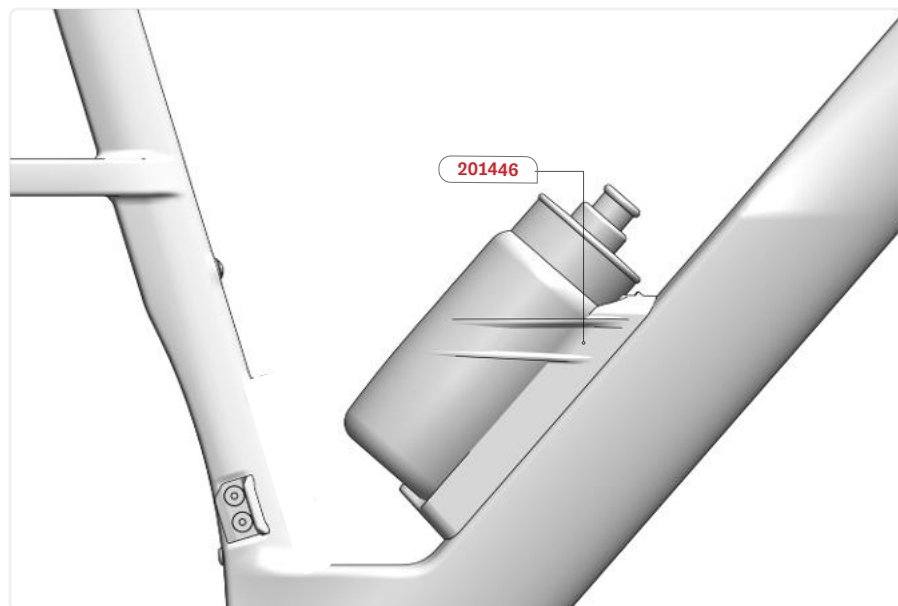

One water bottle

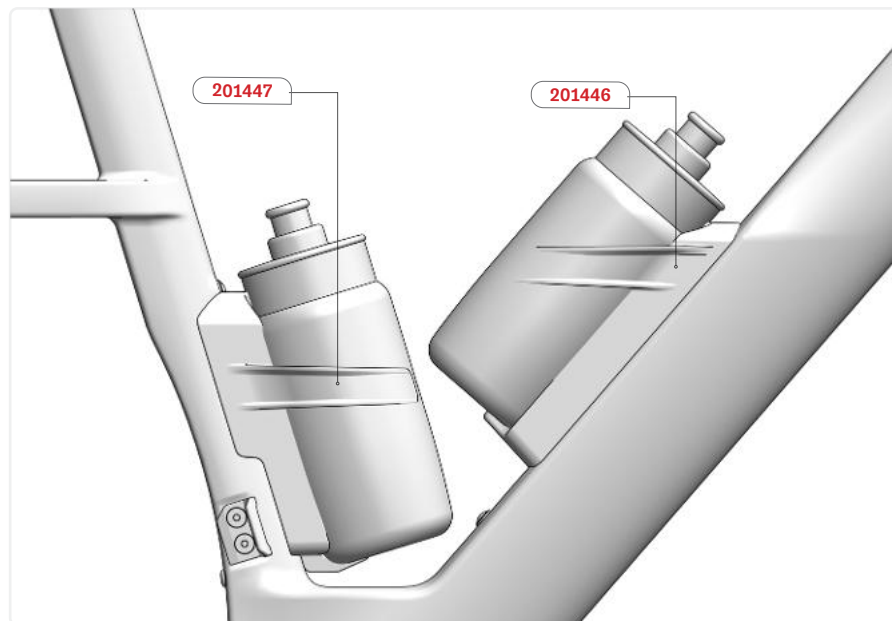

Two water bottles

- 1.** While the NITROGEN is compatible with regular water bottle cages, it comes equipped with custom, integrated water bottle cages optimized for aerodynamics.
- 2.** The DownTube Aero Bottle Cage (SKU: 201446) can be positioned in the lower position to lower the mass center, or in the higher position to ease the bottle access.
- 3.** The SeatTube Aero Bottle Cage (SKU: 201447) is designed to be aerodynamic with or without a water bottle. On Large and X-Large Frame sizes, the seat tube water bottle cage can be placed higher to ease the bottle access.\*

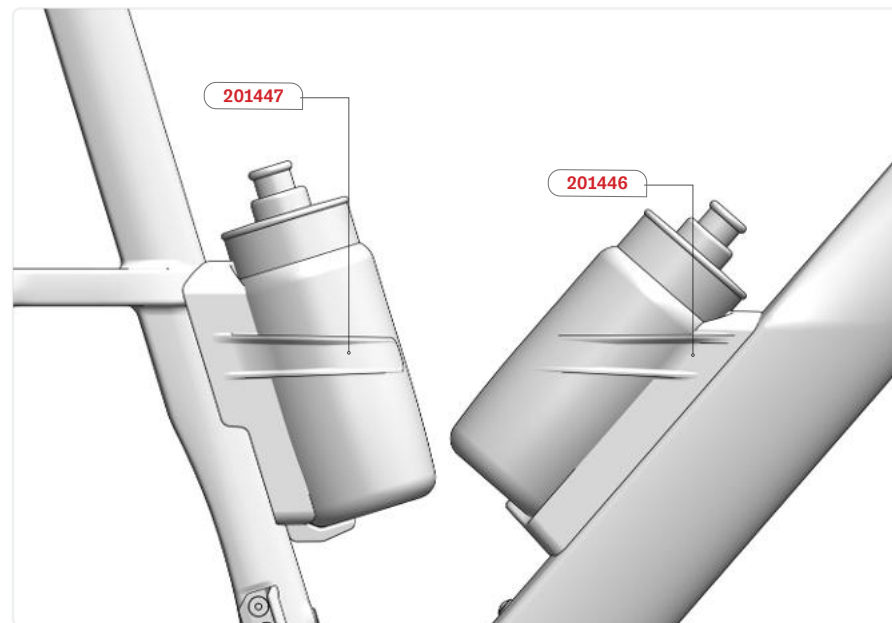

\* Only for Large and X-Large Frame sizes

# ATTEN

## CHB-1 AERO



VALID FOR ATTEN CHB-1 AERO

## 15. HANDLEBAR SPECIFICATIONS

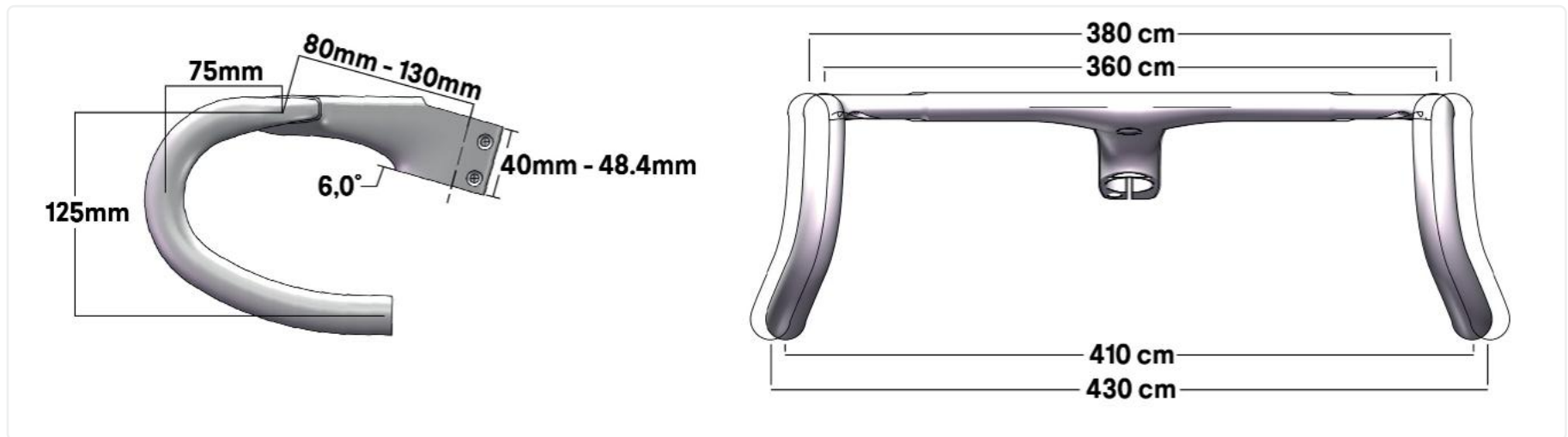

Choosing the right Aero Handlebar:

The Nitrogen comes equipped with an ATTEN Aero handlebar, there are multiple sizes available, make sure you have the one corresponding to your fit.

Here is the list of all sizes available:

### 360mm

- 201301 - ATTEN Aero Handlebar 360 x 80mm
- 201302 - ATTEN Aero Handlebar 360 x 90mm
- 201303 - ATTEN Aero Handlebar 360 x 100mm
- 201304 - ATTEN Aero Handlebar 360 x 110mm
- 201305 - ATTEN Aero Handlebar 360 x 120mm
- 201532 - ATTEN Aero Handlebar 360 x 130mm

### 380mm

- 201531 - ATTEN Aero Handlebar 380 x 80mm
- 201306 - ATTEN Aero Handlebar 380 x 90mm
- 201307 - ATTEN Aero Handlebar 380 x 100mm
- 201308 - ATTEN Aero Handlebar 380 x 110mm
- 201309 - ATTEN Aero Handlebar 380 x 120mm
- 201310 - ATTEN Aero Handlebar 380 x 130mm

## 16.1 HANDLEBAR PARTS



201301 (360 x 80)  
 201302 (360 x 90)  
 201303 (360 x 100)  
 201304 (360 x 110)  
 201305 (360 x 120)  
 201532 (360 x 130)

201531 (380 x 80)  
 201306 (380 x 90)  
 201307 (380 x 100)  
 201308 (380 x 110)  
 201309 (380 x 120)  
 201310 (380 x 130)



201503

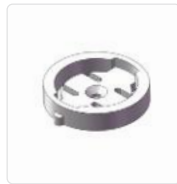

201504



201505

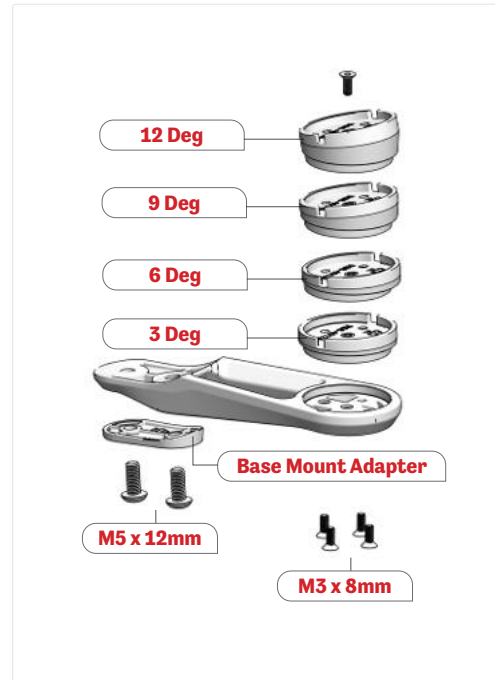

201502

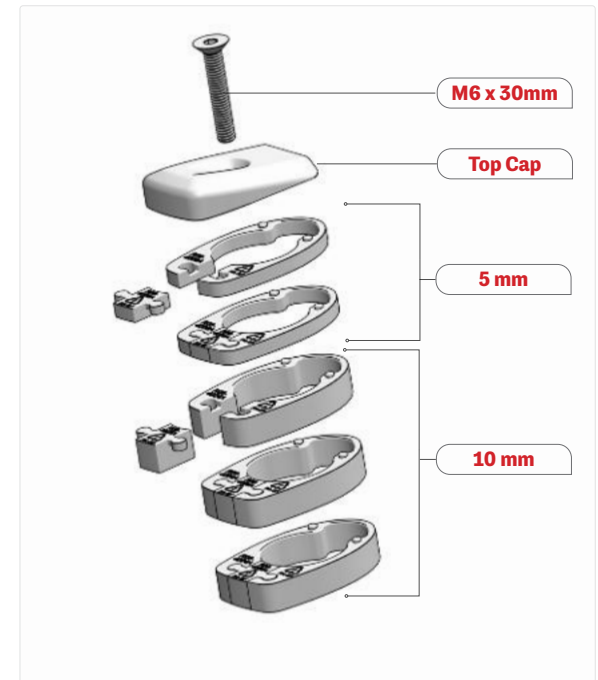

201501

## 16.2 HANDLEBAR SKUS & DESCRIPTIONS

NO.	NAME	A18 SKU#	QTY
1	ATTEN CHB-1 AERO 360x80mm	201301	1
	ATTEN CHB-1 AERO 360x90mm	201302	
	ATTEN CHB-1 AERO 360x100mm	201303	
	ATTEN CHB-1 AERO 360x110mm	201304	
	ATTEN CHB-1 AERO 360x120mm	201305	
	ATTEN CHB-1 AERO 360x130mm	201532	
	ATTEN CHB-1 AERO 380x80mm	201531	
	ATTEN CHB-1 AERO 380x90mm	201306	
	ATTEN CHB-1 AERO 380x100mm	201307	
	ATTEN CHB-1 AERO 380x110mm	201308	
	ATTEN CHB-1 AERO 380x120mm	201309	
ATTEN CHB-1 AERO 380x130mm	201310		
2	ATTEN CHB-1 AERO - HARDWARE	201499	1 kit
3	ATTEN CHB-1 AERO - SMALL PARTS		
4	ATTEN CHB-1 - HEADSET SPACER 10mm		
5	ATTEN CHB-1 - SPACER 10mm CLOSING CLIP		
6	ATTEN CHB-1 - HEADSET SPACER 5mm	201501	1 kit
7	ATTEN CHB-1 - SPACER 5mm CLOSING CLIP		
8	ATTEN CHB-1 - STEM CAP		
9	STEM CAP SCREW - FHCS_ M6x35		
10	COMPUTER MOUNT ASSY - ATTEN CHB-1 AERO		
11	ATTEN CHB-1 - COMPUTER MOUNT DEDICATED		
12	ATTEN CHB-1 - MOUNT ADAPTER ANGLED 3 DEG.		
13	ATTEN CHB-1 - MOUNT ADAPTER ANGLED 6 DEG.		
14	ATTEN CHB-1 - MOUNT ADAPTER ANGLED 9 DEG.	201502	1 kit
15	ATTEN CHB-1 - MOUNT ADAPTER ANGLED 12 DEG.		
16	ATTEN CHB-1 - COMPUTER MOUNT BASE ADAPTER		
17	BUTTON HEAD CAP SCREW - M5x 0.8 x 12 LG		
18	FHCS_M3x8		
19	GARMIN Edge Tray	201503	1
20	WAHOO ELEMNT Tray	201504	1
21	GoPro Tray	201505	1

## 17.1 HANDLEBAR INSTALLATION

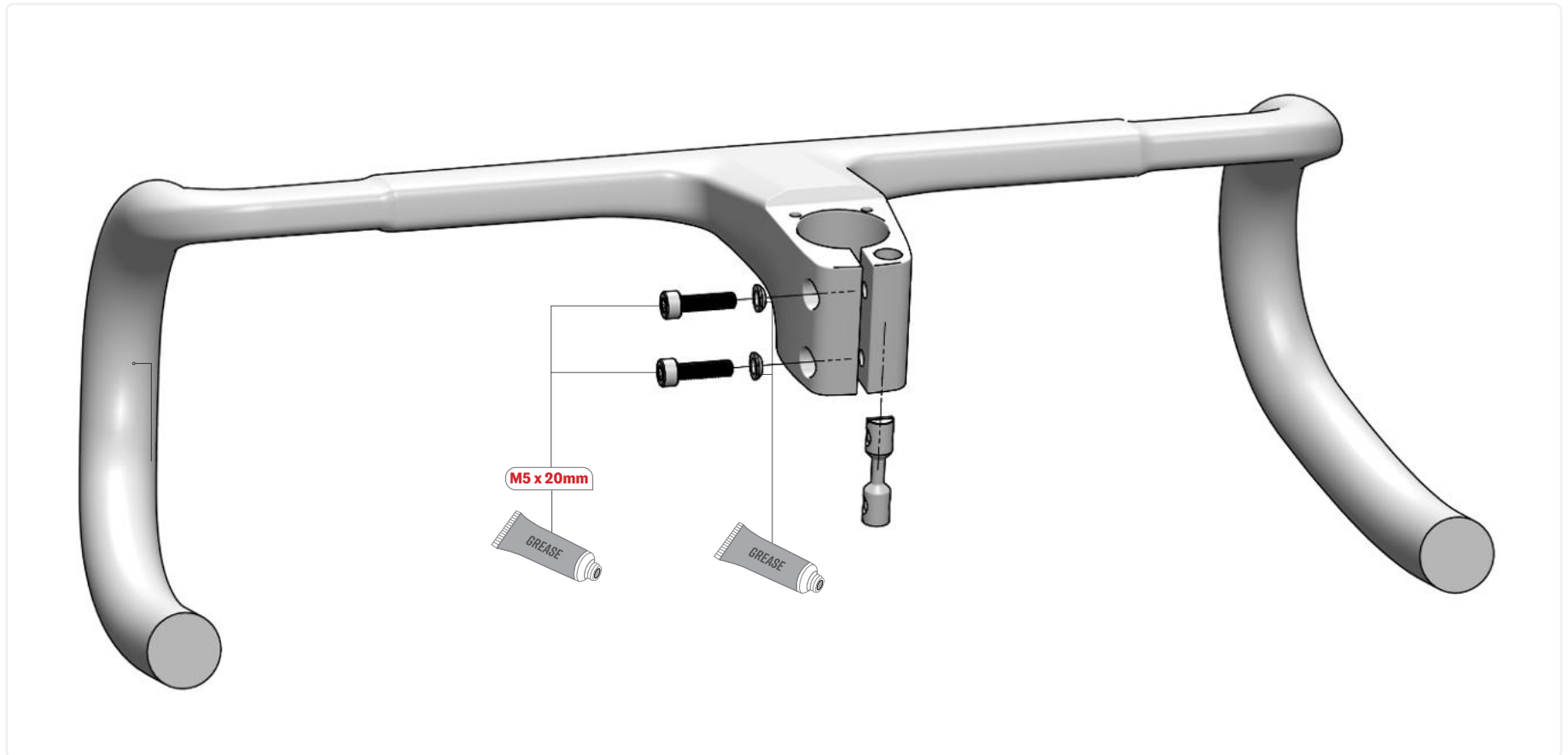

### Installing the Aero Handlebar:

1. Apply grease on the threads of each M5 x 20mm screw and on the spherical washer.
2. Install the stem barrel in the designed hole while aligning the thread with the screw.
3. Pre-assemble both M5 x 20mm screws in place.



### IMPORTANT:

Failure to follow these practices will automatically void any warranty claim against the manufacturer.

## 17.2 HANDLEBAR INSTALLATION



### IMPORTANT:

Failure to follow these practices will automatically void any warranty claim against the manufacturer.

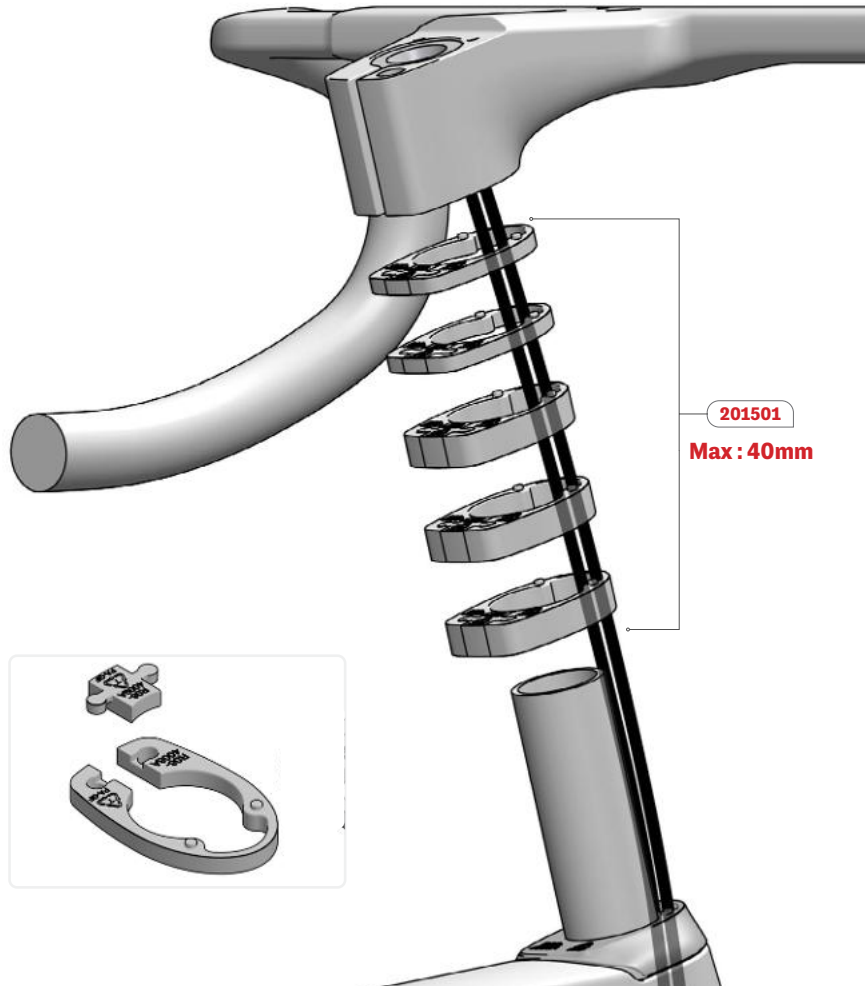

Stem height vary depending on the length of stem to keep an angle of -6 degree.

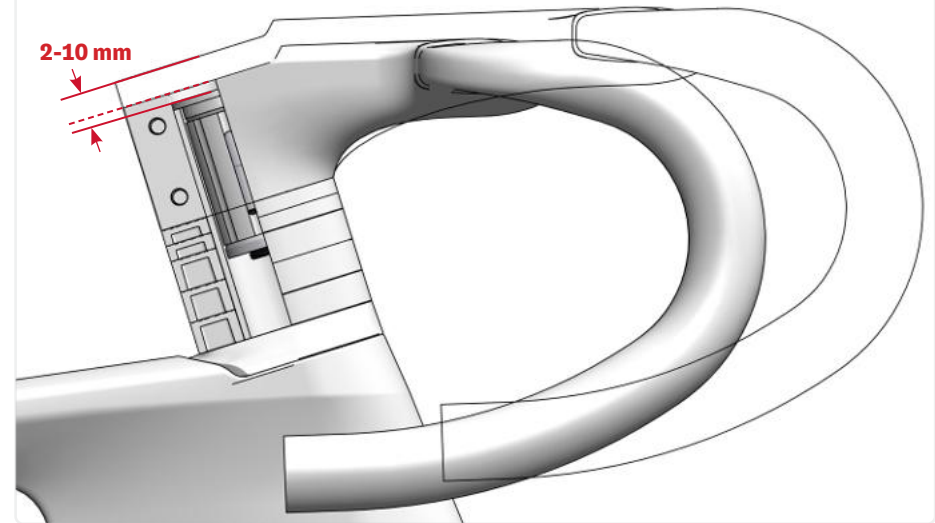

### Cutting the steerer:

1. Select the amount of spacer needed (SKU: 201501), up to 40mm can be installed under the handlebar.
2. Spacer are designed in 2 parts to allow removing or adding spacer without cutting the brake housing. Assembly is like a puzzle, make sure the spacer is assembled correctly.
3. Cut the steerer 36mm over the last spacer. This will enable the possibility to change handlebar size without recutting the steerer.
4. Apply carbon paste between compression plug and steerer. Install the compression plug flush with the steerer. Tighten expander plug to 10-15Nm.
5. The top of the compression plug should be 2 to 10mm below the top of the handlebar depending on the stem length on the handlebar. This will ensure proper compression of the headset.

### Important:

- No spacers can be placed between the stem and the top cap of the headset.

## 17.3 HANDLEBAR INSTALLATION

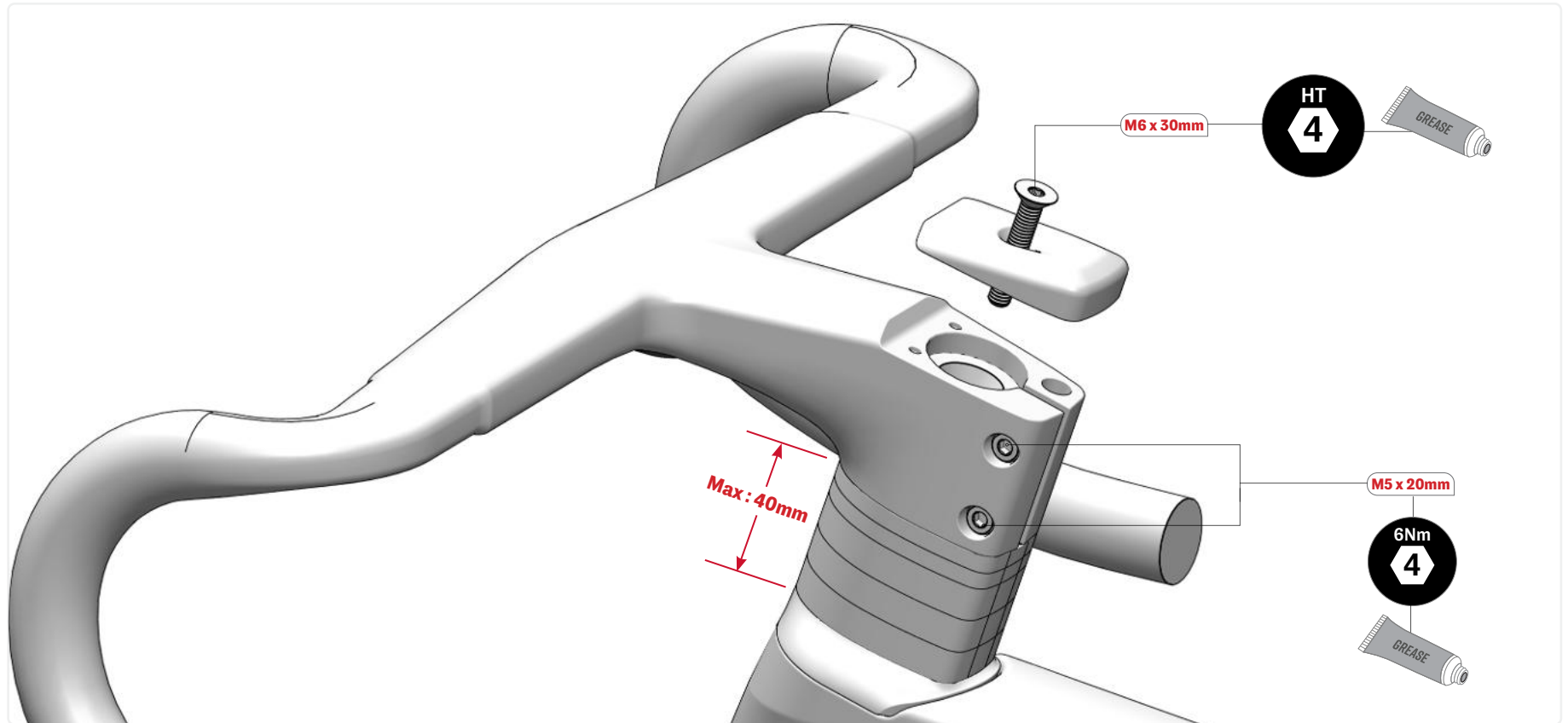

1. Tighten the compression screw (M6 x 30mm) until there's no play in the headset bearing. Make sure there's at least 2 mm of gap to allow headset adjustment.
2. Align the stem and torque the M5 x 20mm screw to 6Nm.
3. Install the lever in the textured zone and torque to the manufacturer recommended torque

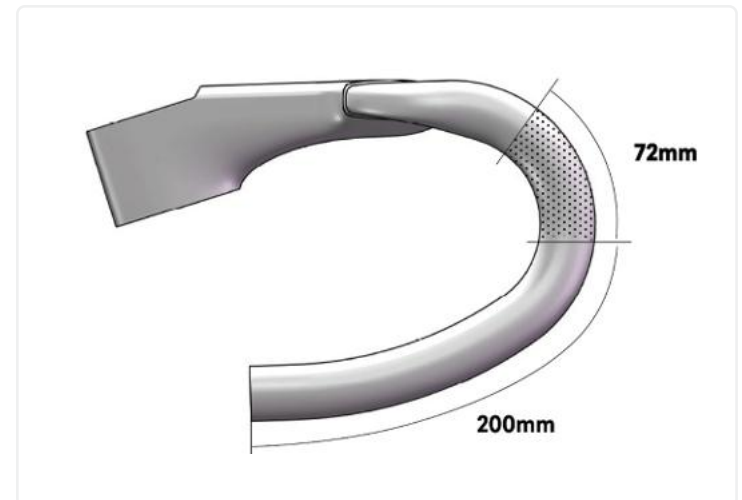

## 18.1 COMPUTER MOUNT INSTALLATION

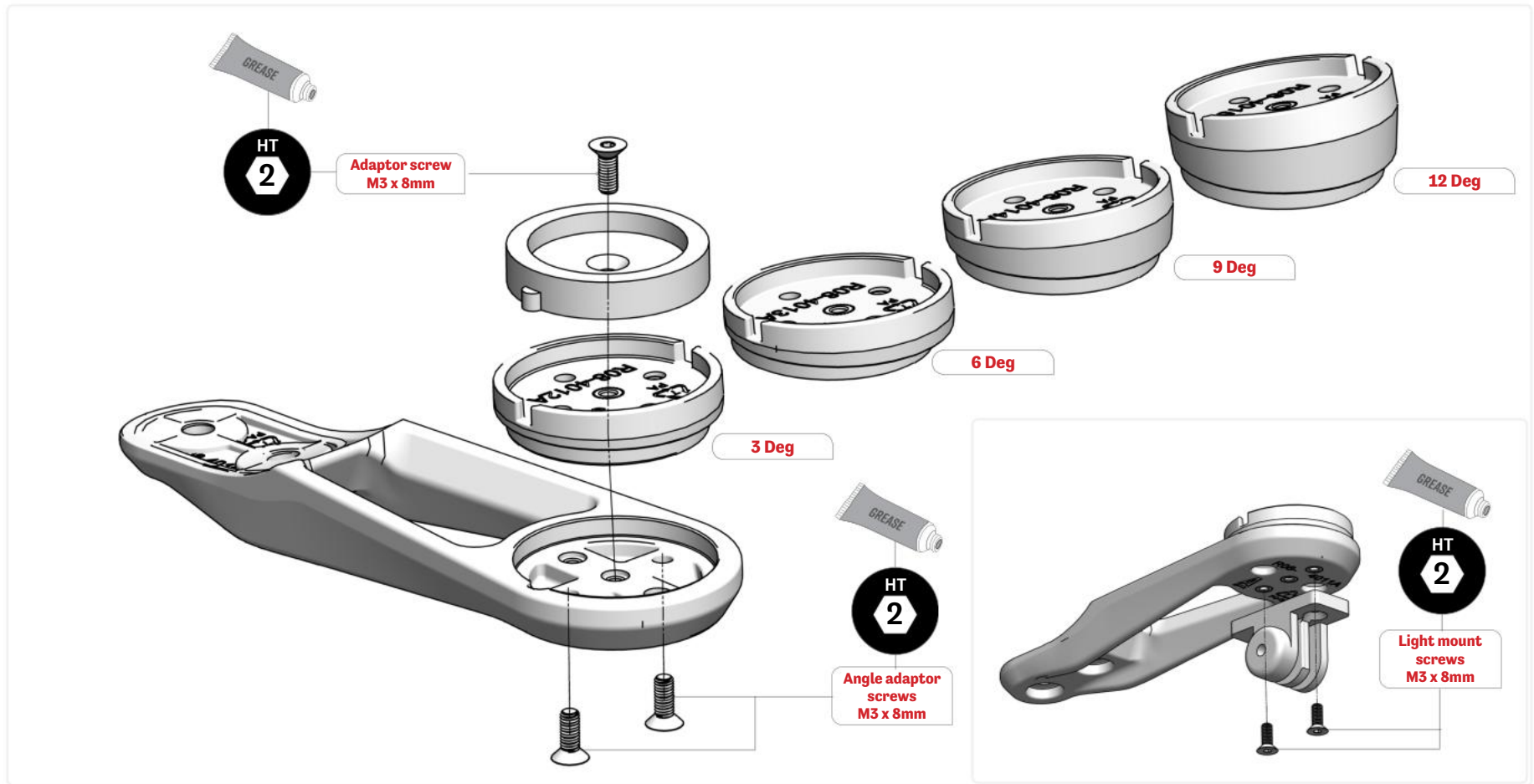

### Assembling the computer mount with an angle adaptor:

1. Choose the desired angle adaptor.
2. Apply grease on the threads of both M3 x 8mm screws.
3. Handtighten both screws from under the computer mount.
4. Follow 0deg installation step.

### Assembling the computer mount at 0deg:

1. Choose the correct adaptor, Garmin or Wahoo.
2. Apply grease on the threads of the M3 x 8mm screw.
3. Handtighten the screw.

### Assembling the light/camera mount:

1. Apply grease on the threads of both M3 x 8mm screws.
2. Handtighten both screws from under the computer mount.

## 18.2 COMPUTER MOUNT INSTALLATION

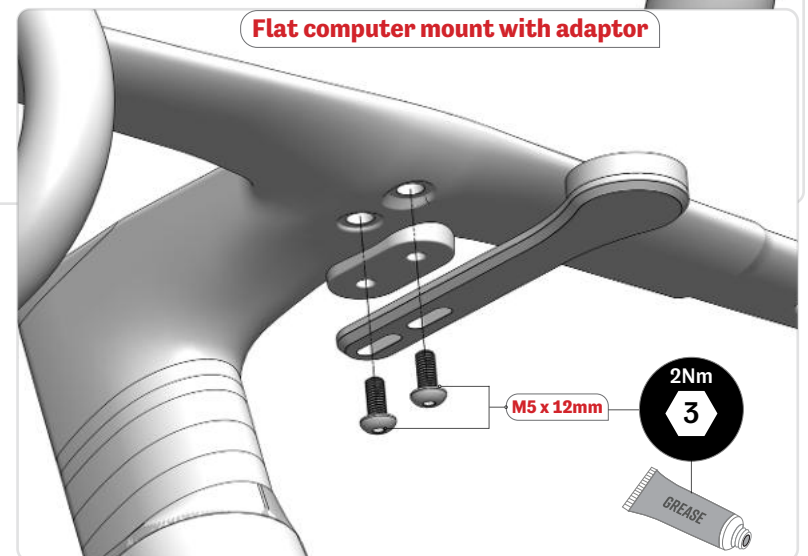
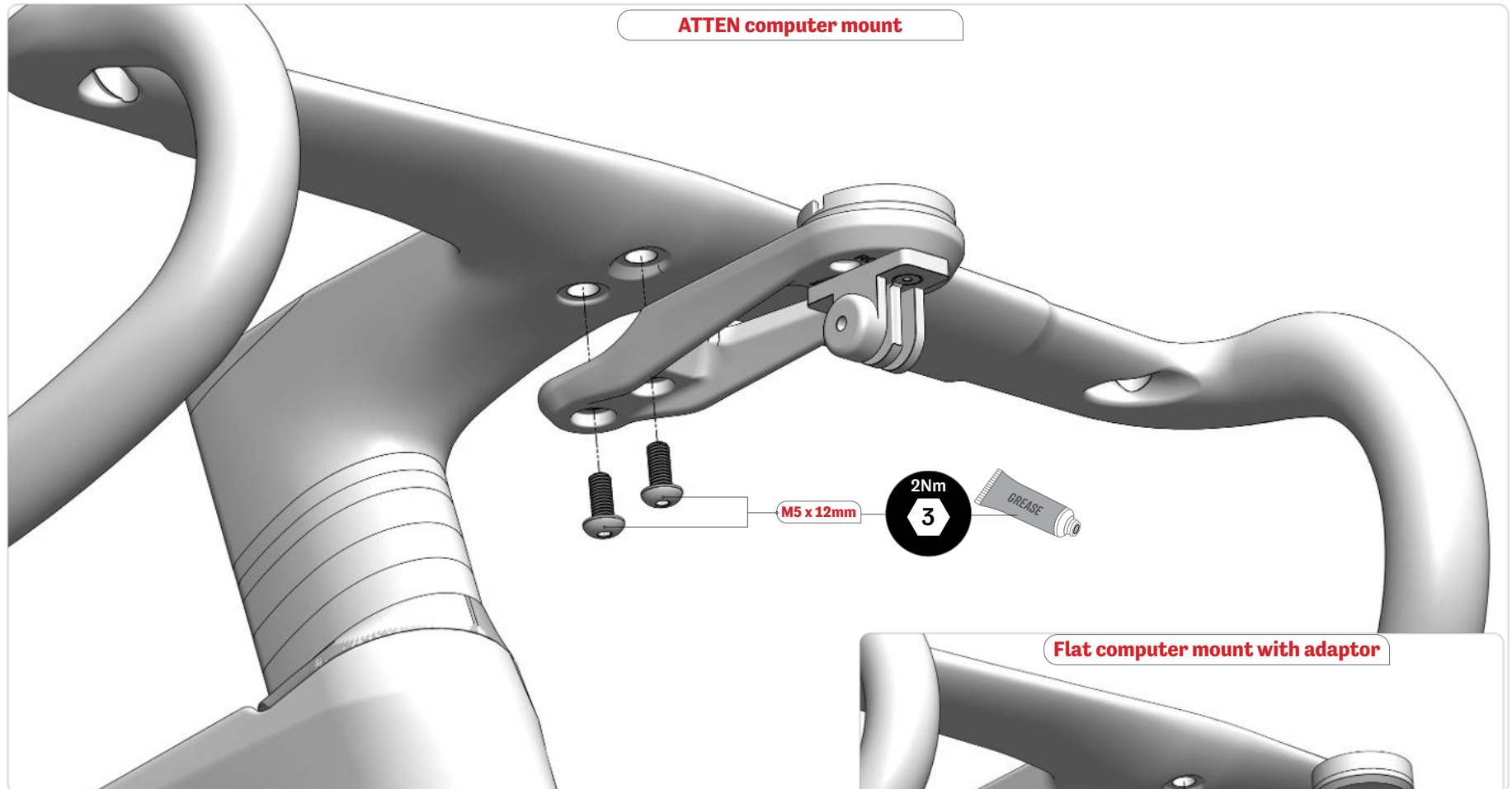

### Installing the computer mount:

1. Choose whether you want to install the ATTEN computer mount or a flat computer mount using the supplied adaptor.
2. Apply grease on the threads of each M5 x 12mm screw.
3. Install the computer mount in place and tighten both M5 x 12mm screw to 2Nm.

## 19. HANDLEBAR INSTALLATION (NON-INTEGRATED)

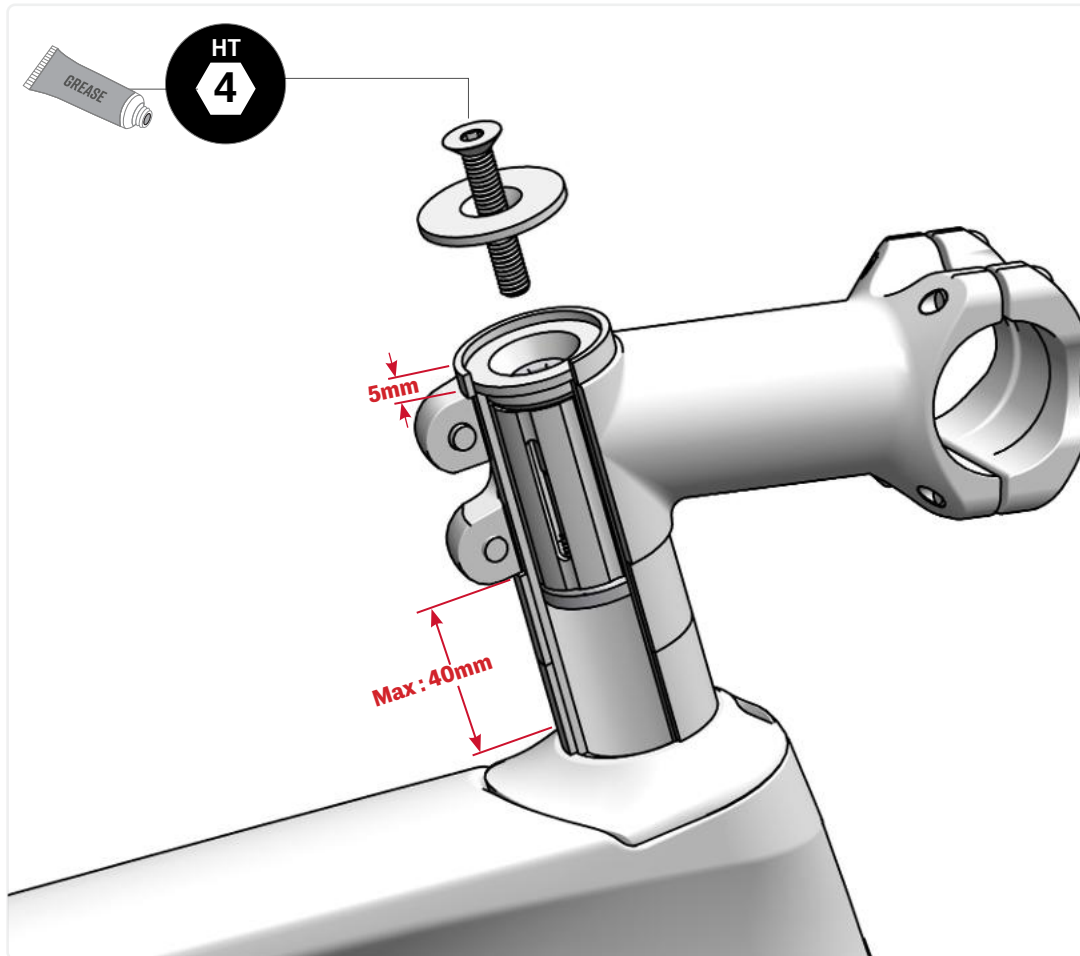

### IMPORTANT:

Failure to follow these practices will automatically void any warranty claim against the manufacturer.

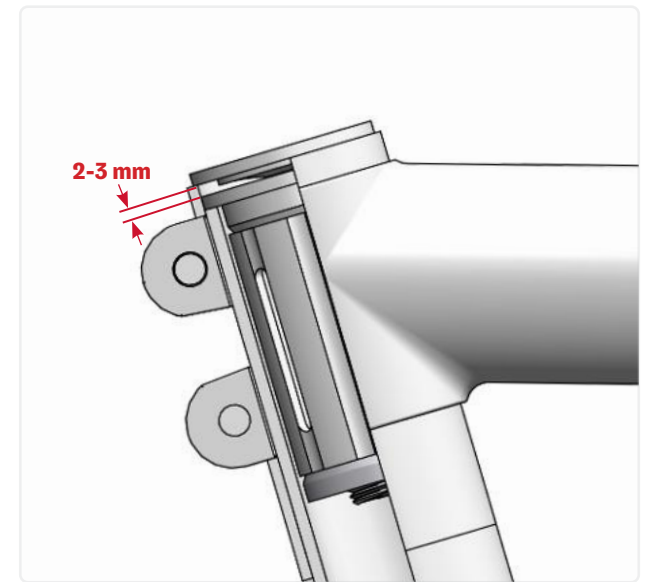

### Installing regular stem:

1. Cut the steerer so a 5mm spacer can be used on top of the stem. This will ensure the stem clamping area is fully supported by the carbon steerer.
2. Apply carbon paste between compression plug and steerer. Tighten expander plug to 10-15Nm.
3. Tighten the compression screw until there's no play in the headset bearing. Make sure there's 2 to 3 mm of gap to allow headset adjustment.
4. Align the stem and torque the bolts to the manufacturer recommended torque.

### Important:

- No more than 40mm of spacers can be placed between the stem and the top cap of the Headset.
- It is critical to assemble the headset expander plug at the same height as the stem's steerer clamp.