

# Speedmachine

Owners Manual

***BMC***

# Table of content

<b>Introduction</b>	<b>5</b>
<b>Generalities</b>	<b>5</b>
General notes and warnings	5
Intended use	6
Bike registration and warranty extension	6
<b>Before we start</b>	<b>7</b>
Components compatibility chart	7
Special parts details	8
General notes about assembly	17
Repair stand	17
Torque specifications	18
Recommended assembly procedure	19
<b>Sizing and parts selection</b>	<b>20</b>
Positioning	20
Frame size	20
Armrest fitting ranges	21
<b>Detailed assembly instructions</b>	<b>23</b>
Frame preparation	23
Fork preparation	25
Base bar preparation	25
Seatpost preparation	26
Electronic wires installation	27
Seatpost assembly	29
Brake calipers assembly	31
Headset and fork assembly	35
Bottom bracket and crankset assembly	36
Base bar assembly	37
Armrest risers, armrests and extensions assembly	40
FuelTank installation	48
Water bottle installation	50
Top tube storage	51
Wheels and axles	52
<b>Service instructions</b>	<b>53</b>
Washing your bike	53
After washing	53
Trouble shooting	53

# Introduction

The Speedmachine represents the pinnacle of functional integration, aerodynamic form and rider-focused fit. By patiently following these guidelines, the content of this manual will lead to properly fitting and functioning equipment with a high-performance, Swiss Engineered aesthetic.

BMC Speedmachine frame and components are designed as a system to provide a very high level of aerodynamics and riding performance. Adjustability was not in any way compromised and the Speedmachine offers the highest adjustment possibility ever built into a fully integrated triathlon or time trial bicycle.

Adjustability being a key part of the system's performance, it is necessary to understand that most components of the frameset have been designed specifically for Speedmachine and their function may slightly differ from your traditional road bike "off the shelf" components.

BMC Speedmachine uses all the latest and most high-end technologies that can be found in bicycle manufacturing, including sharp edged and thin-walled carbon fiber composite construction, which should be treated with delicacy from the end user to prevent permanent and sometimes invisible damage.

For the reasons mentioned above, we ask you to carefully follow the instructions provided in this manual.

Incorrect mechanical operation on your bicycle could lead to serious damage, which could cause you to fall and lead to injury or death.

If you do not have the appropriate tools or experience to execute the following instructions, or if you need further information, please contact your official BMC dealer for service of your bicycle.

## Generalities







### General notes and warnings

You must read and understand the Safety Instructions described into BMC Owner's Manual included with your product before proceeding with installation. Improperly installed components are extremely dangerous and could result in severe and/or fatal injuries. If you have any questions about the installation of these components, consult a qualified bicycle mechanic.

 **WARNING:** Indicates a dangerous or hazardous situation. Not respecting the instruction could result in losing control of the bike or having a component fail. Consequences could be: product damage, injury or death.

 **INFORMATION:** Indicates an important information.

This manual uses icons and color codes to indicate actions for proper assembly and adjustments.

 Grease	 Torque
 Thread locker	 Adjust
 Friction Paste	 Measure

## Intended use

The Speedmachine is designed and tested for Road riding only and complies to Level 1 ASTM Classification.

Please read and refer to the general BMC Owner's Manual for more details.

The structural weight limit for the Speedmachine is 110kg / 242lb

**⚠ WARNING:** Always make sure to never exceed the structural weight limit with the sum of rider weight, ride's equipment (e.g., helmet, shoes, apparel) and nutrition (e.g., water, energy gels and bars).

Exceeding the structural weight limit may impair the structural integrity of the bike and result in component damage or failure.

## Bike registration and warranty extension

BMC provides a voluntary warranty on the frame, and on BMC components and paintwork. By registering your Speedmachine within the first six months after initial purchase on the Bike Registration page ([www.bmc-switzerland.com/bmc-bike-reg](http://www.bmc-switzerland.com/bmc-bike-reg)) or within the BMC Companion App, you can extend the warranty on the frame to five years. You can read the warranty provisions in detail on the Warranty policy page ([www.bmc-switzerland.com/warranty](http://www.bmc-switzerland.com/warranty)).

## Before we start

A Speedmachine frameset or complete bike includes proprietary components such as base bar, brake adapter, fork, headset, stem, seat post ... For each of those components, you will find part numbers, service and assembly instructions detailed in the next chapters of this manual.

## Components compatibility chart

### Brakes:

- Front flat mount for 160mm rotor only using BMC specific front brake adapter.
- Rear: flat mount brake boss 25mm thickness, compatible with Ø140mm / Ø160mm rotor
- For more details, please refer to "Brake calipers assembly", page 31.

### Headset bearings:

- Upper bearing: Enduro Bearing ACB 4545 1125T SS-bx
- Lower bearing: Enduro Bearing ACB 4545 125L SS
- For more details, please refer to "Headset and fork assembly", page 35

### Thru-axes:

- Front: BMC model CTS1048 12x100mm
- Rear: BMC model CTS1049 12x142mm

### Shifting compatibility:

- SHIMANO Di2, SRAM AXS
- Not compatible with CAMPAGNOLO EPS
- Not compatible with mechanical shifting systems
- For more details, please refer to "Electronic wires installation", page 27

### Tires:

- Knob-less/slick tires only
- Optimized for 700x28c (28mm measured)
- Max 700x30c (30mm measured)

### Crankset and chainrings:

- Bottom bracket T47 x 68mm
- Cranksets either 1x (single) or 2x (double)
- Max chainring size (2x): SRAM 59, SHIMANO 60. For more details, please refer to "Front derailleur hanger installation", page 24

### Rack:

- No rack is compatible with the Speedmachine. We know that's too bad ...

### Fenders:

- Some fenders with light fastening systems could be fitted onto the Speedmachine (SKS Speedrocker or RaceBlades).

## Special parts details

### Frameset and parts

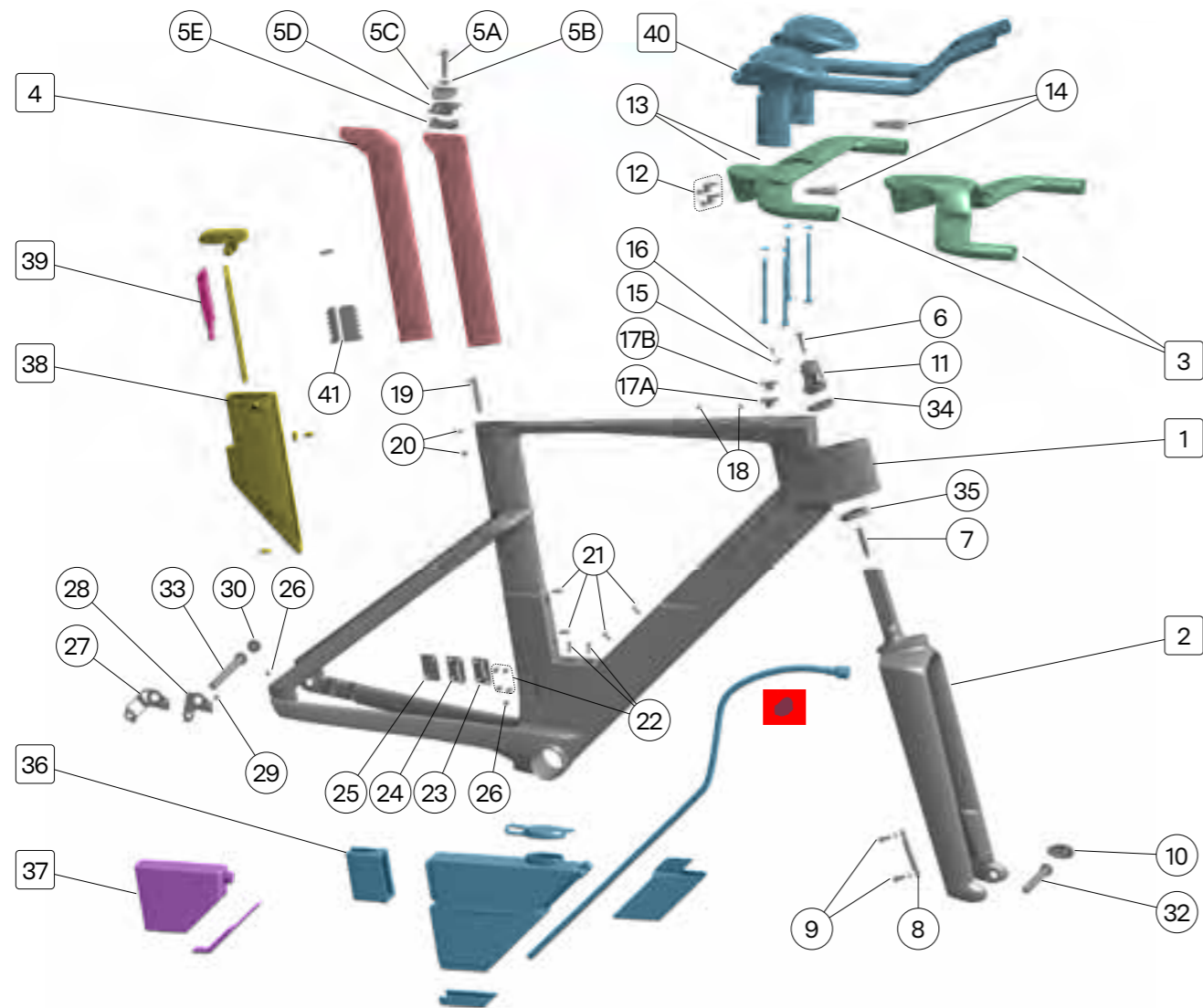

NO.	Description/Details	NO.	Description/Details
1	Speedmachine frame	19	Seatpost clamp plate
2	Speedmachine fork	20	Seat post clamp bolts M6x10
3	Speedmachine base bar	21	Bottle cages bolts M5x12
4	Speedmachine seatpost	22	Front derailleur or FuelTank bolts M4 x 16
5A	Saddle clamp Flange bolt M8x35	23	Front derailleur plate - high
5B	Saddle clamp Washer	24	Front derailleur plate - standard
5C	Saddle clamp Upper clamp	25	Front derailleur plate - cover
5D	Saddle clamp Lower clamp	26	Derailleur cable hole Blind plug 6mm
5E	Saddle clamp Clamp support	27	Rear derailleur hanger - Shimano Direct Mount
6	Headset compression aluminum bolt M6x50	28	Rear derailleur hanger - standard (SRAM)
7	Expander self-cutting aluminum bolt	29	Rear derailleur hanger bolt M4x8
8	Front brake mount adapter	30	Thru-axle rubber cover rear (TPU)
9	Front brake bolts M5x14 with washer	31	Derailleur cable plug 6mm for DI2
10	Thru-axle rubber cover front (TPU)	32	Thru-axle front
11	Headset aluminum sleeve	33	Thru-axle rear
12	Cockpit Assembly bolts M5x16.5 with washer	34	Headset upper bearing
13	Base bar top bolts M3x5	35	Headset lower bearing
14	Hand Stopper	36	FuelTank 1200
15	Rotation stop Stainless steel	37	Time Trial Bottle 400
16	Rotation stop bolt M4 x 10	38	Rear Storage 260
17A	Hydration tube cover	39	BMC Rear light StVZO
17B	Hydration tube cover - closed	40	Profile Design Risers, Armrests and extensions
18	Rivet Plug M5 (Top tube & seat tube rear)	41	Battery holder set

## Frame hardware

### Front brake adapter



**Article numbers:**  
30000714 BRK Mount ADP SLR01 SLR

### Front dropout hangers



**Article numbers:**  
30006301 FD Hanger SM00/01

### Rear dropout hangers

Standard



Direct mount



**Article numbers:**  
30006287 Dropout No. 81 (standard)      30006288 Dropout No. 82 (direct mount)

### Thru-axes

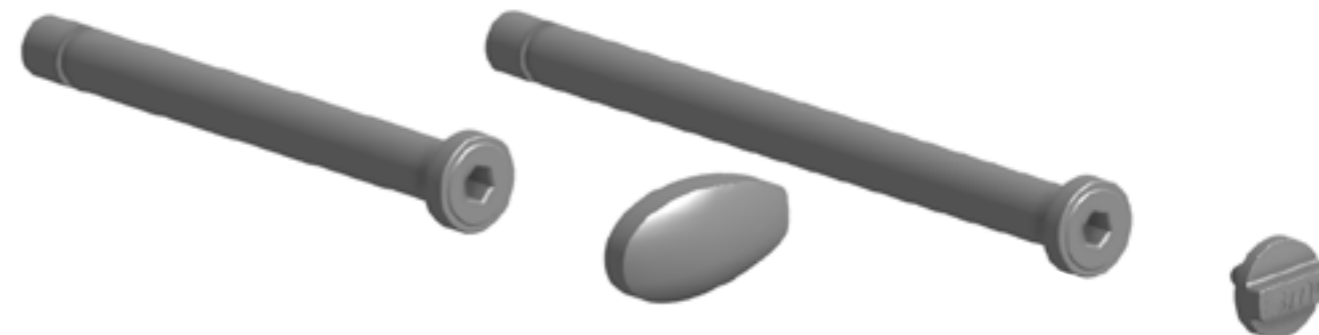

**Article numbers:**  
30006250 Thru Axle Kit No. 10  
30006292 Thru-axle plugs and Top Tube Hydration tube cover SM00/01

**Base bar**

**Base bar Flat**

The standard base bar delivered on Speedmachine is the “flat base bar”.  
Width : 400mm



**Article numbers:**

- 30006136 CKP BASE 24-R6, 0, FLAT-400, RED
- 30006138 CKP BASE 24-R6, 0, FLAT-400, CBN

**Base bar Low**

The optional “low base bar” provides a lower stack and a longer reach

Width: 400mm

Armrest:

- Stack: -32.8mm
- Reach : +35mm

Grips:

- Stack: -42.5mm
- Reach: 0mm



**Article numbers:**

- 30006135 CKP BASE 24-R6, 0, LOW-400, CBN
- 30006137 CKP BASE 24-R6, 0, LOW-400, RED

**Headset bearings**

**Article numbers:**

- 30006294 Headset Bearings SM00/01
- 30006296 Headset Sleeve SM00/01 (includes Rotation stop)

**Extension set**

The base bar of the Speedmachine is design for Profile Design Aeria 3 Ultimate.

45/25 SLC extensions

10mm pads

Ergo+ armrest

Aeria Ultimate bracket

Bridge (5mm)

A3 adaptor

A3 riser kit (60mm)

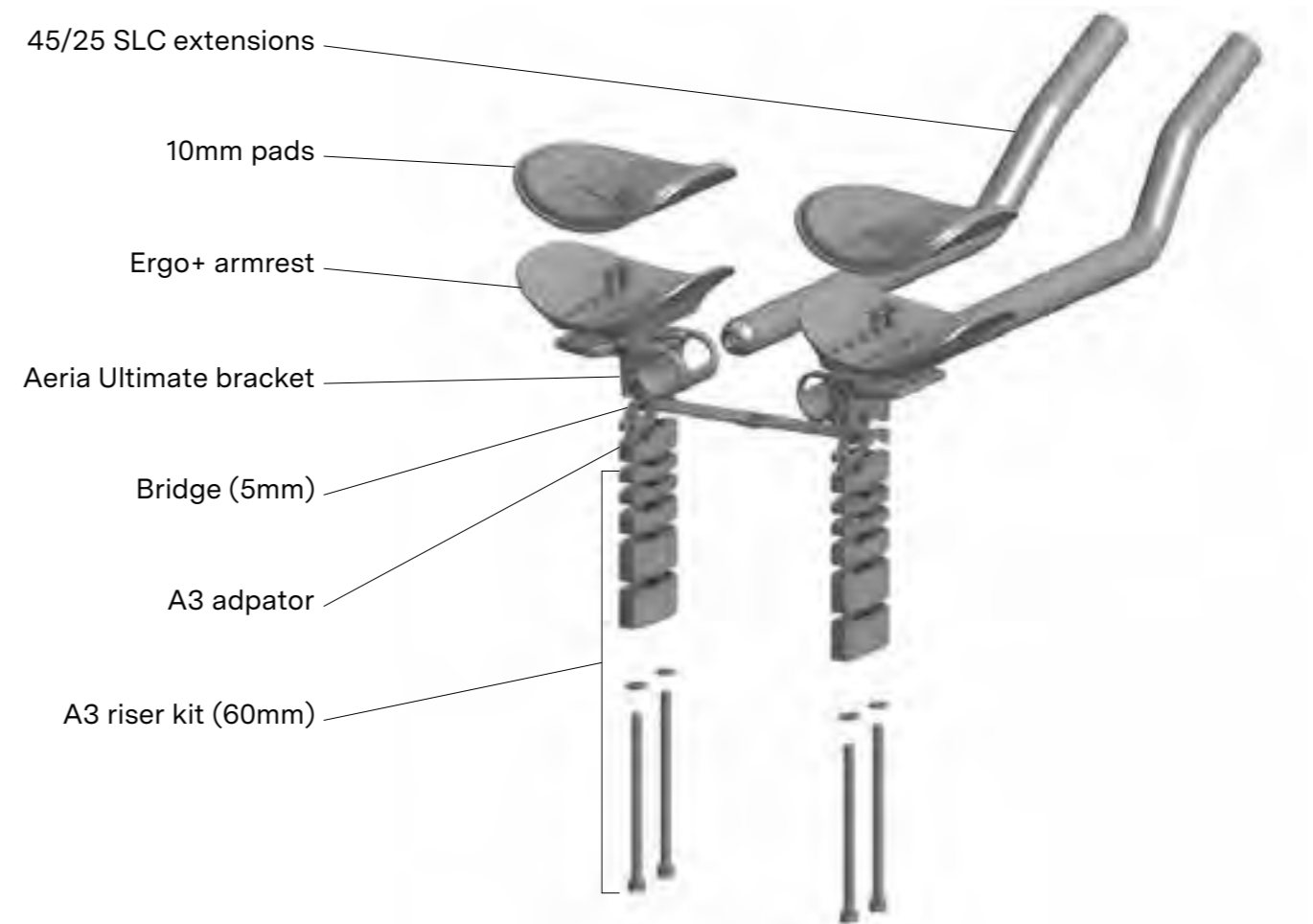

This design and its components provide a wide range of adjustment.

Depending on your frame size and in combination with the high or low base bar, you can reach a wide range of armrest positions.

Please refer to “Sizing and parts selection for the Speedmachine” page 14 for details.

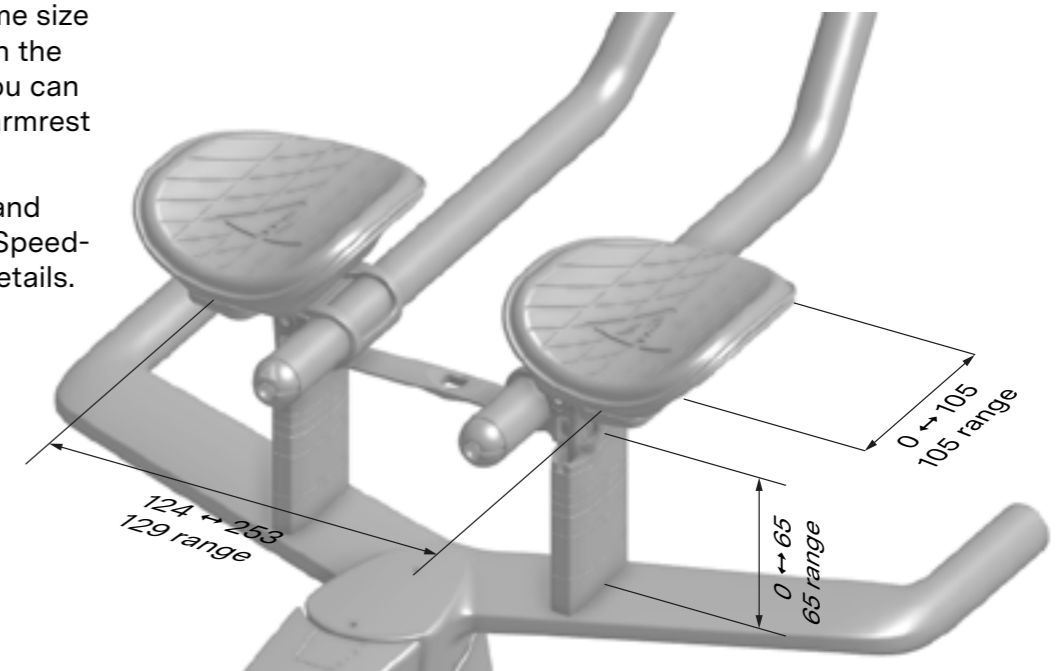

**Article numbers:**

- 30006299 Extensions Adapter and Riser Kit SM00/01

## Seatpost

### Seatpost options

The Speedmachine is delivered with a “0mm offset - forward” seatpost providing an ideal range of adjustment for Triathlon bike fitting.

Offsets of this forward seatpost are: 0, 12.5, 25mm. Seatposts length is sized according to the frame size (300mm on S, 330mm on M, 360mm on L)

An optional “25mm offset - rearward” Time Trial seatpost provides bigger offset for riders who would need more setback or to help comply with UCI regulations on the rider’s position.

Offsets of this rearward seatpost are: 25, 37.5, 50mm.

Forward seatpost



Rearward seatpost (optional)



Replacement seatposts are available in 400mm. You may have to cut this version depending on your frame size and saddle height. Please follow the recommended assembly instructions available in this manual “Seatpost assembly”, page 29.

#### Article numbers:

30006321	SP AS7, 0, 25-400
30006322	SP AS7, 0, 0-400
30006293	SP Clamp SM00/01
30006280	Seatpost Battery holder SM00/01

## Hydration

### FuelTank 1200

The Speedmachine is delivered with a triathlon specific hydration system including:

- FuelTank 1200
- Silicon hydration tube
- PROFILE DESIGN FC Bite Valve II
- PROFILE DESIGN Aeria HSF Magnet kit

The FuelTank has a capacity of 1200ml. The hydration tube gives access to the FuelTank capacity to the front of the bike and it is guided through the frame with a semi-integrated design.

- ⓘ INFORMATION: The FuelTank is F.D.A. compliant and it is BE and BPA free.
- ⓘ INFORMATION: The FuelTank 1200 is not UCI legal.

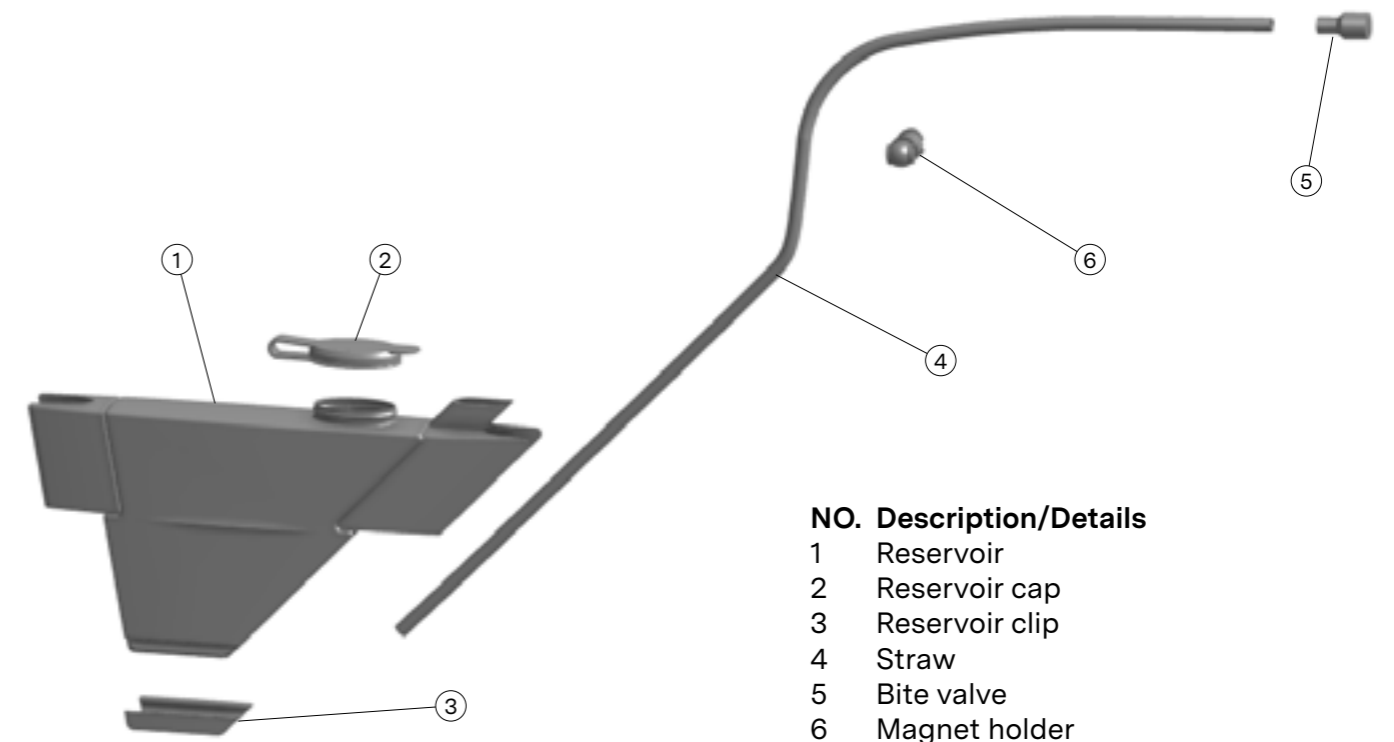

#### NO. Description/Details

- |   |                |
|---|----------------|
| 1 | Reservoir      |
| 2 | Reservoir cap  |
| 3 | Reservoir clip |
| 4 | Straw          |
| 5 | Bite valve     |
| 6 | Magnet holder  |

#### Article numbers:

30006179	TRI FuelTank 1200 SM00/01
30006181	TRI Hydration Magnet SM00/01
30006182	TRI Hydration Valve SM00/01
30006295	TRI Hydration Straw SM00/01
30006300	TRI FuelTank 1200 Lid SM00/01

### Bottle 400

For a Speedmachine in UCI configuration, an optional bottle is available. The Speedmachine Bottle 400 has a capacity of 400ml.

**Article numbers:**

30006254 BMC Rear Light 20 StVZO

**ⓘ INFORMATION:** The FuelTank is F.D.A. compliant and it is BE and BPA free.

**ⓘ INFORMATION:** The Bottle 400 complies with UCI rules.

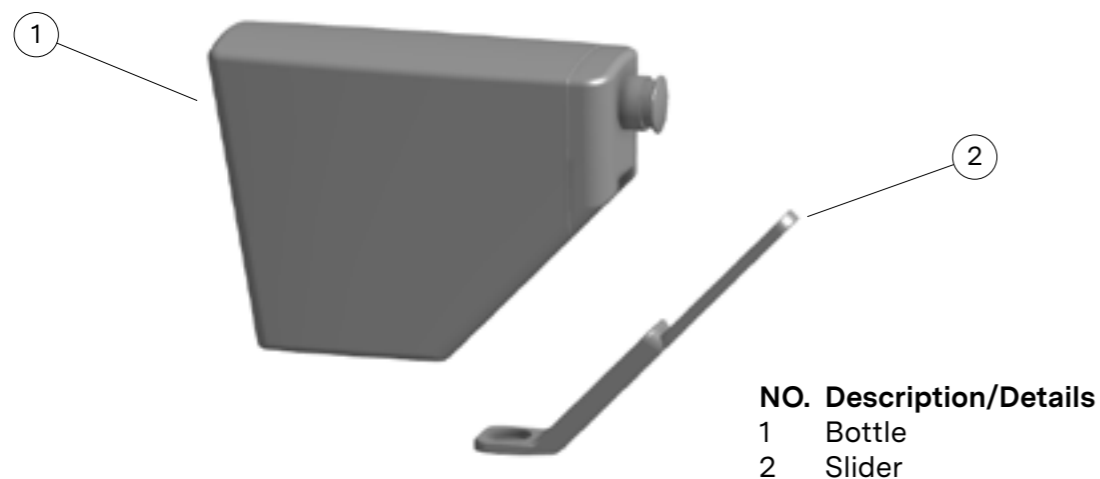

*This illustration may not match final product specifications*

**Article numbers:**

30006297 TT Bottle Mount SM00/01

30006298 TT Bottle SM00/01

### Storage

#### Rear Storage 260

The Rear Storage 260 allows you to carry your essential repair kit or any other item that may fit within its volume of about 260ml.

The central plate helps to strap securely an inner tube, a CO2 cartridge and an inflater, tire levers.

**ⓘ INFORMATION:** Rear Storage 260 is not UCI legal.

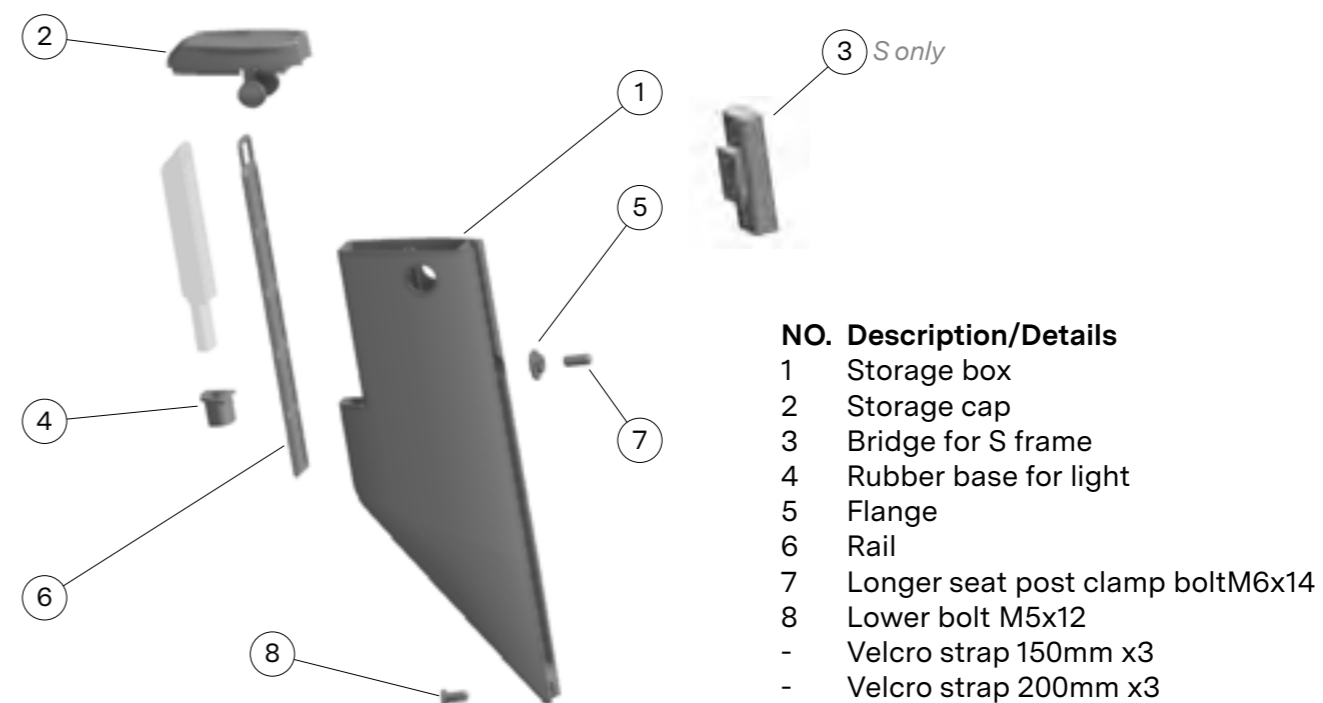

**Article numbers:**

30006180 Rear Storage 260 SM00/01

#### BMC Rear light 20 StVZO

Nicely integrated into the Rear Storage 260, our BMC Rear light 20 StVZO provides 20 lumen of brightness to keep you safe while training.

You can recharge it by USB with the provided cable and it will diffuse it's 180° light beam up to 3.5 hours run time.

StVZO approved means this light is approved to be used in all the majorities of countries in the world including Germany.

**Article numbers:**

30006254 BMC Rear Light 20 StVZO

## General notes about assembly

### Tools

Bike specific tools are required to perform the installation of your Speedmachine and its components. We recommend that you have a qualified bicycle mechanic to correctly install these components.

Before you start assembling, make sure you are equipped with the following tools:

Allen keys:

- 2.5, 3, 4, 5, 6 mm

Flat wrench:

- 11mm

Torque wrench and bits

- Hex 2.5, 3, 4, 5, 6 mm
- Torx T25

Special tools

- Carbon saw blade Park Tool CSB-1.
- Park Tool IR-1.2 Internal Cable Routing Kit

Grease compounds:

- Grease gun or grease brush
- Fine assembly grease
- Friction paste
- LOCTITE® 243 Blue

Operator protections:

- Eye protection
- Hands protection

### Repair stand

**⚠ WARNING:** Clamping the frame or its components into a bike repair stand could damage its structure or finish.

**⚠ WARNING:** Never clamp the frame by the top tube, downtube or seat tube.

Please prefer a traditional fork mount stand like the Park Tool PRS-22.2 Team Issue Repair Stand.

## Torque specifications

**⚠ WARNING:** Respecting and controlling the correct torque on fasteners is important for your safety. If too little force is applied the component will not hold safely and if too much force is applied the component thread could deform and break.

Therefore, not respecting the torque specification of any component could result in failure, which can cause loss of control and fall.

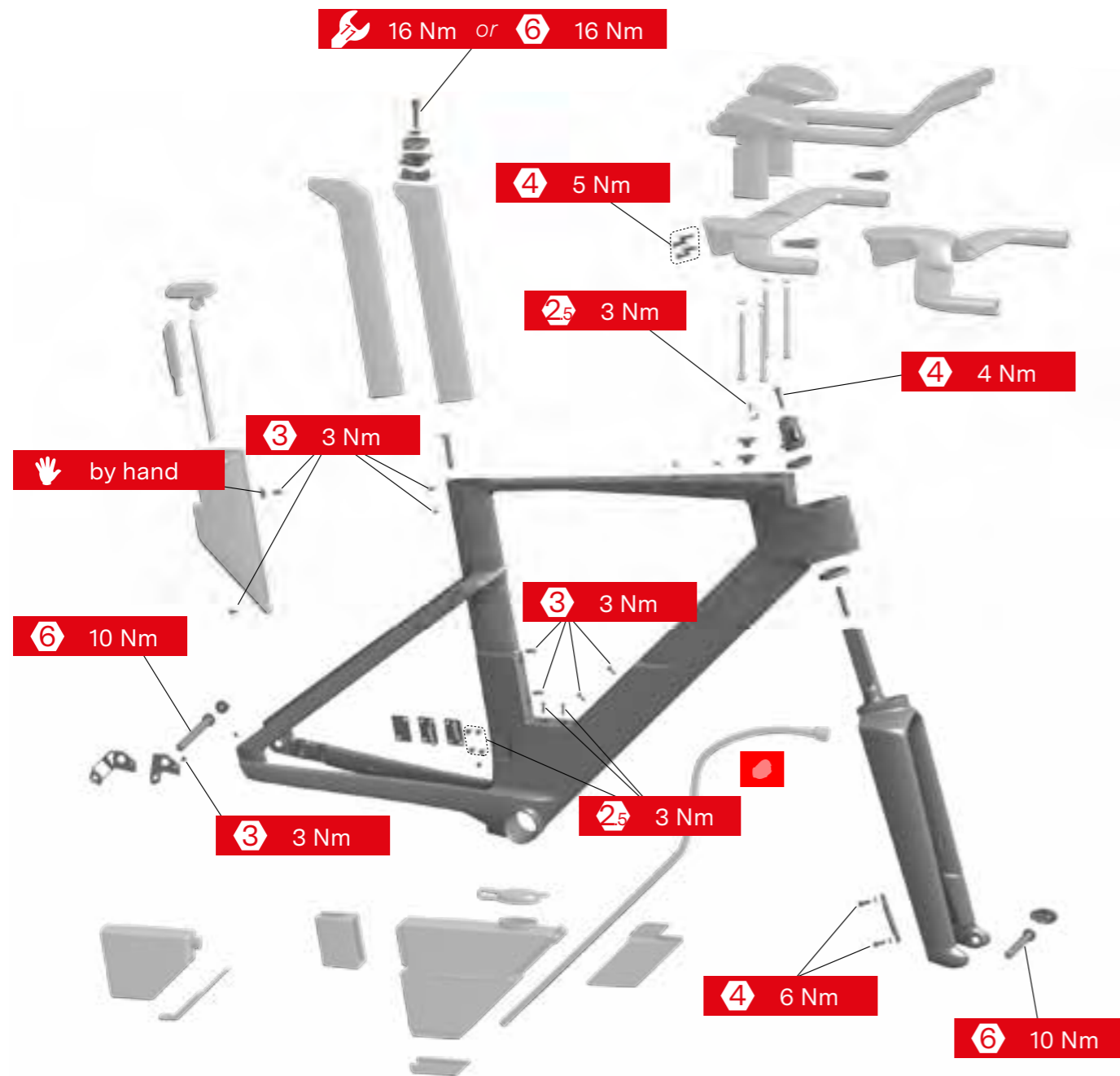

## Recommended assembly procedure

If you are building a Speedmachine from scratch, the most convenient way is to follow the order and the procedure described below. This is only the global procedure, all the separate steps and recommendations are described one by one in the next pages of this manual.

**ℹ INFORMATION:** Please go through all the instructions before starting. Following the order of this sequence will help you save time and facilitate the assembly.

1. Sizing and parts selection
2. Frame preparation
3. Fork preparation
4. Base bar preparation
5. Seatpost preparation
6. Electronic wires installation
7. Seatpost assembly
8. Brake calipers assembly
9. Headset and fork assembly
10. Bottom bracket and crankset assembly
11. Base bar assembly
12. Armrest risers, armrests and extensions installation
13. FuelTank or water bottle installation
14. Top tube storage
15. Wheels and axles

# Sizing and parts selection

## Positioning

A bicycle rider will only perform at his best if he is correctly positioned on his bike, especially for triathlon and time trial competitions.

A full sizing and components fitting guid is available on our website. It will guide you through the sizing steps and help you define the setup of the different components.

Many different handlebar types and shapes are available on the market and it is not possible for BMC to guarantee accurate positioning for all of them. The base bar, armrest set, extensions and seat post provided with the Speedmachine complete bikes and modules were carefully selected to offer the highest adjustment possibilities in a light, reliable and user-friendly package. Therefore we suggest you start by using the original Speedmachine components and carefully follow the instructions. Then, multiple customization options are described later in this manual.

## Frame size

### General frame geometry

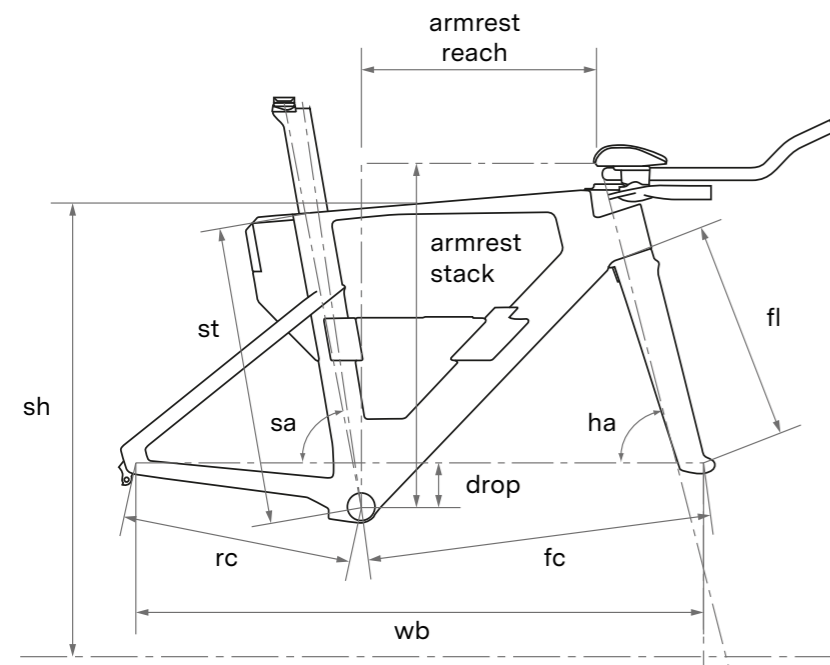

**ⓘ INFORMATION:** Values communicated are for the Flat Base bar and consider all variations of tilt.

Size	S	M	L
Rider Height cm	<174	172-185	>180
Armrest Stack (stack)	558-650	586-678	628-720
Armrest Reach (reach)	348-467	368-487	395-514
Seat Tube (st)	460	525	551
Seat Tube Angle ° (sa)	80°	80°	82,4°
Rear Center (rc)	405	405	405
Front Center (fc)	578	606	646
Wheelbase (wb)	974	1000	1040
BB drop (drop)	62	72	72
Fork Length (fl)	391	391	392
Standover Height (sh)	766	806	837

# Armrest fitting ranges

Including the effect of the tilt adjustment, this graph illustrates the Speedmachine armrests stack and reach adjustment ranges.

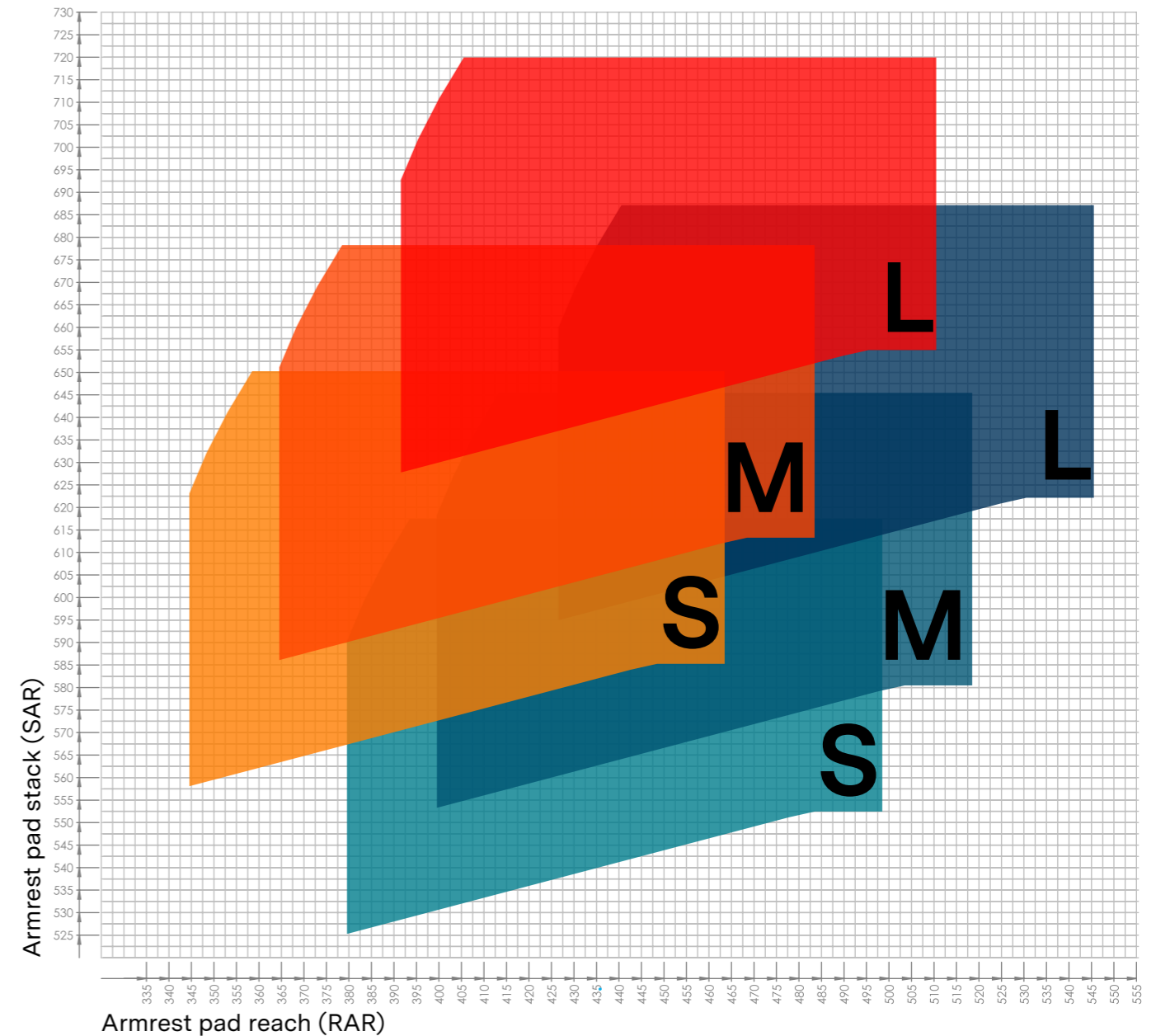

## Detailed assembly instructions

### Frame preparation

#### Rear derailleur hanger installation

- Select the right model of hanger depending on your groupset, and the rear derailleur design. You can choose between the standard dropout hanger or the direct mount dropout hanger. The Direct Mount hanger is usually specified for SHIMANO latest generation of derailleurs.

Standard



Direct mount



- Position the selected dropout hanger on the frame dropout and bolt on the M4x8 bolt using a hex 3mm.
- Tighten to 3 Nm.

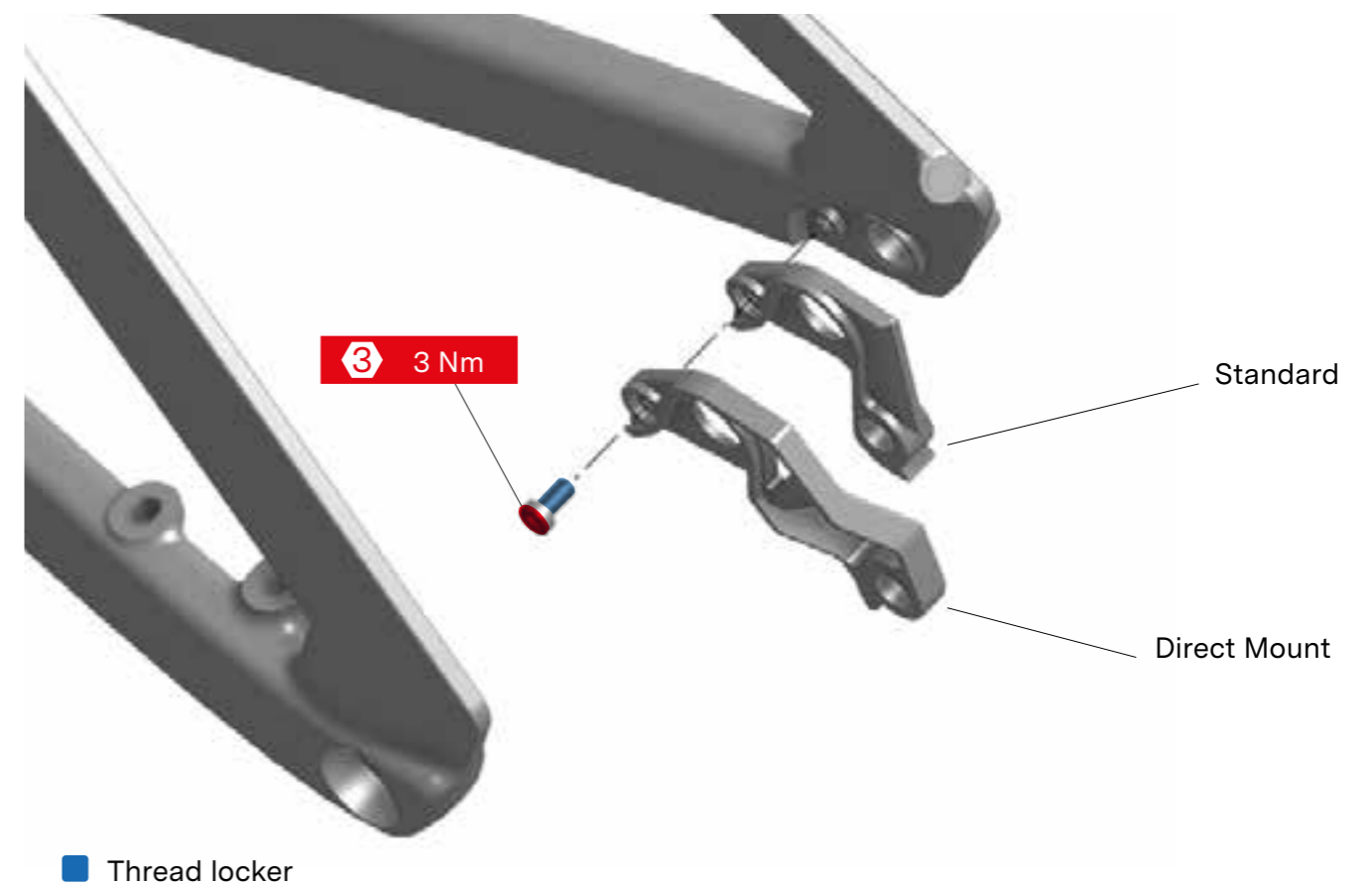

### Front derailleur hanger installation

- Select the right model of hanger depending on your groupset, the chainring configuration, and the front derailleur design.

You can choose between 3 front derailleur hangers:

- 1x single chainring - no front derailleur - flat plate
- 2x double chainrings standard with front derailleur standard mount 141mm to 153mm SRAM 46-54, SHIMANO 50-56
- 2x double chainrings big with front derailleur high mount 153mm to 161mm SRAM 52-59, SHIMANO 56-60
- Position the selected dropout hanger on the frame and bolt on the M4x8 bolts using a hex 2.5mm.
- Apply thread locker onto the bolts threads

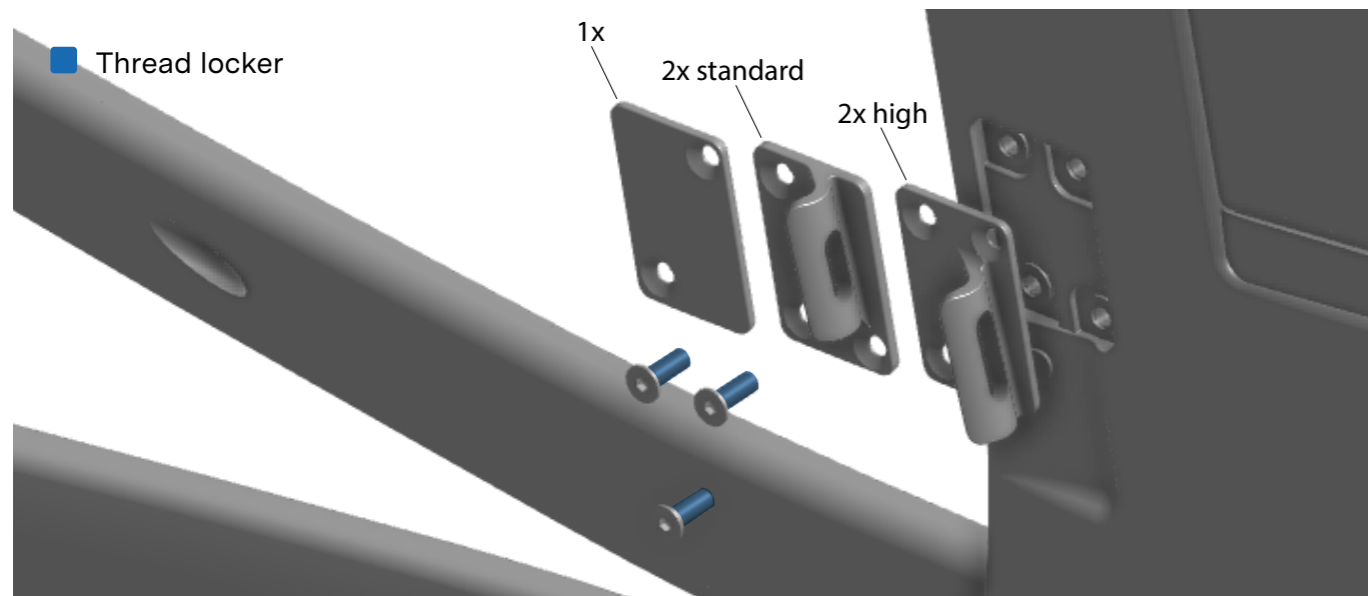

- Tighten to 3 Nm using a hex 2.5mm.

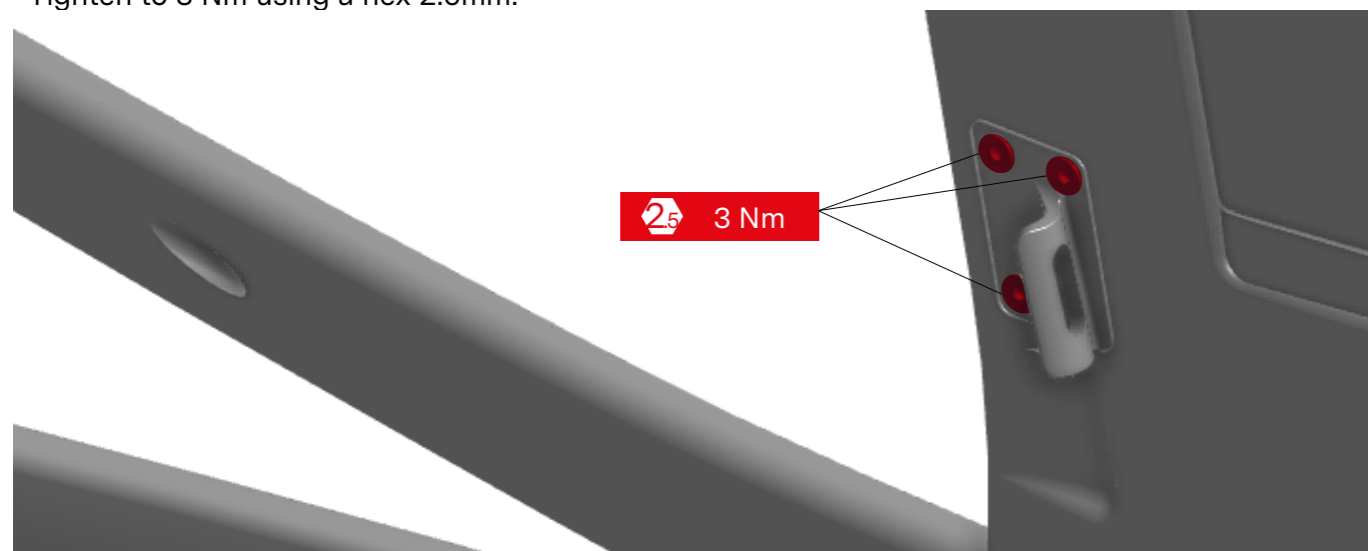

### Fork preparation

The fork provided with the frameset or the bike is already cut to size and to the specific angle required for your frame size.

There is no need to adjust this length for a change of cockpit.

### Base bar preparation

#### Cutting instructions

The base bar grip section is adjustable to your own preference or hand size. You can cut up to 30mm.

**i** INFORMATION: Best if use an appropriate carbon specific saw blade such as the Park Tool CSB-1.

**⚠** WARNING: If cutting the base bar grip section, make sure to respect the maximum cutting instruction.

**⚠** WARNING: Before cutting, always check the minimum insertion required by your brake levers.

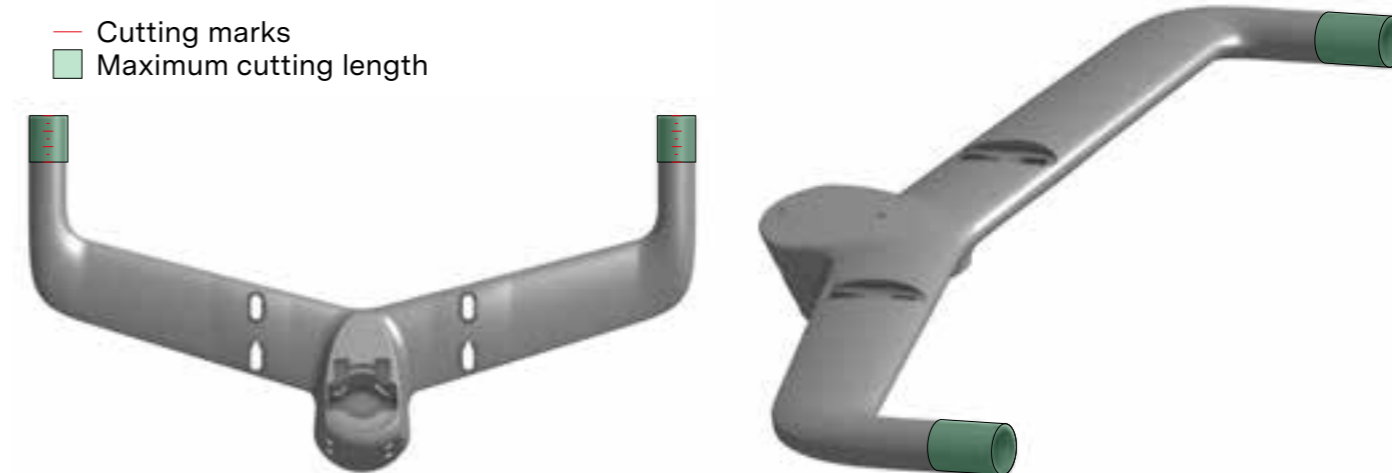

## Seatpost preparation

### Seatpost length

The two seatposts compatible with the Speedmachine have a minimum and a maximum insertion depth in the frame.

	S	M	L
Seatpost length	300	330	360
Mini insertion	70	70	70
Max insertion	180	200	200

**⚠ WARNING:** Always make sure you are respecting the Mini insertion length of 70mm.

**ℹ INFORMATION:** If the max insertion is too restricting and does not allow a low enough saddle height adjustment, you can cut your seatposts to a shorter length to allow you to reach your ideal saddle height.

**ℹ INFORMATION:** Use a saw guide like the Park Tool SG-7.2 Oversized Adjustable Saw Guide and an appropriate carbon specific saw blade such as the Park Tool CSB-1.

**⚠ WARNING:** If cutting the seatpost, make sure to respect the maximum cutting instruction.

- Decals
- Maximum cutting length

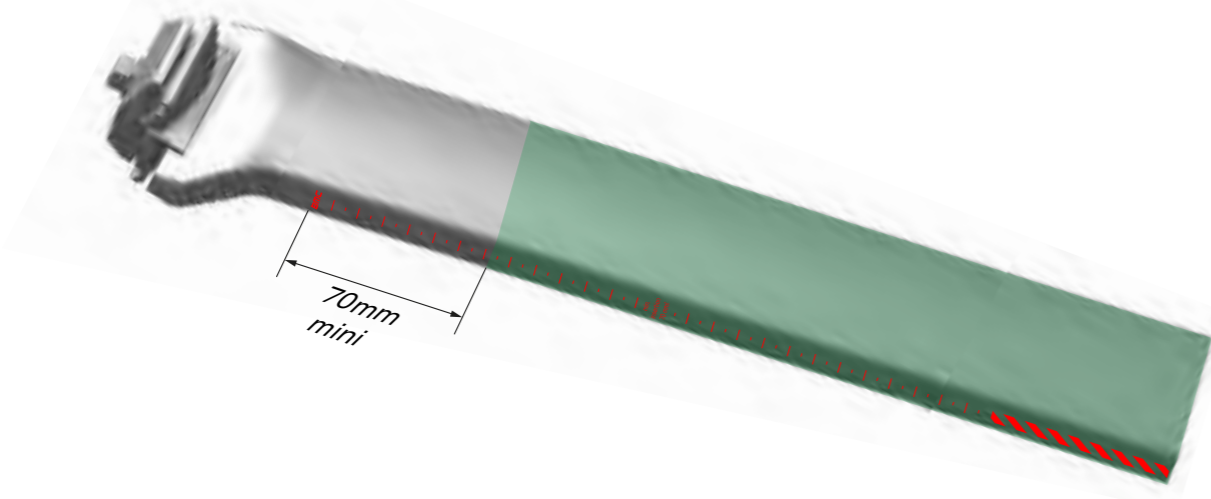

## Electronic wires installation

### SHIMANO DI2

**⚠ WARNING:** Please always refer to the latest SHIMANO product information for your groupset. The following information is a guide with basic principles.

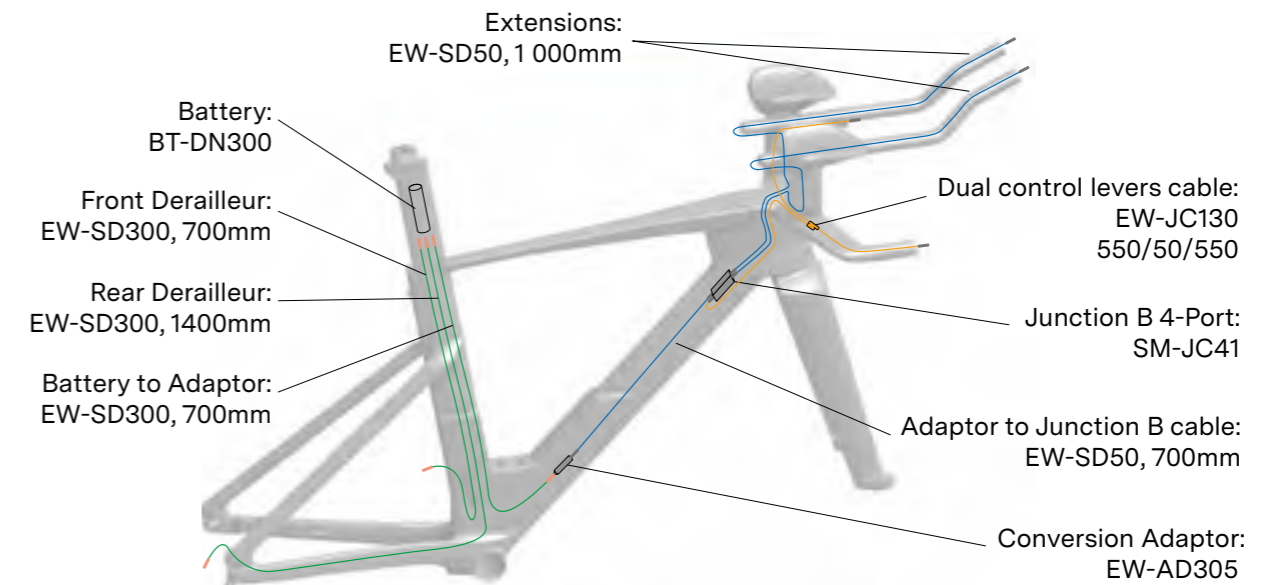

Recommended wire lengths:

Location	Part code	Length
Front Derailleur	EW-SD300	700mm
Rear Derailleur	EW-SD300	1 400mm
Battery to Adaptor	EW-SD300	700mm
Adaptor to Junction B	EW-SD50	1 000mm
Extensions	EW-SD50	1 000mm

• Install the different electronic wires into the frame and the cockpit.

**ℹ INFORMATION:** It helps a lot to use a cable routing guiding tool like the Park Tool IR-1.2 Internal Cable Routing Kit

• Install the battery in the seatpost using the supplied battery holder and the o-ring.

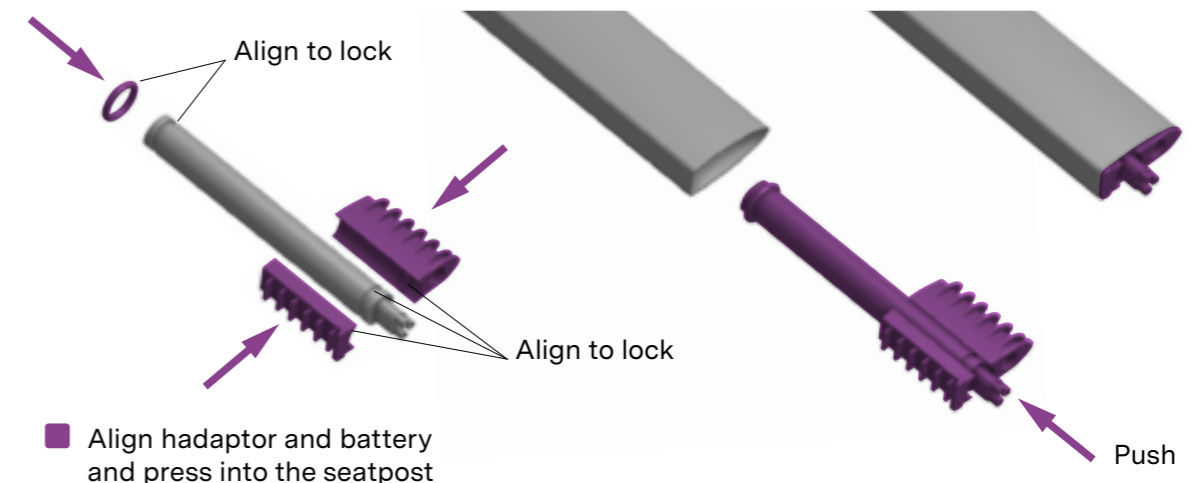

## SRAM AXS

Please always refer to the latest SRAM product information for your groupset. The following information is a guide with basic principles.

### Installation option A: full wireless system

By only using the eTap AXS Wireless Blips (EC-BLIP-B1) paired with the eTap AXS Blip-Box (ES-EAC-BBOX-D1), you don't need any electronic wire to be routed through the frame or cockpit.

In a full wireless system, the eTap AXS BlipBox is only necessary for pairing.

Once paired, you can choose to either attach the eTap AXS BlipBox to the base bar or extension bridge -or- store it somewhere safe at home as you will not need it for the bike to function normally.

### Installation option B: mix wired and wireless

You could prefer the shape of the eTap Clicks (ES-EAC-CLIC-A1) on the extensions and the eTap AXS Wireless Blips (EC-BLIP-B1) on the base bar. These shifters need to be connected and paired with the eTap AXS BlipBox (ES-EAC-BBOX-D1).

The eTap AXS BlipBox can either be attached to the to the base bar or extension bridge.

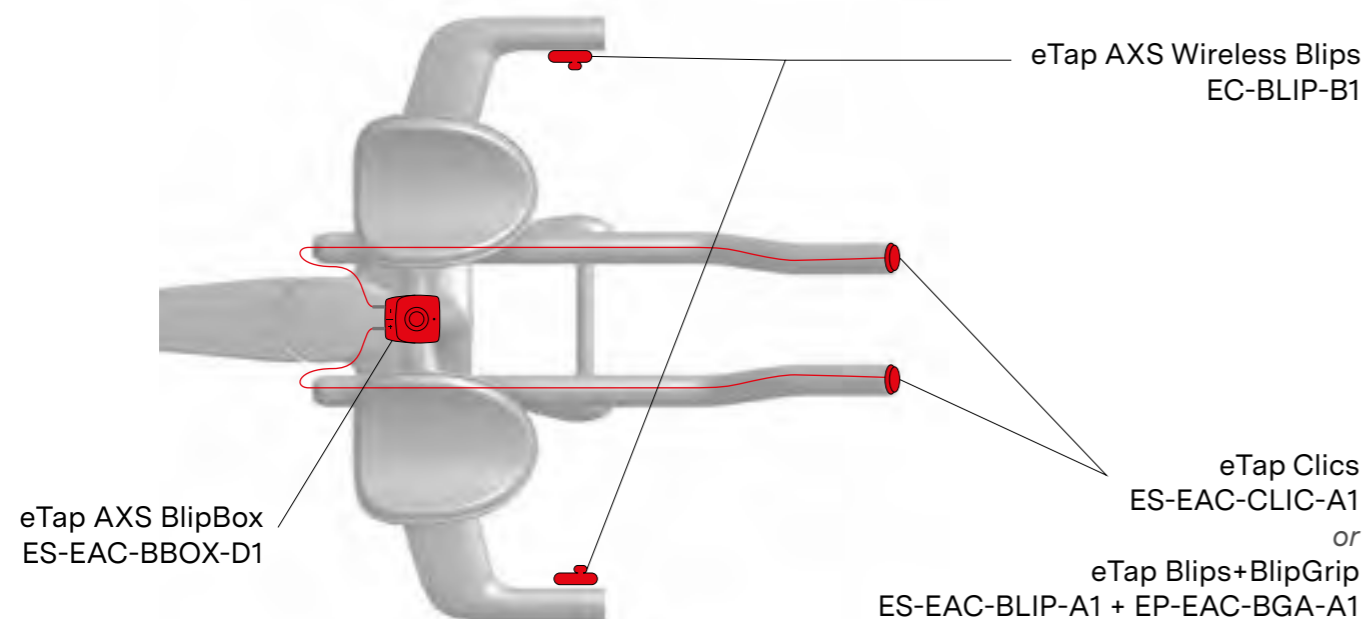

## Seatpost assembly

### Saddle clamp installation

- Install saddle clamp on your desired seatpost using one of the 3 offsets available.
- For more details, please refer back to the previous paragraph "Seatpost", page 12. and "SPEEDMACHINE Gen1 Owners Manual - V1 - September 2023 - English", page 3.
- Pre-install the clamp support, the lower clamp, the upper clamp, the washer and finally pre-install the M8x35 bolt. Only tighten by hand at this point.
- Install your saddle by clamping the rails between the 2 clamps and adjust the saddle set-back and tilt before clamping the M8x35 saddle clamp bolt.
- Tighten to 16 Nm using either a hex 6mm or a 11mm flat wrench.

**⚠ WARNING:** Always tighten to torque as Triathlon and TT saddle and position are applying a lot of force on the saddle clamp. Not respecting this recommendation may result in getting the saddle loose, losing control of the bike and eventually falling.

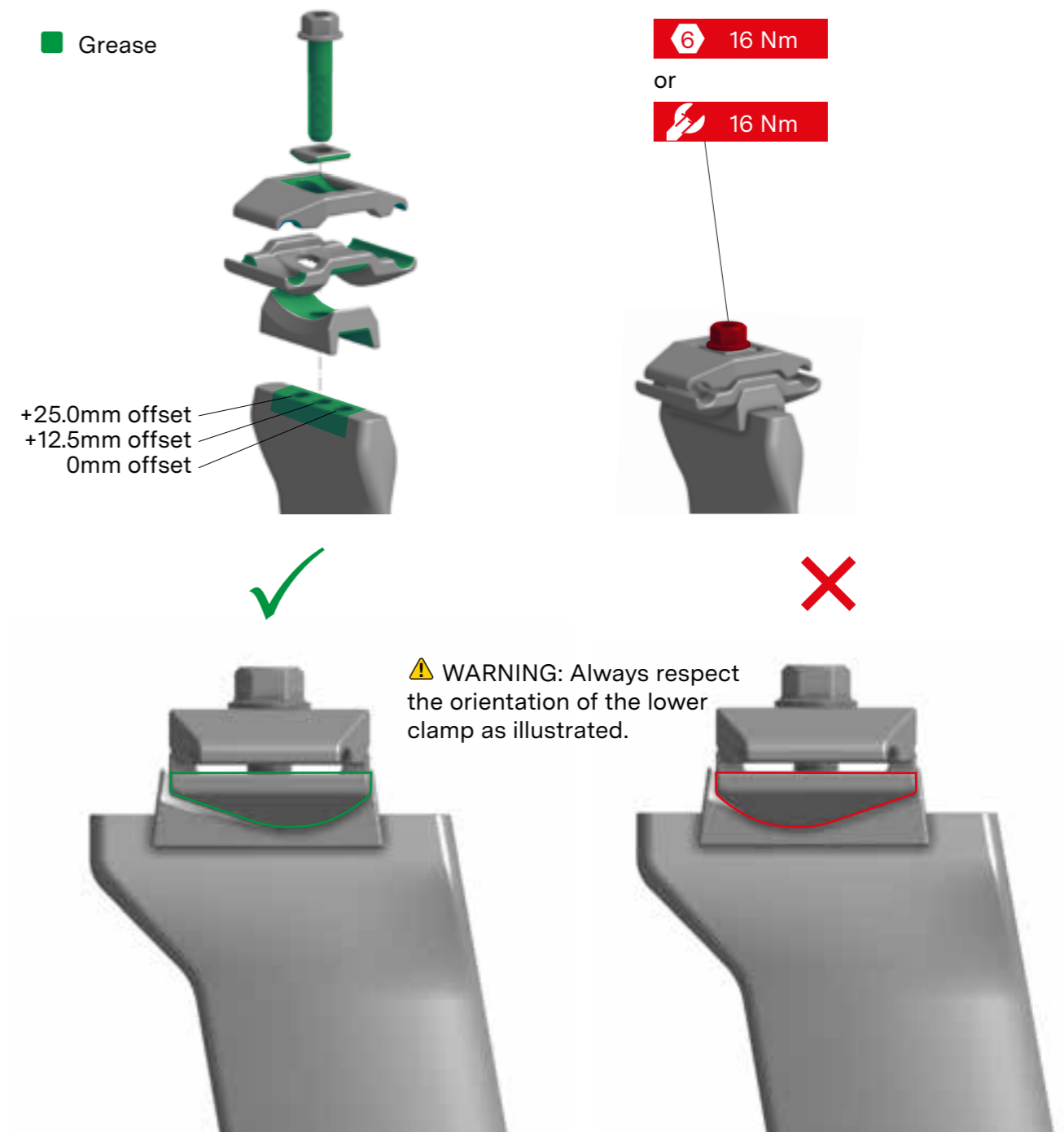

## Frame seatpost clamp installation

- Apply a thin layer of friction paste onto the frontal surface of the seatpost tube.
- Grease the 2 compression M6x10 and M6x14 socket set bolts and install them into the frame threads without tightening.

For a small frame size (S)

- The longer bolt M6x14 is to install at the top.
- The shorter bolt M6x10 is to install at the bottom.

For a medium or a large frame size (M or L)

- The shorter bolt M6x10 is to install at the top.
- The longer bolt M6x14 is to install at the bottom.

- Slide the flat shim in the seat tube and slide the seatpost.

**⚠ WARNING:** Failing to use the shim will damage the seatpost as bolts will damage the seatpost when tightening.

- Insert the seatpost to your desired saddle height.

**⚠ WARNING:** Remember to respect the minimum insertion of 70mm. Not respecting the minimum insertion could result in frame or seatpost damage, break and injury.

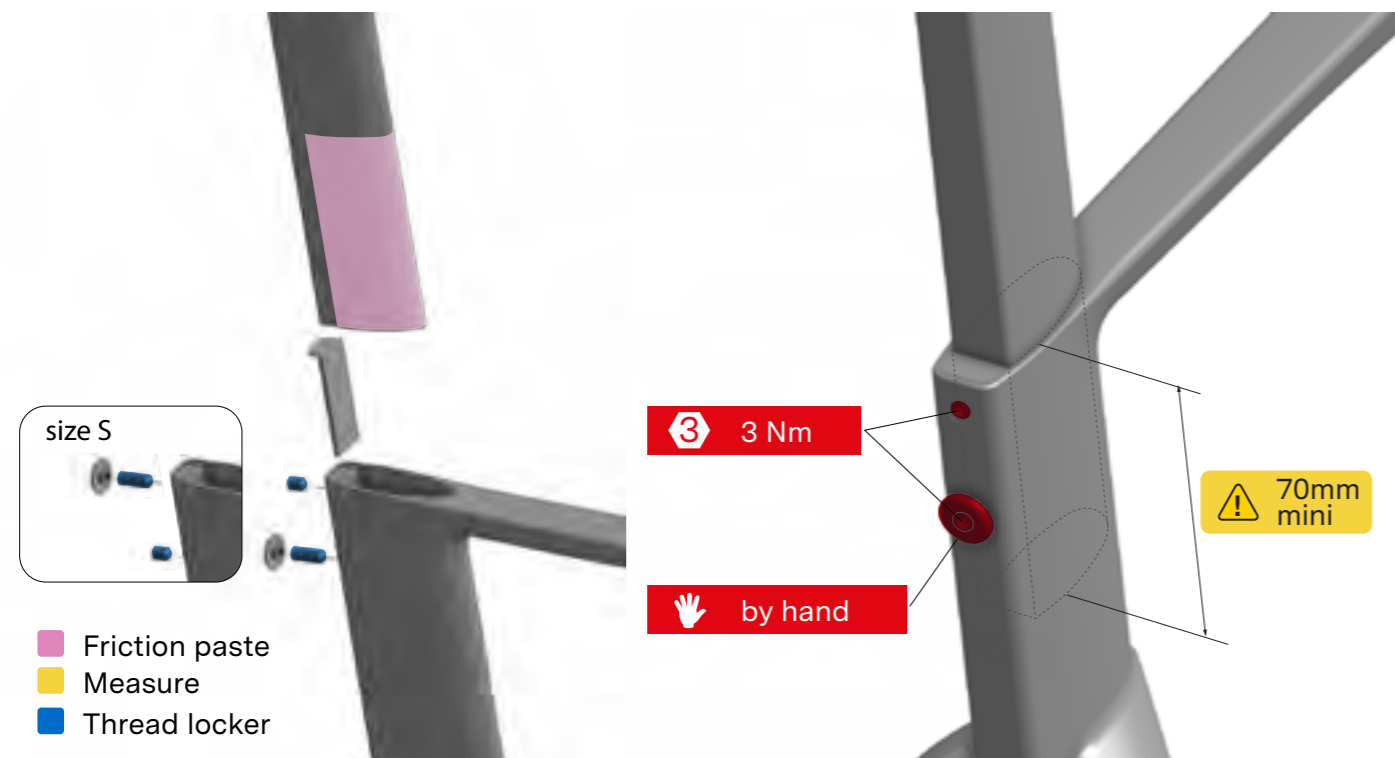

- Tighten both M6x10 and M6x14 bolts to 3 Nm using a hex 3mm wrench.

- If you are looking to ride with the Rear Storage 260, install the flange on the longer bolt. The Rear Storage 260 module requires this flange to be installed on the longer bolt.

- Tighten the flange by hand or using a circlip pliers.

**⚠ WARNING:** Do not over tighten the flange.

## Brake calipers assembly

### Rear brake

The rear brake must be installed either:

- Directly on the frame brake mount for 140mm rotor compatibility or
- Using a 20mm bracket for 160mm rotor compatibility

- Push the rear brake hose from the back to the front inserting it in the left chainstay ingress. Guide the hose through the head tube and let it exit at the top.

Select the rear brake adapter and bolts. Refer to brake caliper's manufacturer's to determine:

- The correct adapter plate based on your rotor size.
- The correct bolt length and the appropriate torque value.
- Bolt on the rear caliper on the flat mount brake mount using appropriate bolts and follow brake manufacturer recommendation for installation (thread locker and torque)

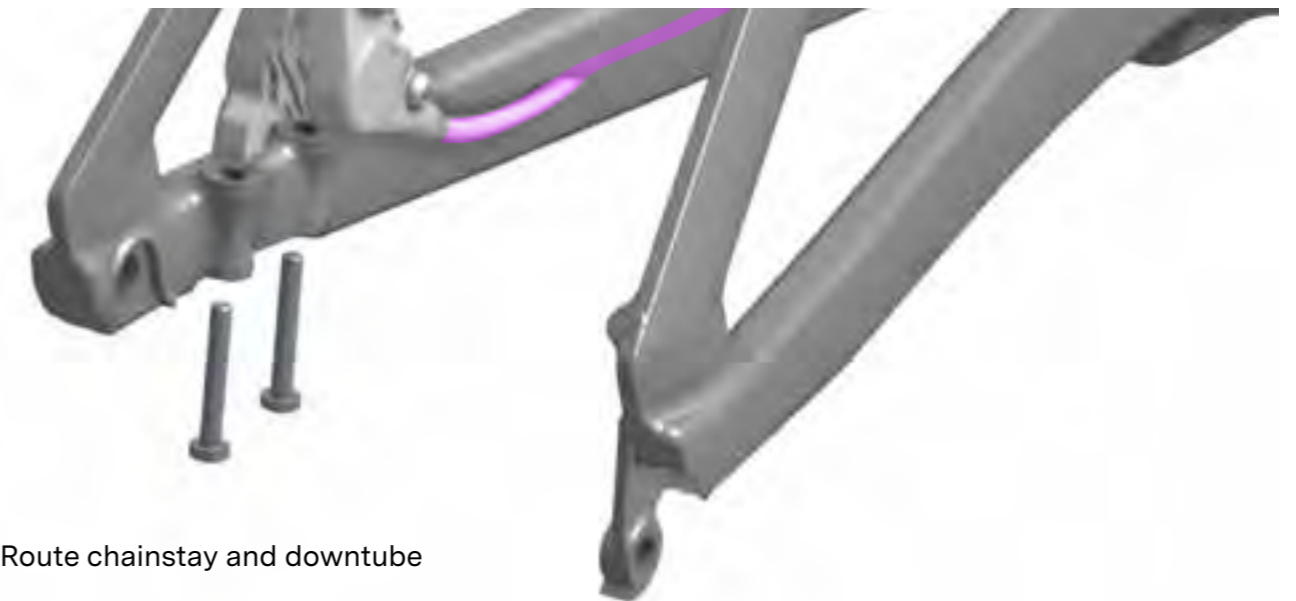

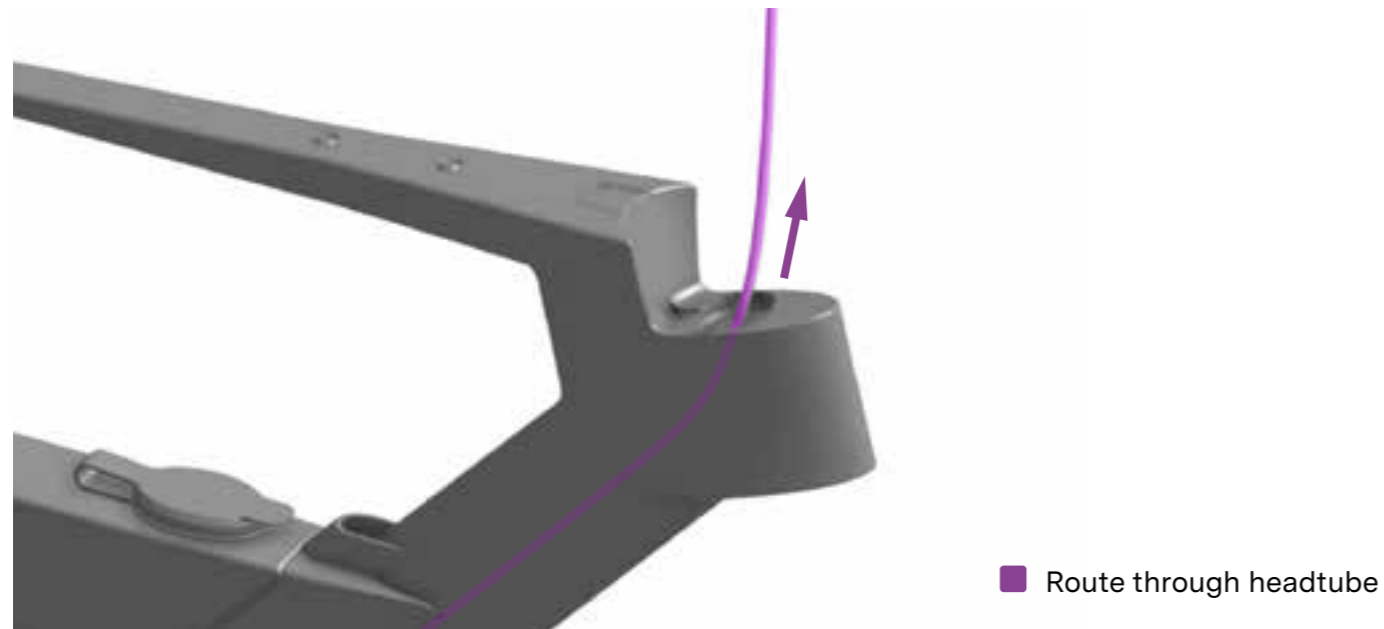

- Slide the hose into the foam tube and through the head tube. The foam tube should be slid into the downtube to avoid the brake hose to rattle in the frame.



### Front brake

The front brake must be installed directly on the specific BMC front bracket adapter. The Speedmachine is designed for 160mm front rotor only.

⚠ WARNING: There are multiple front brake adapter plate designs. Make sure you are using the part provided with the Speedmachine.

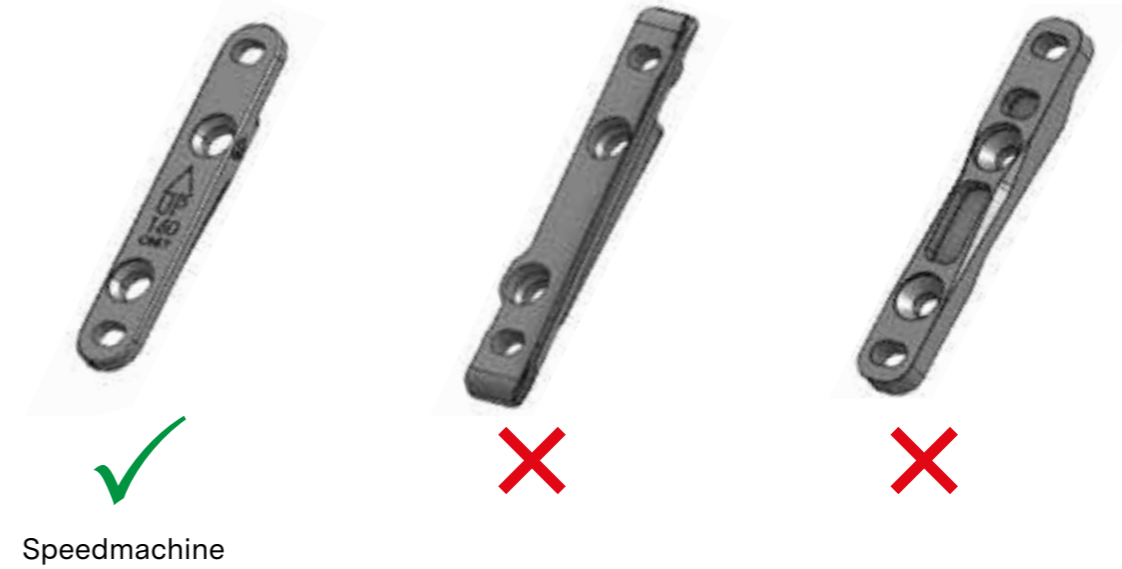

- Install the front caliper adapter plate onto the front caliper.
- Make sure the brake mount is in the correct position. The “UP” mark must face up and out, as shown in the illustration below.

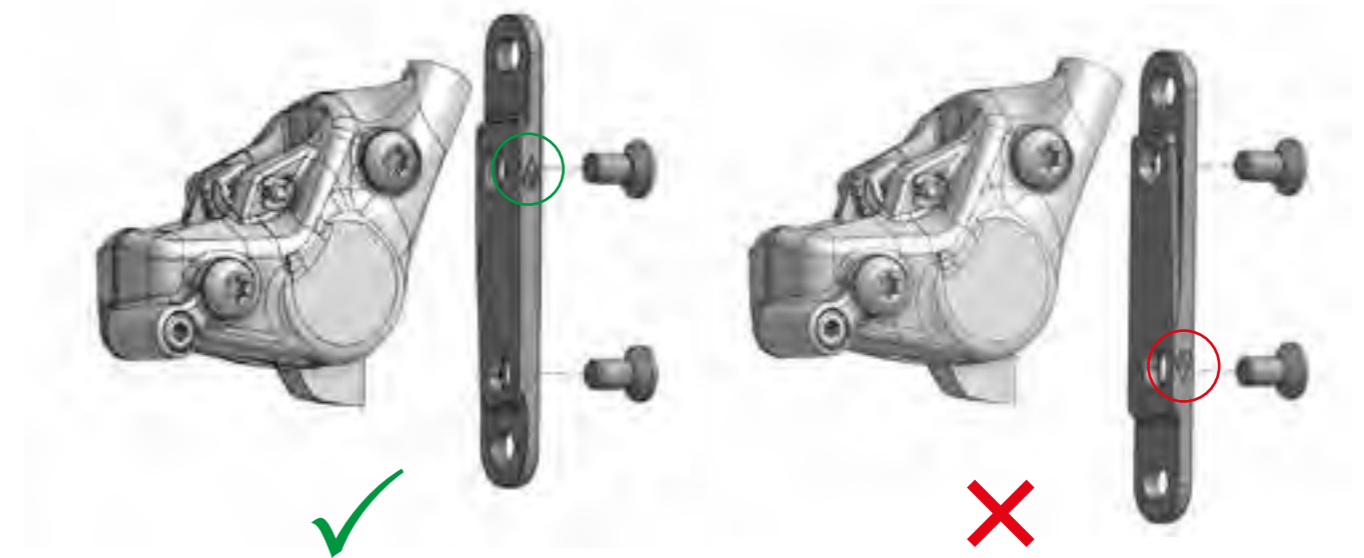

- Torque the countersunk bolts to the brake caliper manufacturer’s recommendation.
- Route the rear brake hose through the fork
- Install the front brake adapter to the fork mount using the 2 M5x14 bolts.

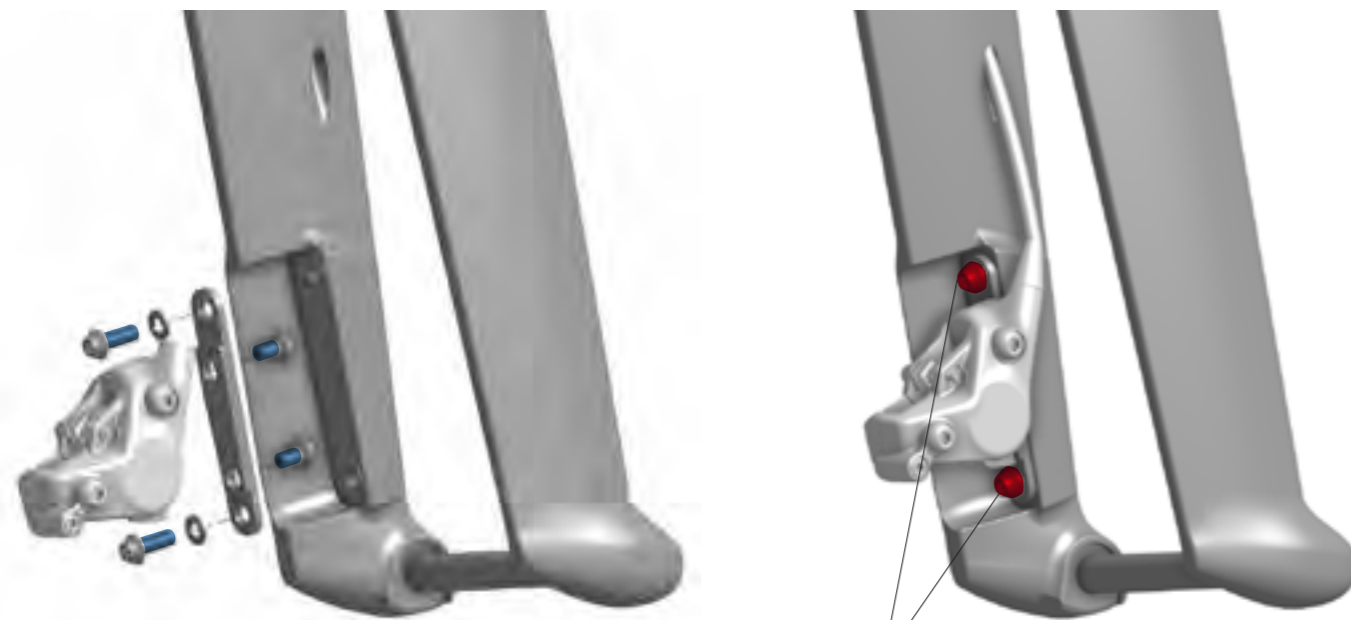

- Tighten to 6 Nm using a hex 4mm wrench.
- Thread locker

**4 6 Nm**

## Headset and fork assembly

The Speedmachine is designed to fit high grade stainless steel headset bearings from Enduro Bearings.

Specifications of these bearings are:

	Reference	Dimensions
<b>Upper bearing</b>	ACB 4545 1125T SS-bx	30.15x41x7; 45x45°; 1.125" SS
<b>Lower Bearing</b>	ACB 4545 125L SS-blk	34.1x46.8x7;45x45°; 1.25" SS HS 970

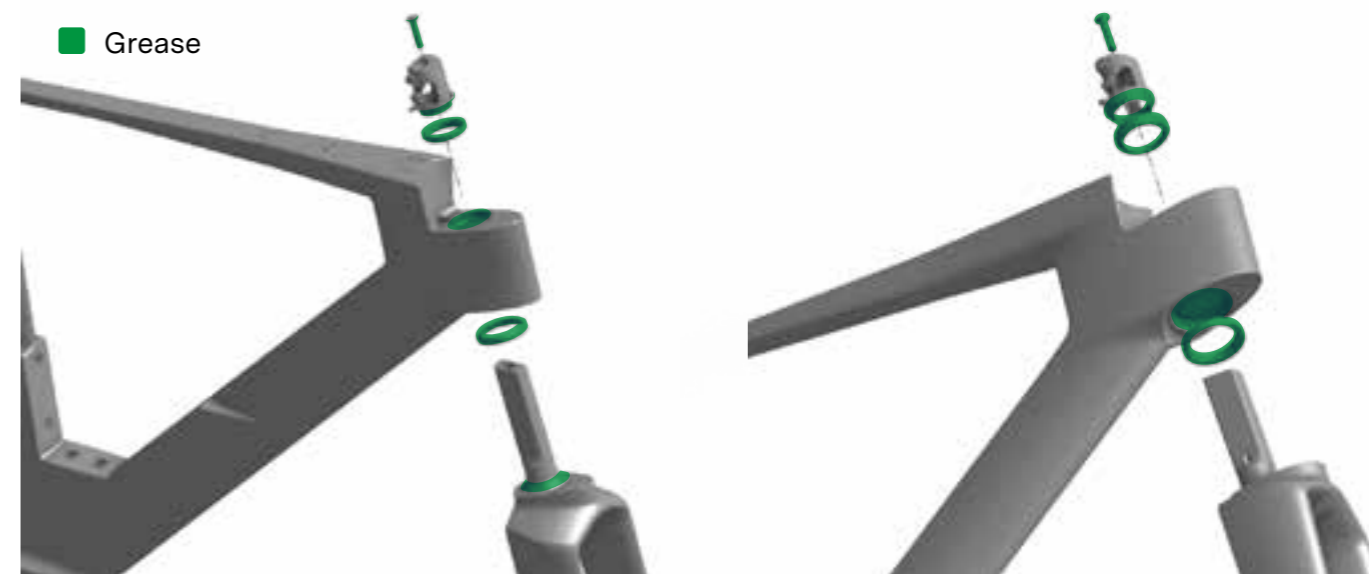

- Install the upper bearing in the frame head tube using grease in the bearing race and onto the bearing surfaces.
- Front and rear brake hose should be routed through the upper bearing.
- Install the lower bearing in the frame head tube using grease in the bearing race and on the bearing surfaces. The grease should help the lower bearing to stay in place by sticking.
- Route the front brake hose on the right side of the steerer tube, hold the rear brake hose on the left side of the head tube and insert the fork steerer tube through the head tube and headset bearings.
- Slide the headset sleeve onto the steerer tube with its round face facing forward (flat face to the back).

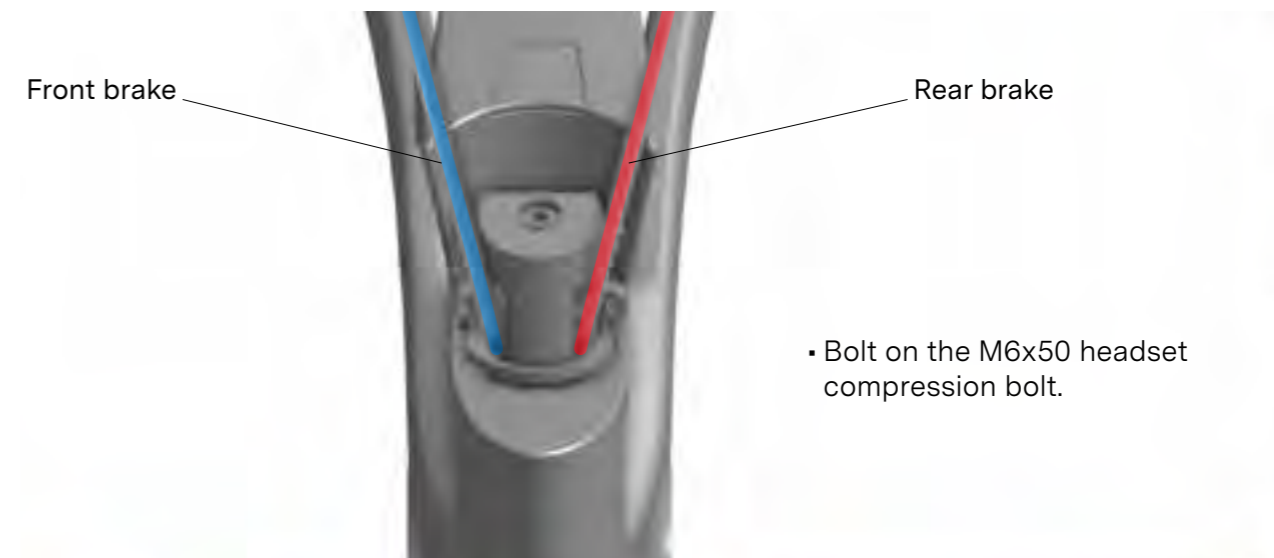

- Bolt on the M6x50 headset compression bolt.

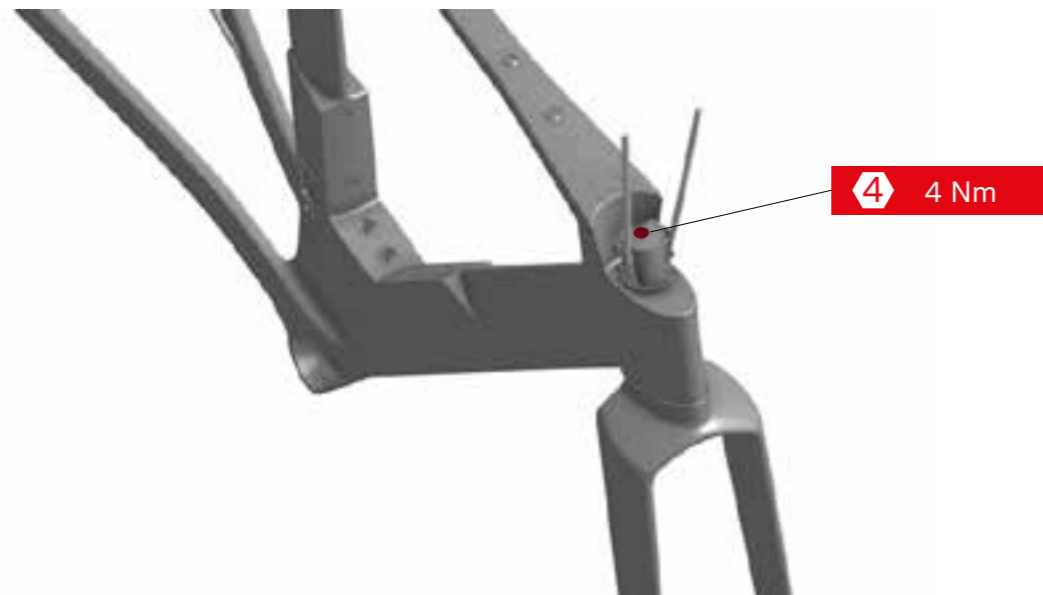

• Tighten to 4 Nm using a 4 hex wrench.

⚠ WARNING: No friction paste should be applied on the steerer tube or on the bearings.

### Bottom bracket and crankset assembly

Now that all the cables and brakes hoses are installed, you can install the bottom bracket and the crankset.

The Speedmachine uses a T47x68mm bottom bracket.

We usually recommend to apply grease on bottom bracket mounting threads and contact surfaces but some manufacturers of bottom bracket sets may recommend thread locker.

⚠ WARNING: Please follow the bottom bracket and crankset instruction for installation.

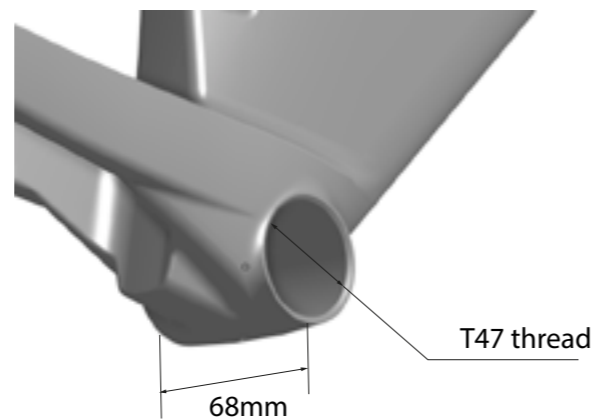

### Base bar assembly

Prior to proceed to the base bar installation, you should define how your brakes should be installed.

- Standard Style Brake-Assembly:  
[Front brake] from [Left lever] & [Rear brake] from [Right lever]
- UK Style Brake-Assembly:  
[Front brake] from [Right lever] & [Rear brake] from [Left lever]

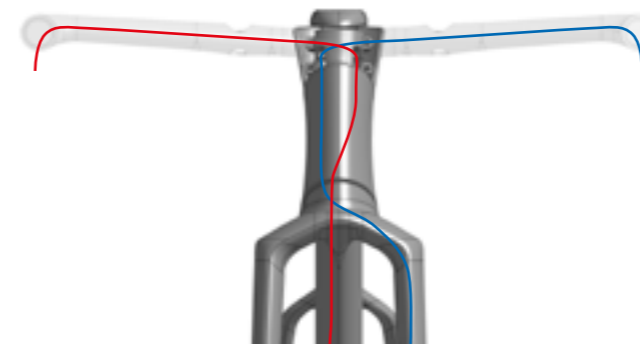

Standard Style: cross brake hose

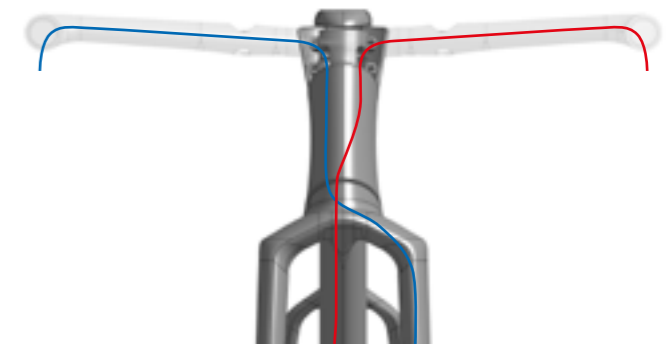

UK Style: no hose crossing

• Route the brake hoses according to your preferred style.

ⓘ INFORMATION: It's easier to route the brakes hoses before installing the Armrest and riser kit.

ⓘ INFORMATION: The brakes hoses should be routed between the riser kit bolts. This is where you will find the easiest path.

Hose ingress

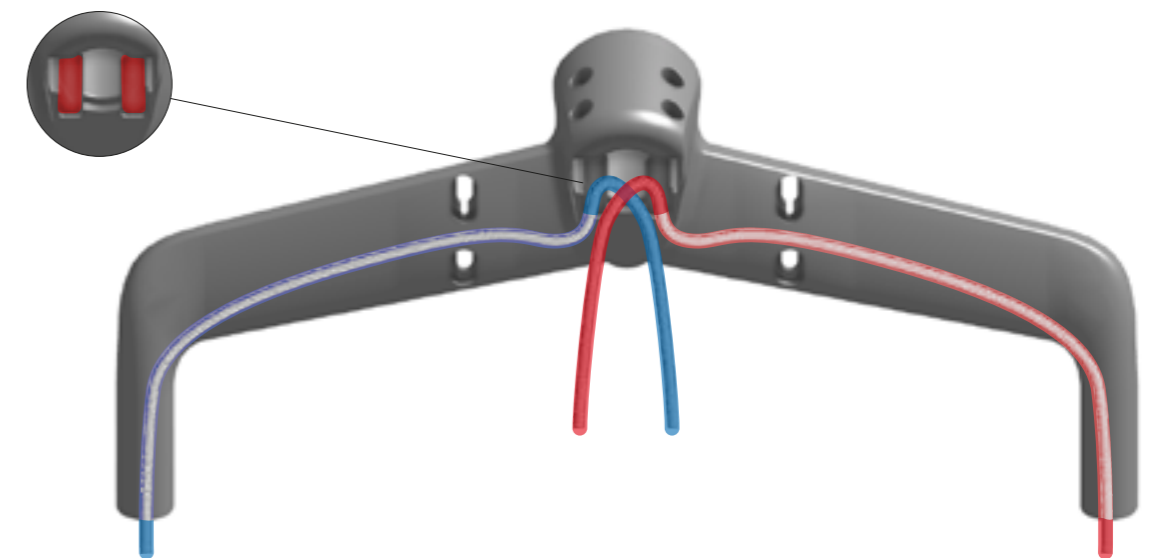

ⓘ INFORMATION: It shouldn't be necessary but sometimes it helps to use a cable routing guiding tool like the Park Tool IR-1.3 Internal Cable Routing Kit

Align and slide over

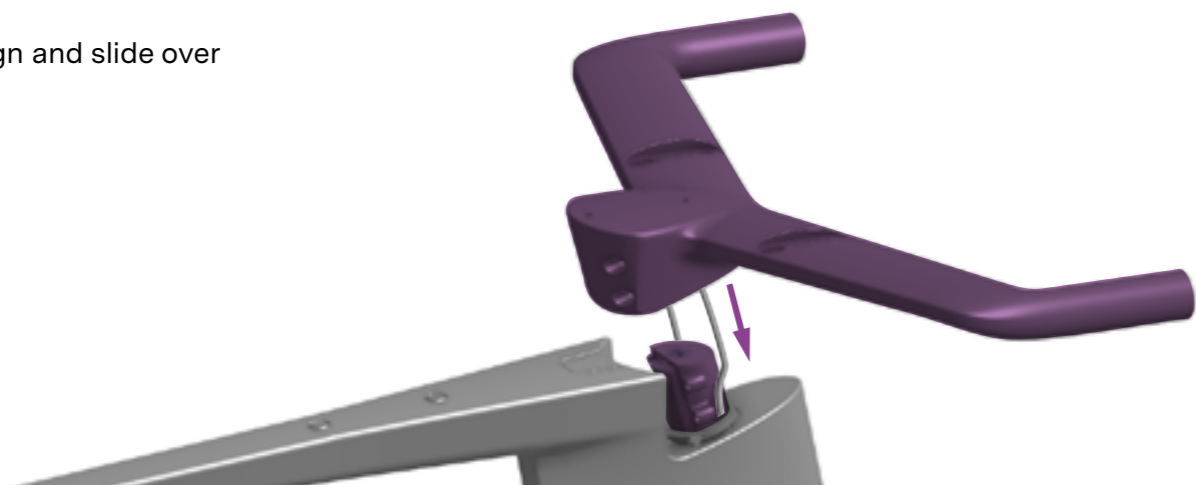

Install the base bar onto the headset sleeve.

**INFORMATION:** It will help to pull the brakes hoses from the base bar grip to help push the base bar onto the headset sleeve.



Thread locker

Turn the bar on one side and install 2 of the M5x16.5. Tighten lightly.  
Turn the bar to the other side and install the other 2 M5x16.5 bolts

**WARNING:** Bolt on the bolts completely in order to avoid their head to damage the frame paint when turning the bar.

**WARNING:** If necessary, replace the original thread locker compound by a fresh coat of LOCTITE 243.

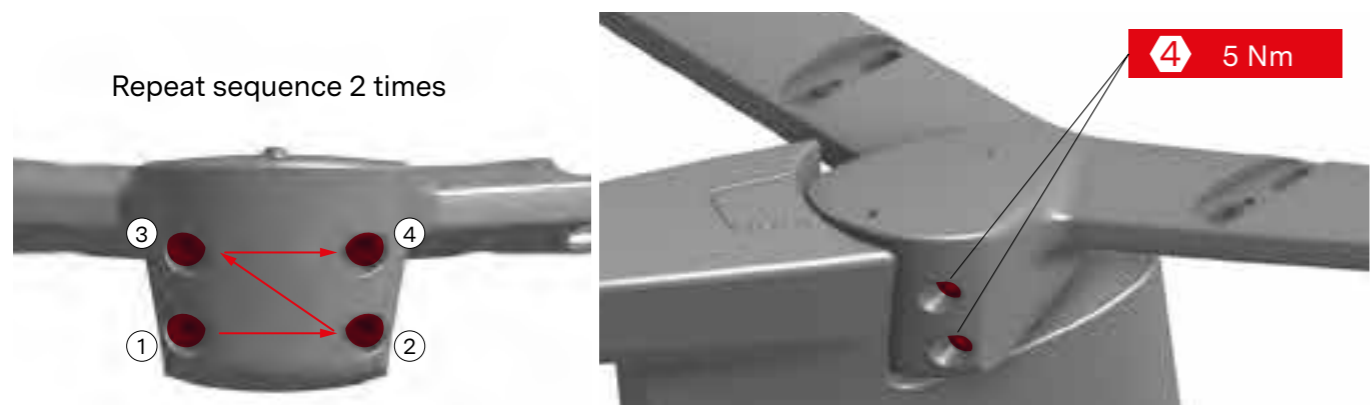

Follow the tightening sequence as illustrated: lower left, lower right, upper left, upper right and repeat 2 times. Tighten the 4 bolts to 5 Nm using a 4 hex wrench.

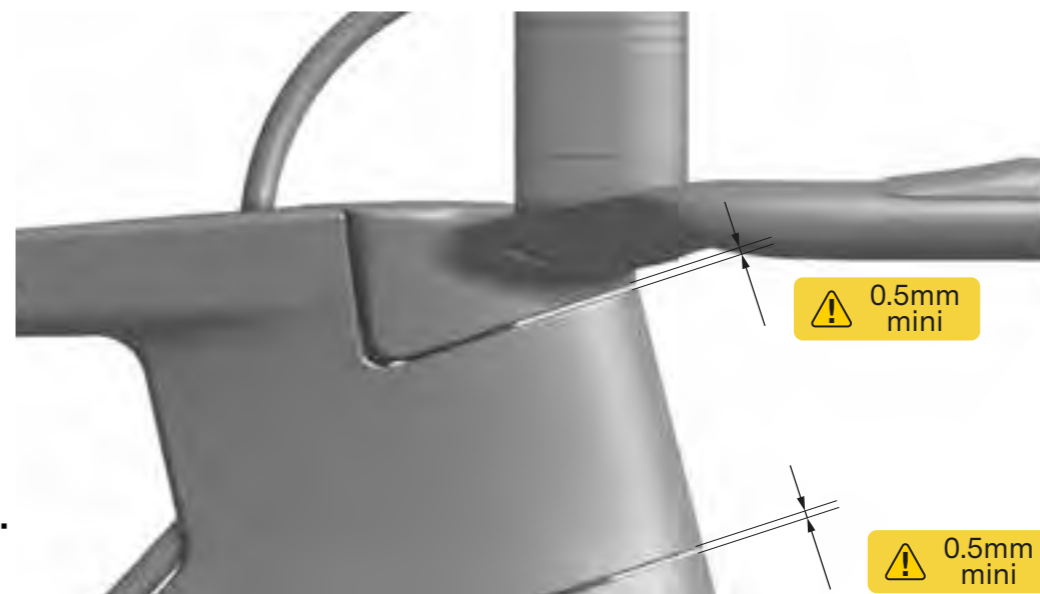

**WARNING:** Once handlebar bolts are tighten to specifications, control the space required between the base bar and the top of the head tube as well as between the head tube and the fork crown.

The clearance must be of 0.5mm minimum.

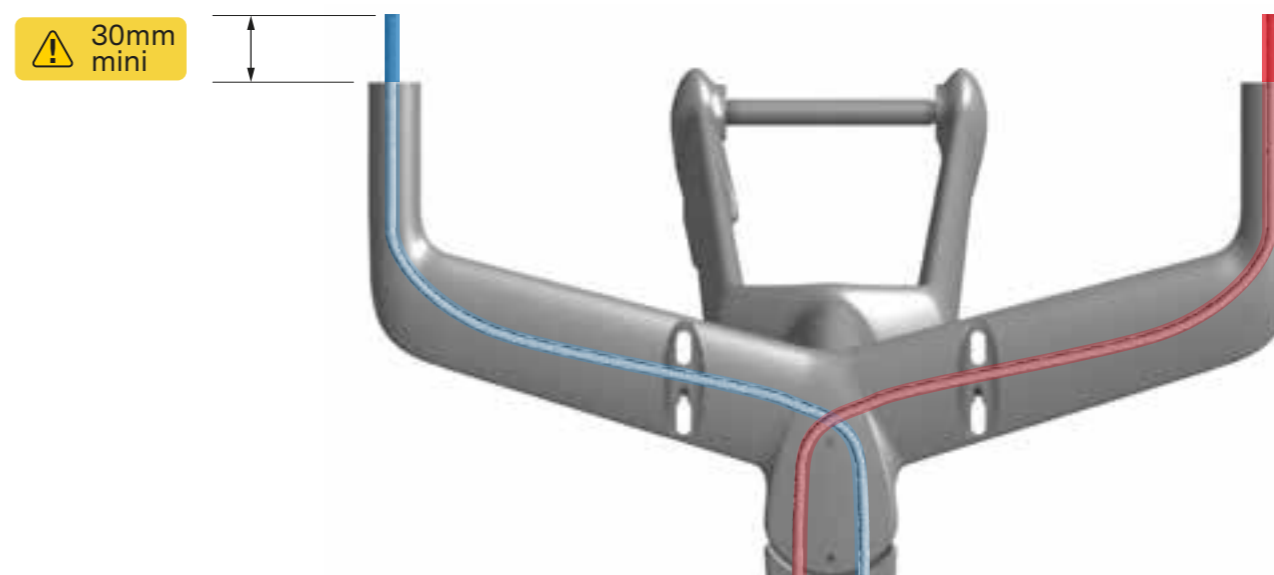

Cut the brake lines leaving at least 30mm of hose. This will make the lever installation easier and it will help you when removing the base bar for transportation.  
Install the brake levers following the manufacturer's instructions.

## Armrest risers, armrests and extensions assembly

### Stack height

Depending on your defined position (armrest stack), you can pick and prepare the appropriate set of spacers and bolts.

You can stack up to 65mm each 5mm increment. Parts illustrated in purple are parts you can choose to use to adjust your armrests stack.

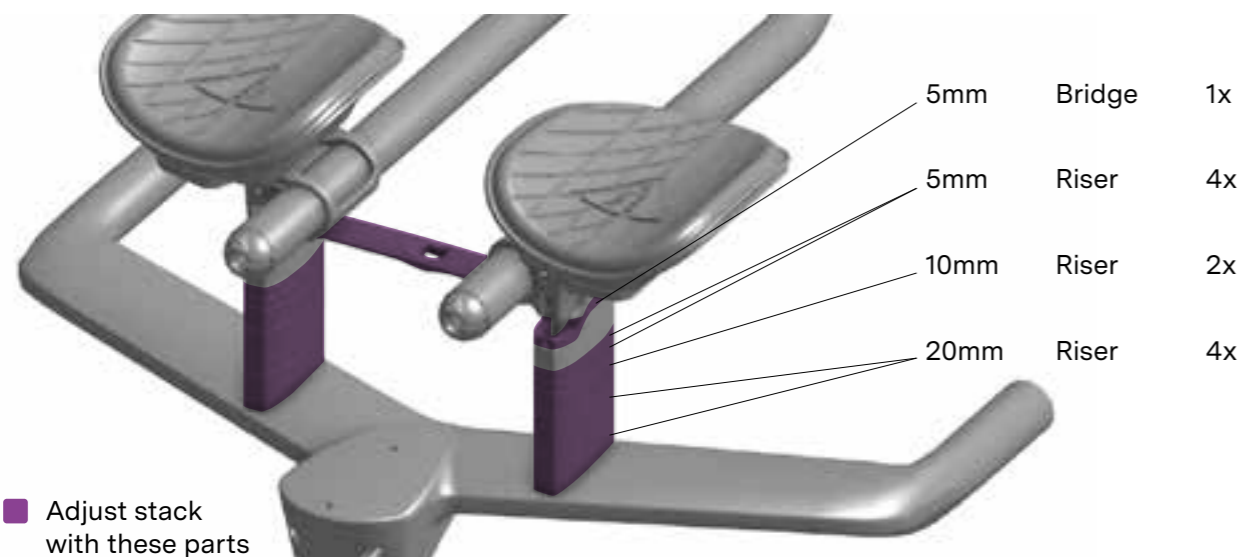

Follow the table below to select the right set of bolts and spacers to match your wished stack.

Spacer Stack [mm]	Bridge (5mm)	Front bolt length [mm]	Rear bolt length [mm]
0	NO	35	30
5		40	35
10		45	40
15		50	45
20		55	50
25		60	55
30		65	60
35		70	65
40		75	70
45		YES	80
50	85		80
55	90		85
60	95		90
65	100		95

**WARNING:** We strongly recommend to use the bridge from 45mm stack height. It will bring additional stiffness and stability.

**WARNING:** The front and rear bolts have different length. Please respect the table below to assemble the correct length.

- Pile up the required spacers
- Apply grease and Friction paste where indicated on the illustration below.

- Thread locker
- Friction paste
- Grease
- Align

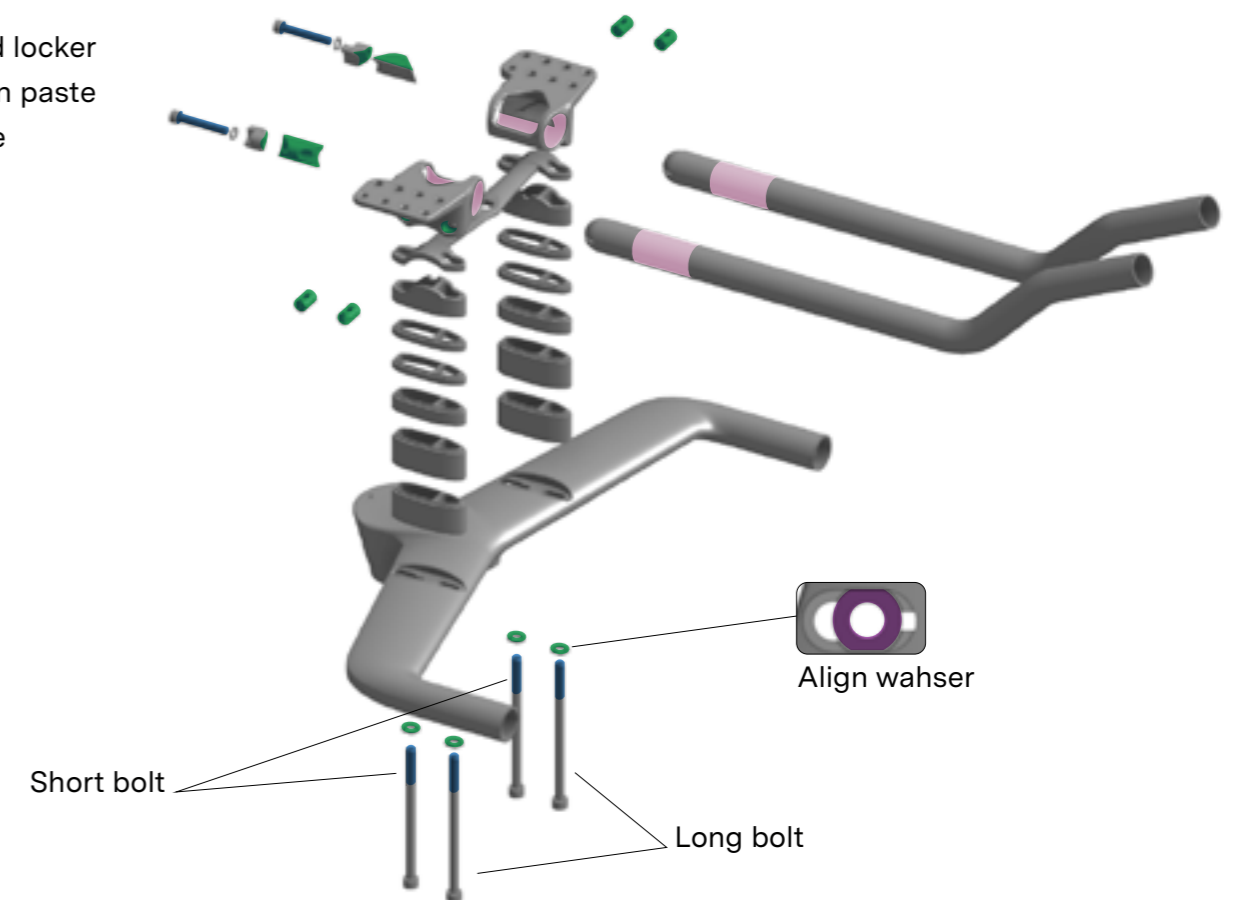

- Place the barrel nuts into the adapter following the right orientation
- Chamfered barrel nut to the front
- Slotted side on the outside

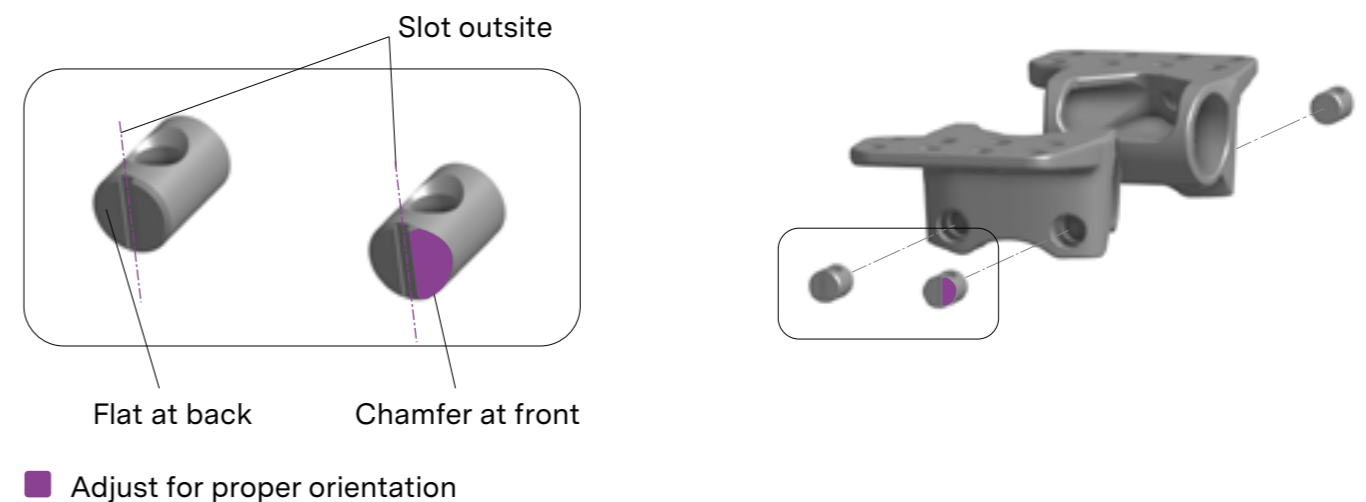

- Install the 4 bolts making sure the longest one is at the front.

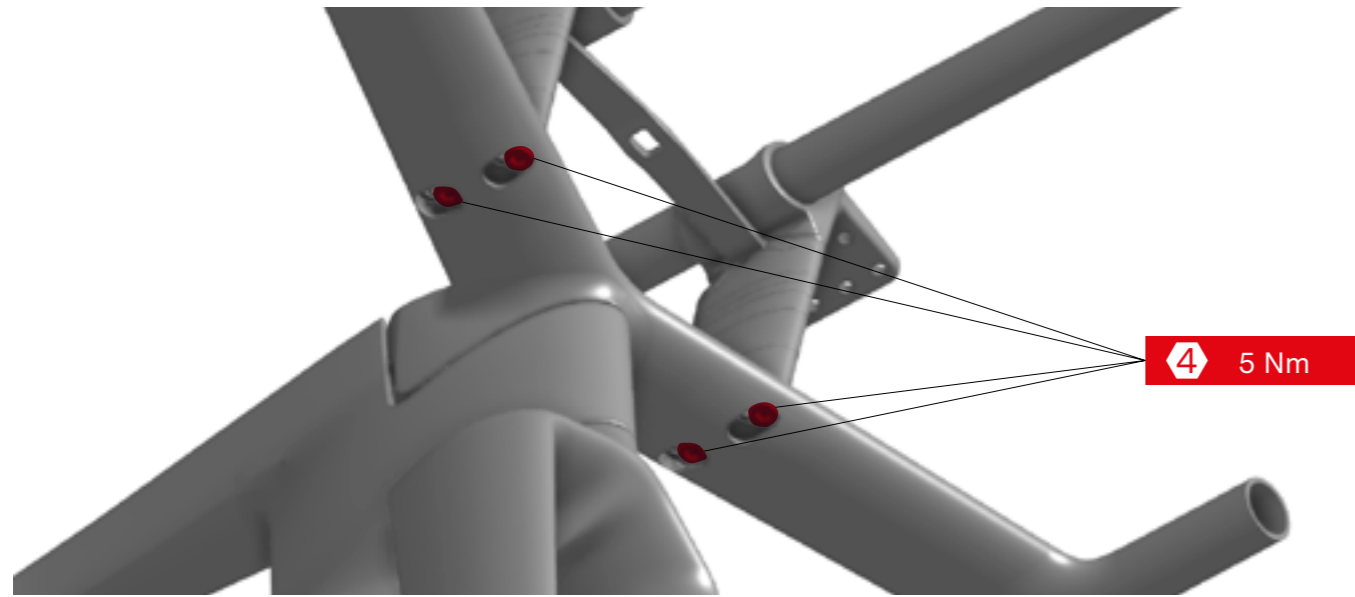

- Tighten to 5 Nm using a hex 4mm wrench.

**Tilt**

By adjusting the front and rear bolts, you can adjust the tilt of the entire armrest assembly from 0° (horizontal) to -15°.

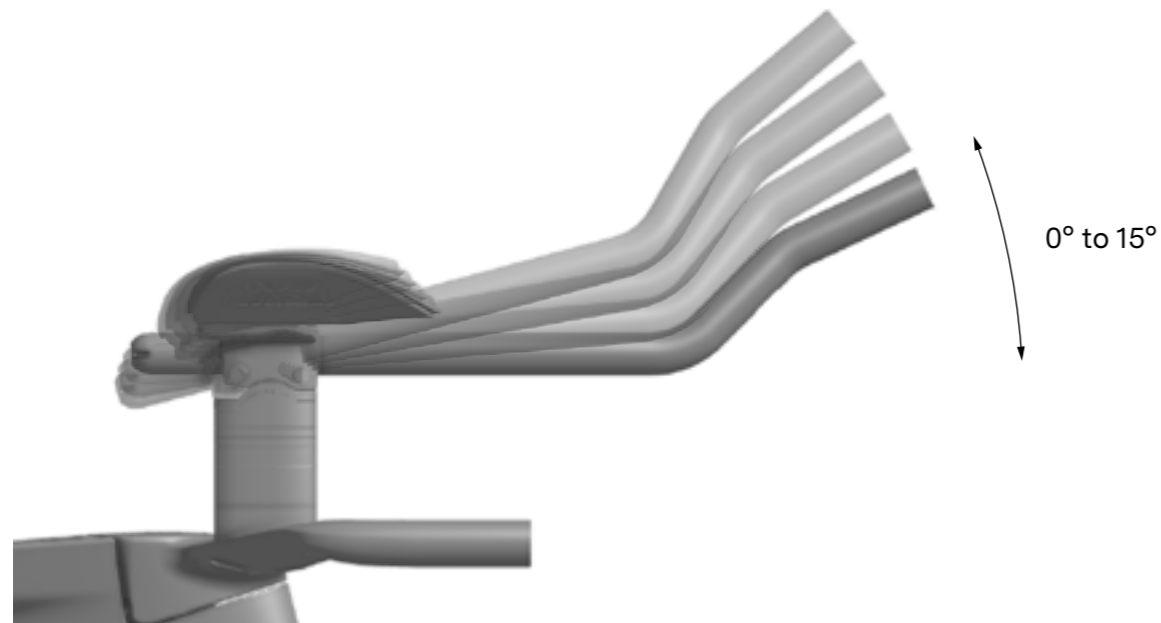

**Armrest installation**

- Select the armrests position:
- Fore and aft adjustment: 45mm in 15mm steps
- Width adjustment (c2c): 124, 142, 161, 179, 198, 216, 235, 253mm

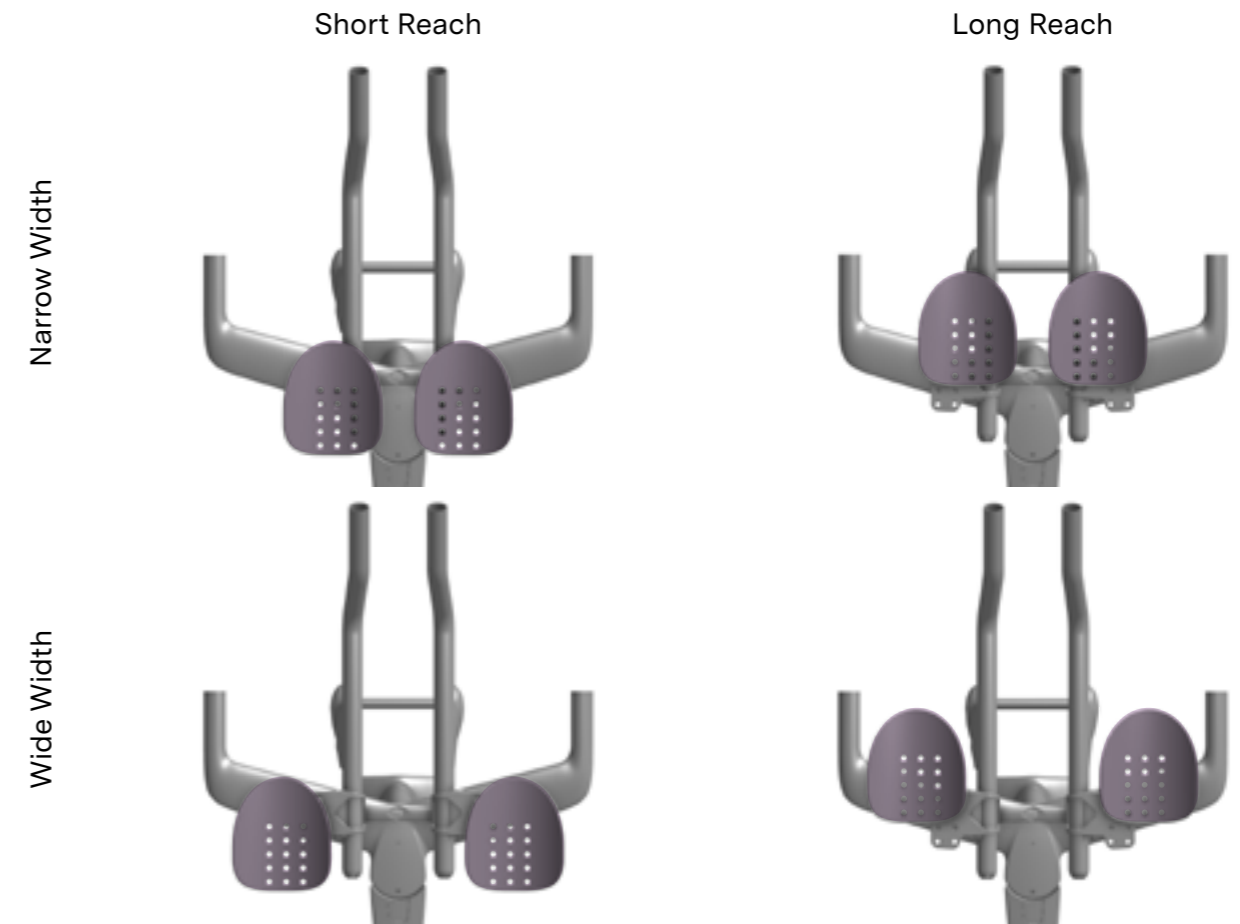

■ Armrests placement options

**ⓘ INFORMATION:** You could invert left and right armrests to tune the armrest width.

Resulting width ranges are:

- Standard: 142, 179, 216, 253
- Reversed: 124, 161, 198, 235

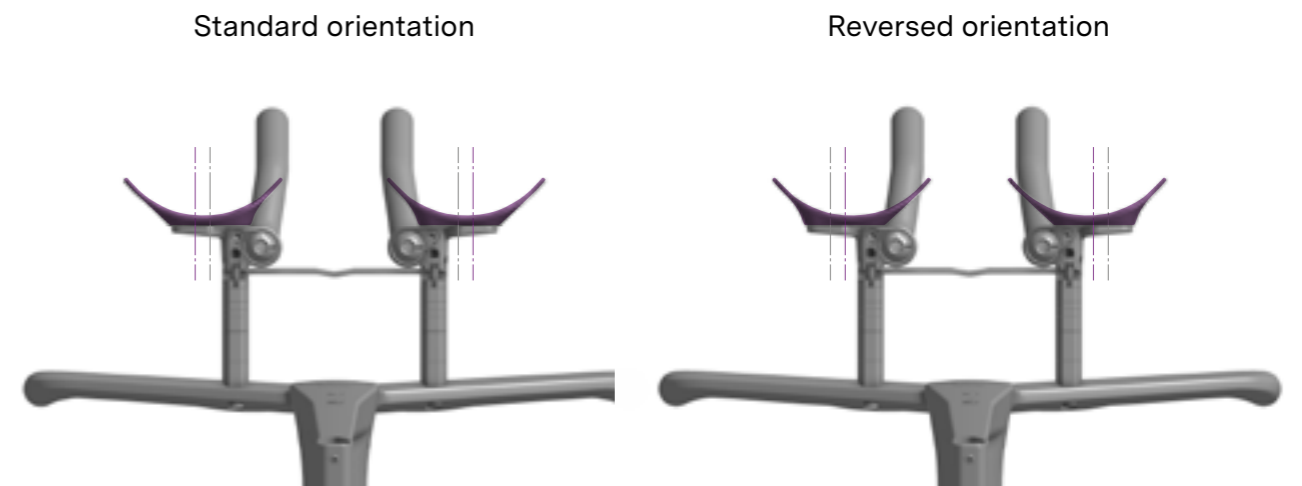

■ Armrests placement options

**⚠ WARNING:** The armrests are not designed to be used in the reversed position. Respect the orientation illustrated below.

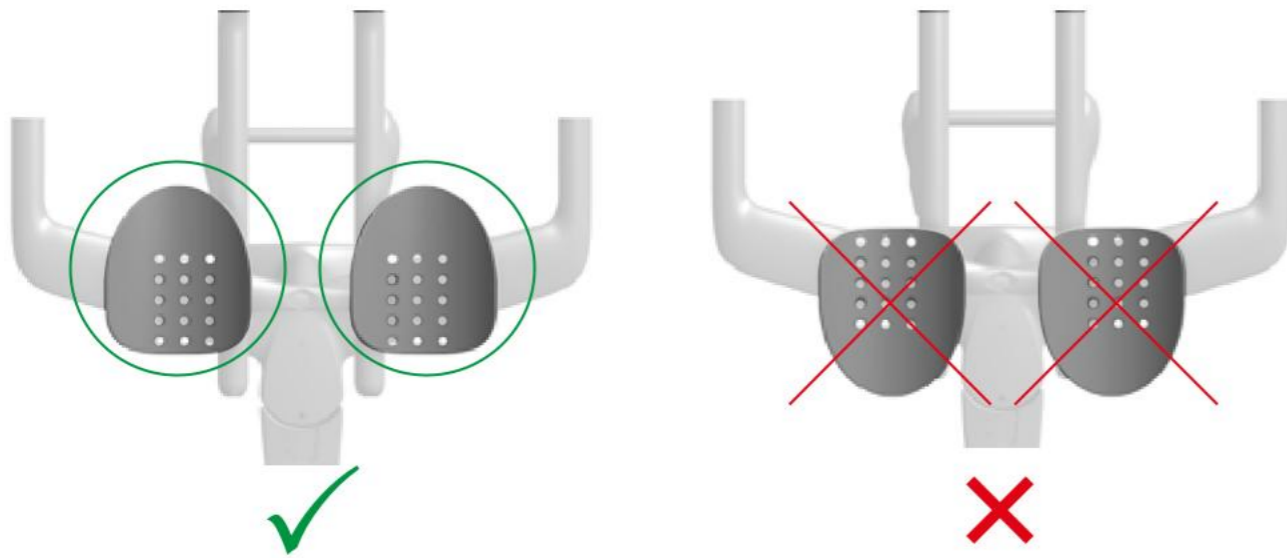

**⚠ WARNING:** Bolts orientation is preferred like described in the illustration below. This orientation gives a better structural stability to the armrests.

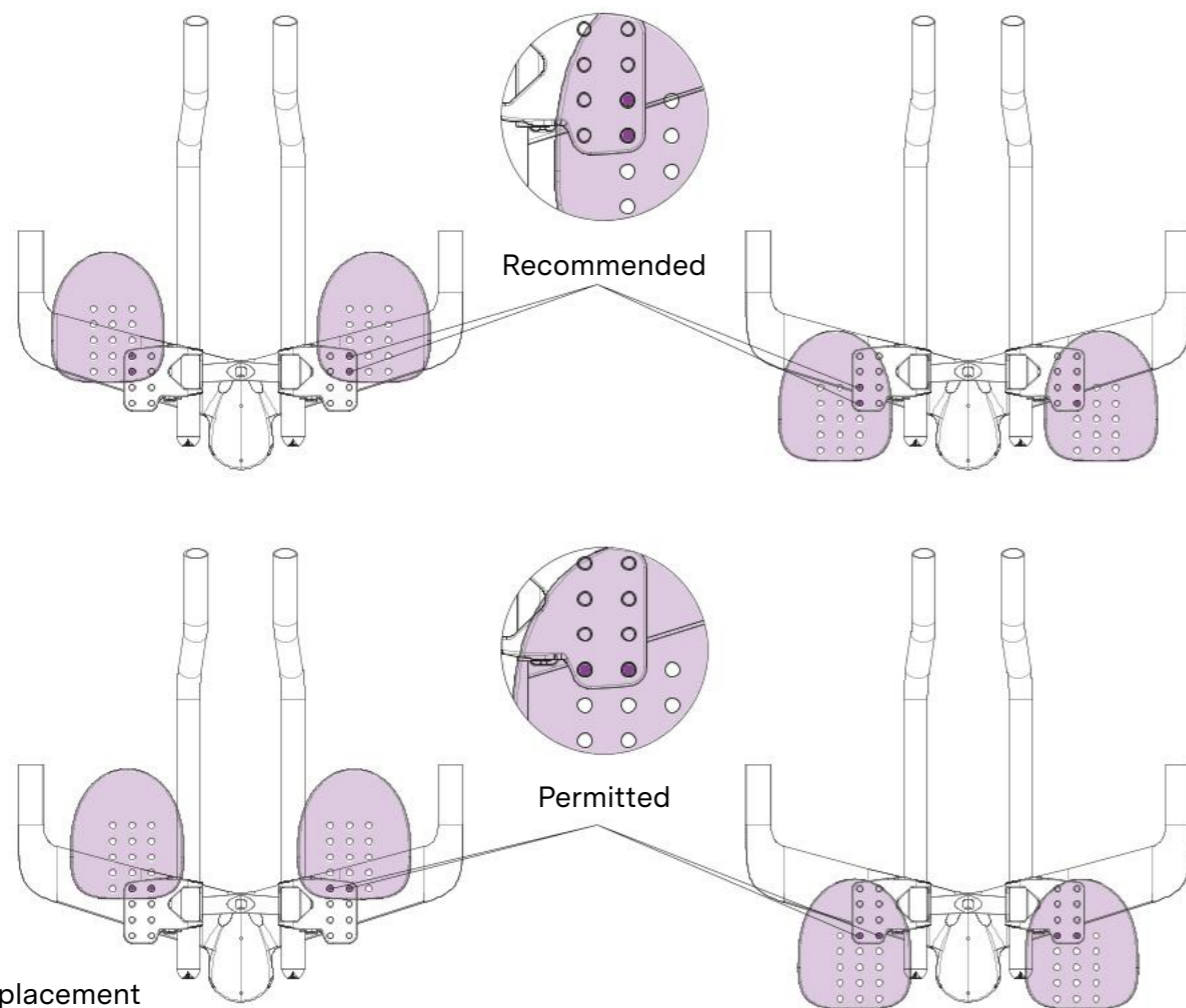

■ Bolts placement

- Thread locker
- Grease

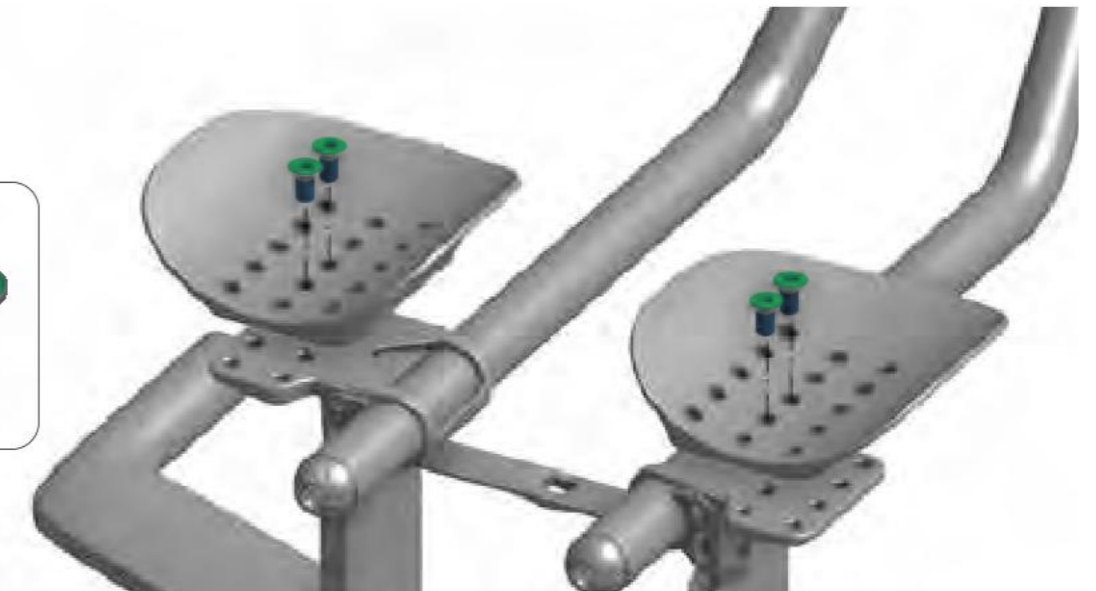
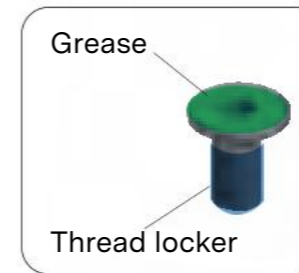

• Grease the 4 armrest bolts upper surface to reinforce their protection against corrosion.

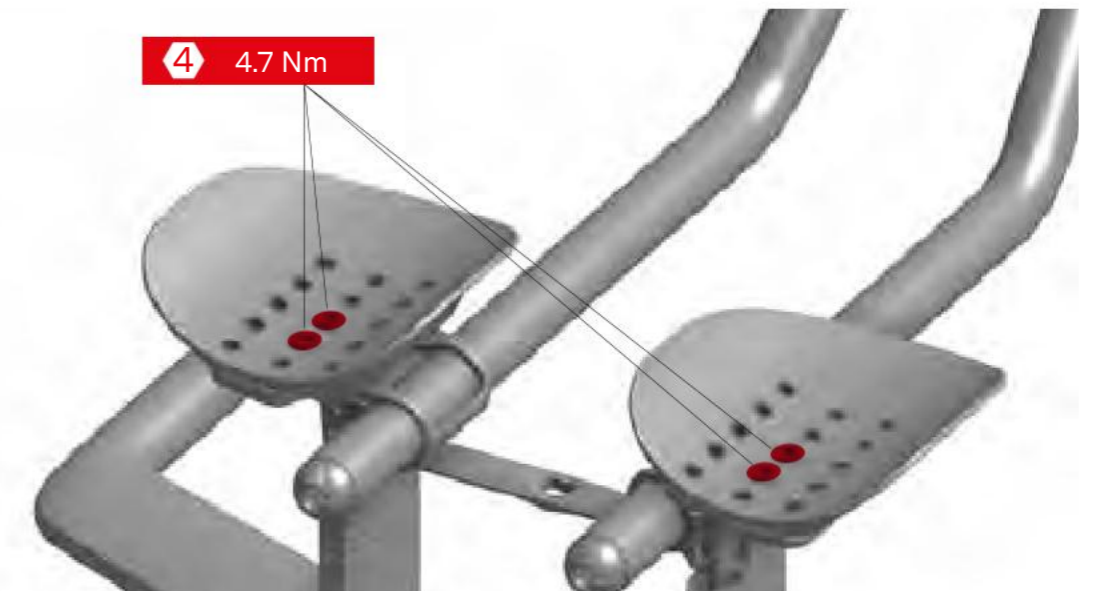

• Tighten to 4.7 Nm using a hex 4mm wrench.

### Pads installation

- Install the pads by placing carefully on hook and loop backing of the armrest and hold firmly for 30 seconds. Repeat for the other pad.

**ⓘ INFORMATION:** Note that the pads are symmetric and it doesn't matter which side pads are applied to.

- Align and press 30 sec

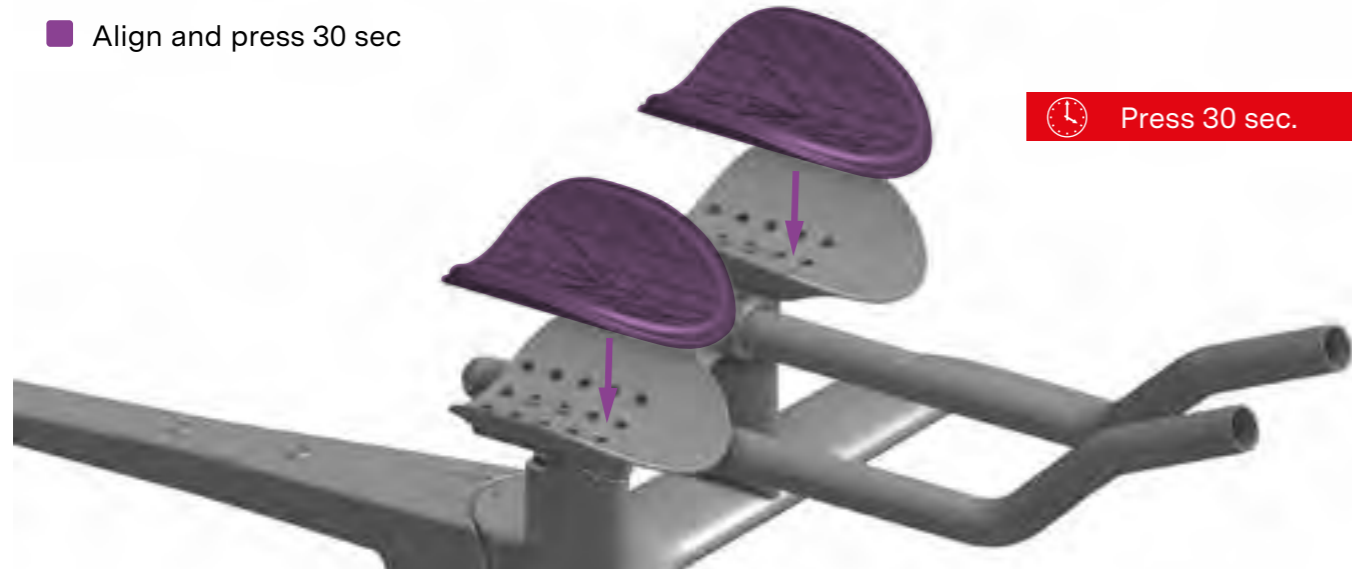

### Extensions installation

The Speedmachine is delivered with the popular extension “45/25 SLC Aerobar Extensions 400mm”

**ⓘ INFORMATION:** The extension diameter is Ø22.2mm. Therefore, other Profile Design extensions or other Ø22.2mm extensions are compatible.

- Apply grease and Friction paste where indicated on the illustration below.

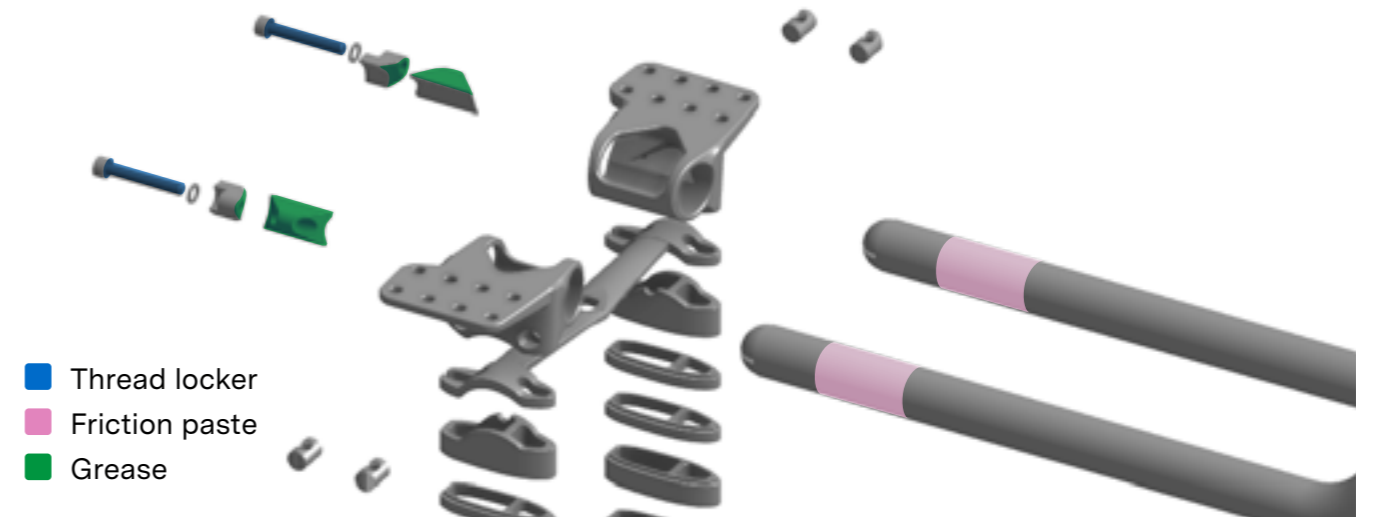

- Install the extension clamps
- Slide the extensions and orient them to the desired position

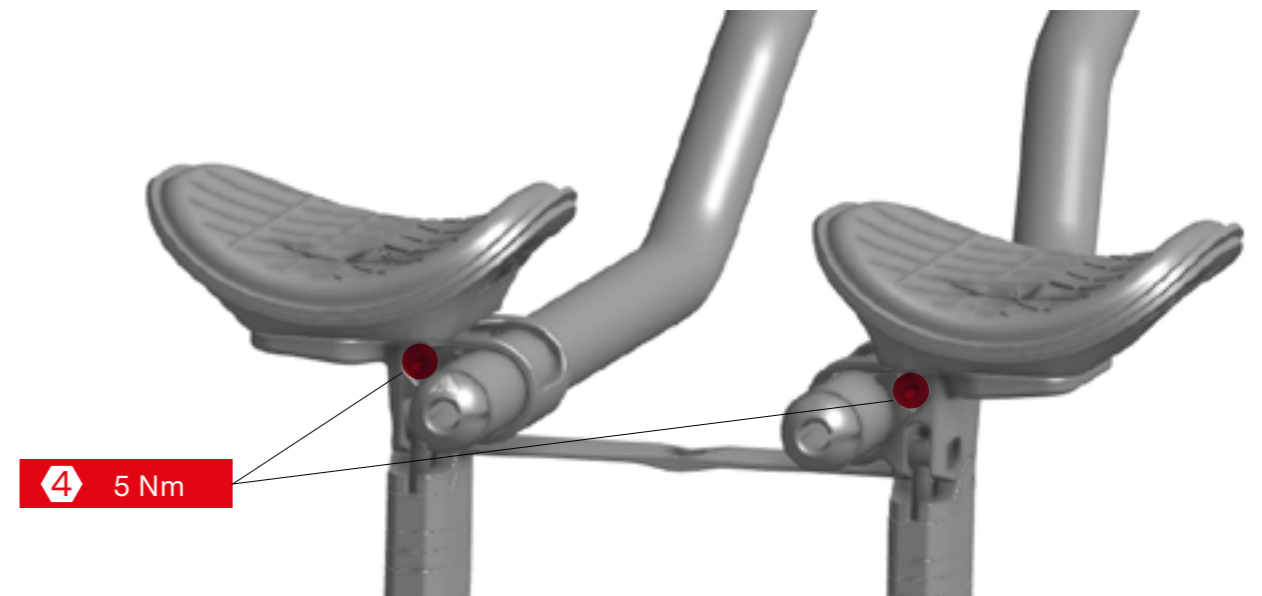

- Tighten to 5 Nm using a hex 4mm wrench.

## FuelTank installation

- Install the FuelTank clip using the 2 M4x16 bolts.
- Grease the 2 bolts upper surface to reinforce their protection against corrosion.

**⚠ WARNING:** Do not install the down tube or seat tube bolts.

- Thread locker
- Grease

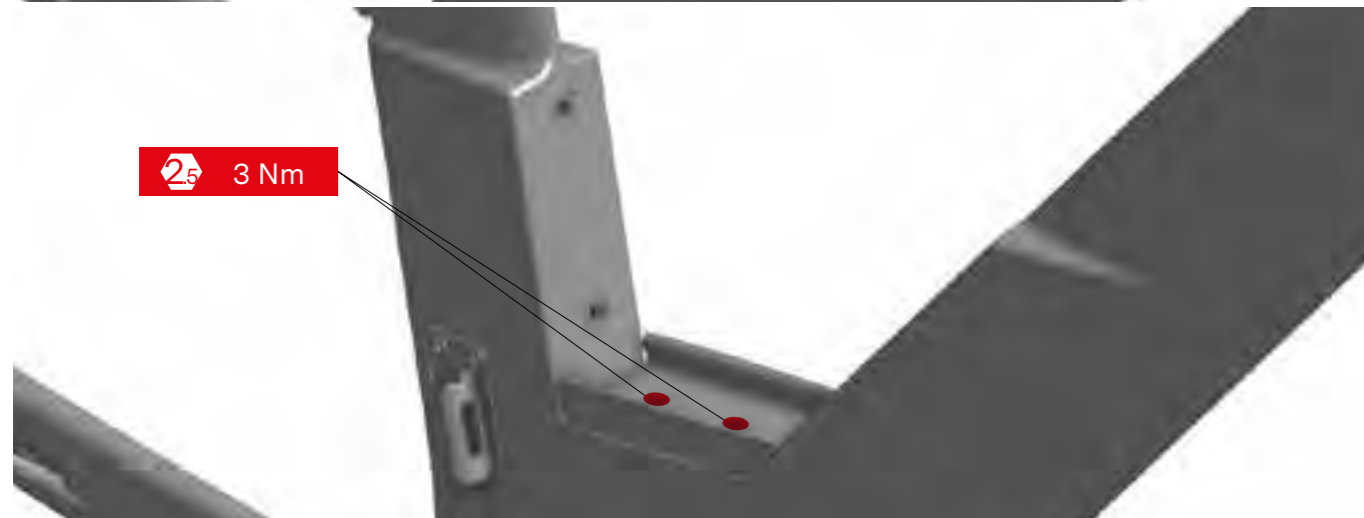
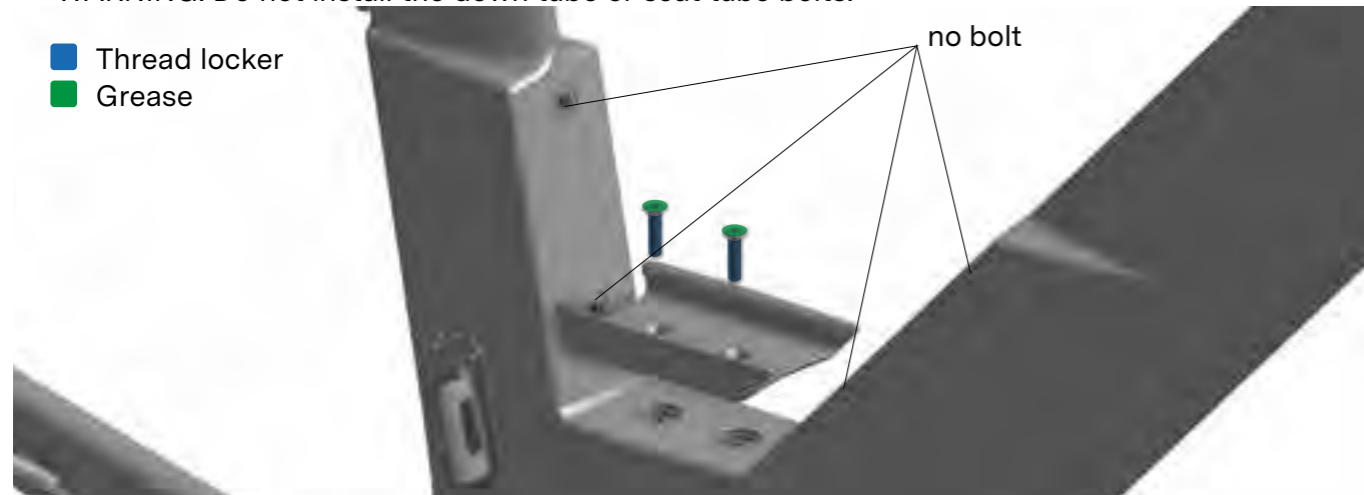

- Tighten to 3 Nm using a hex 2.5mm wrench.
- Install the FuelTank by sliding it over the clip and pressing it down firmly until you feel it snap into the clip.

- Push down firmly to clip in

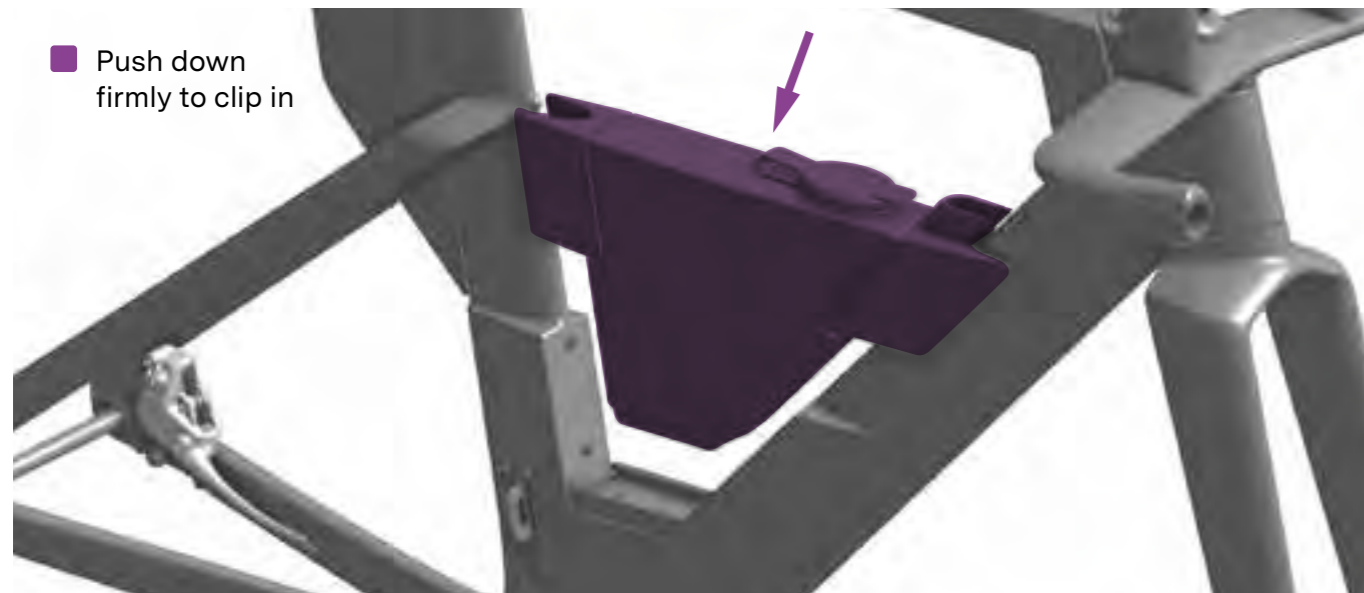

- Route the straw into the FuelTank pushing it enough to reach the bottom of the FuelTank.

- Slide to the bottom of the Fueltank

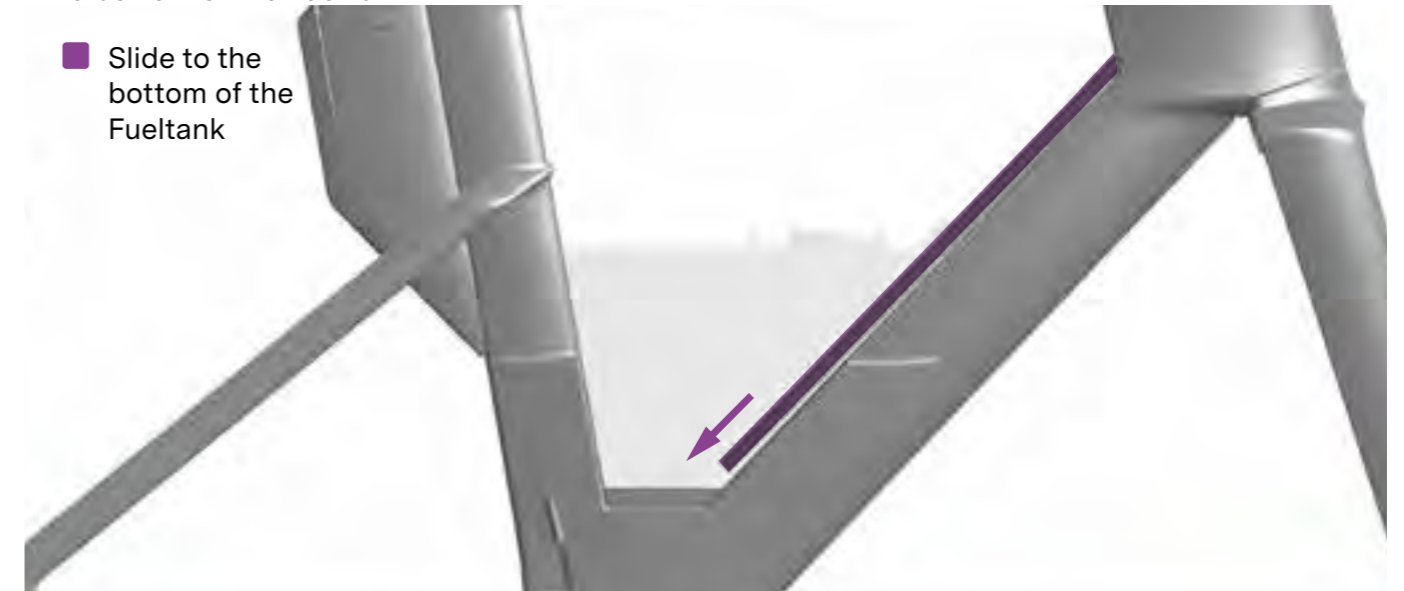

- Route the straw through the top tube cap.

- Slide the straw into the top tube cover

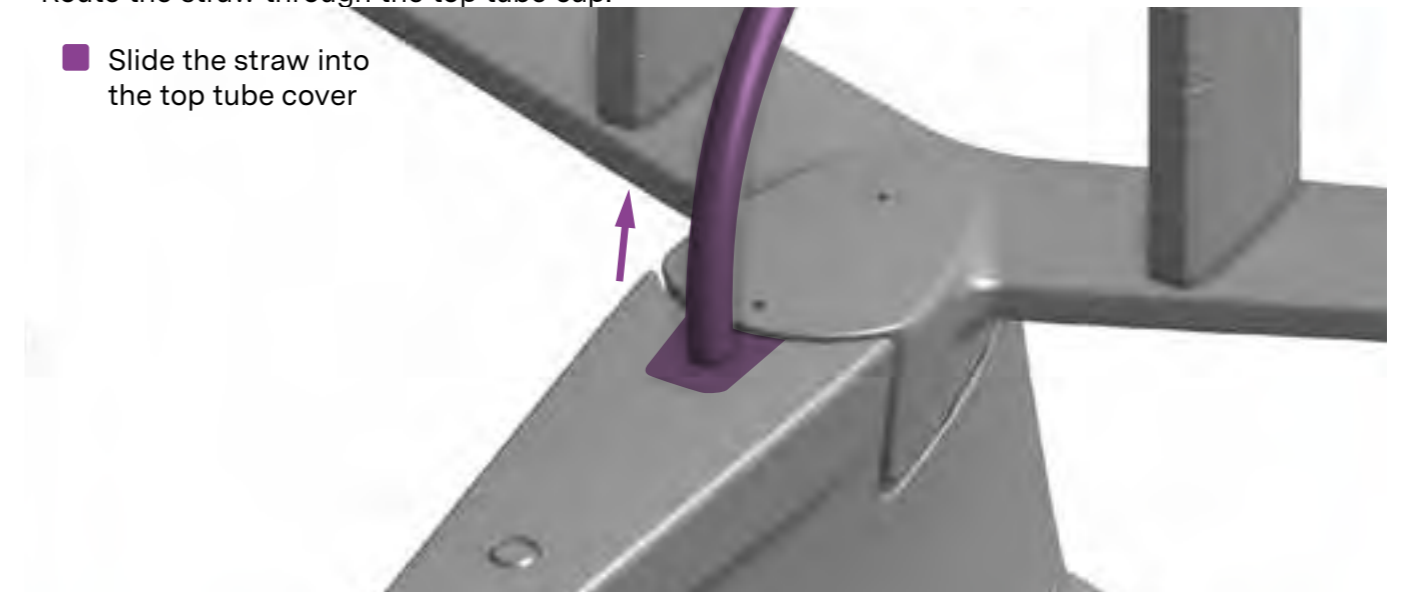

- Slide the magnet on the straw
- Attach the magnet to one of the extension using a zip tie

- Install magnet on one of the extension

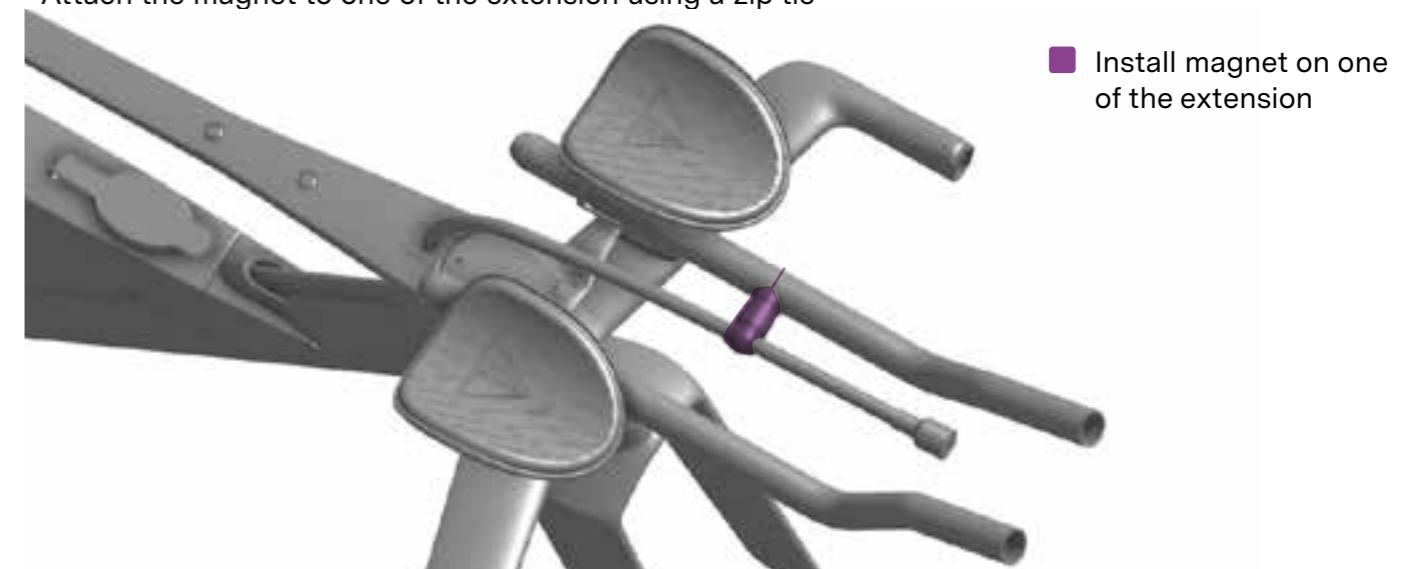

- Slide the bite valve into the straw

## Water bottle installation

- Install the TT Bottle slider using 2 M5x12 bolts.
- Grease the 2 bolts upper surface to reinforce their protection against corrosion.

- Thread locker
- Grease

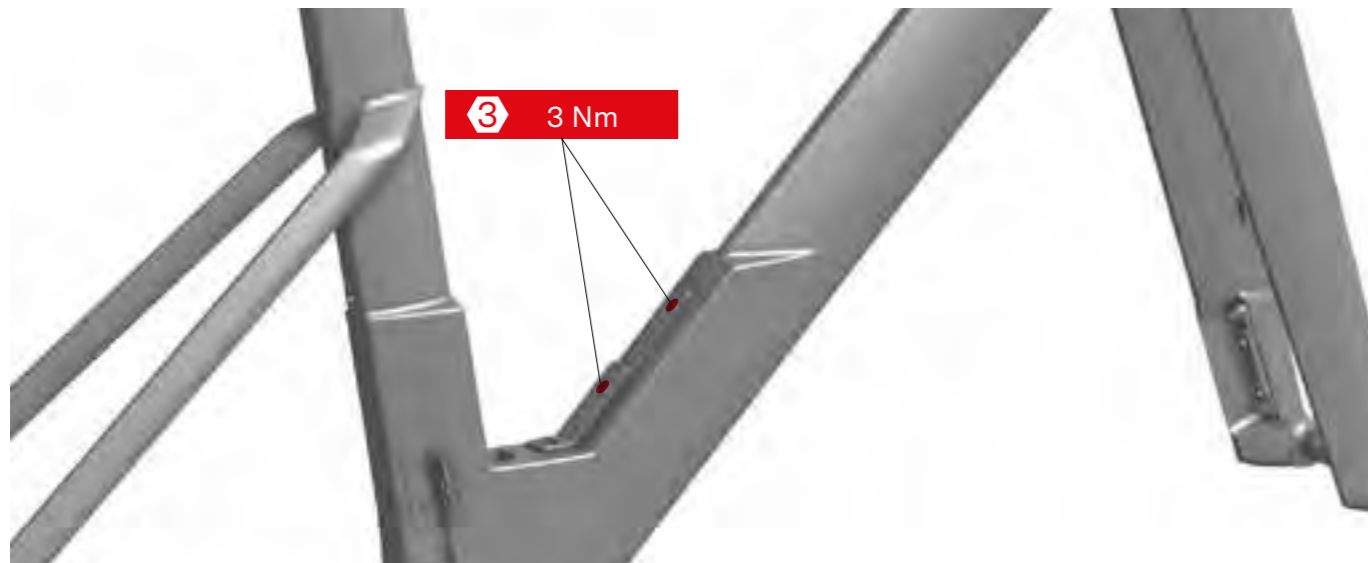
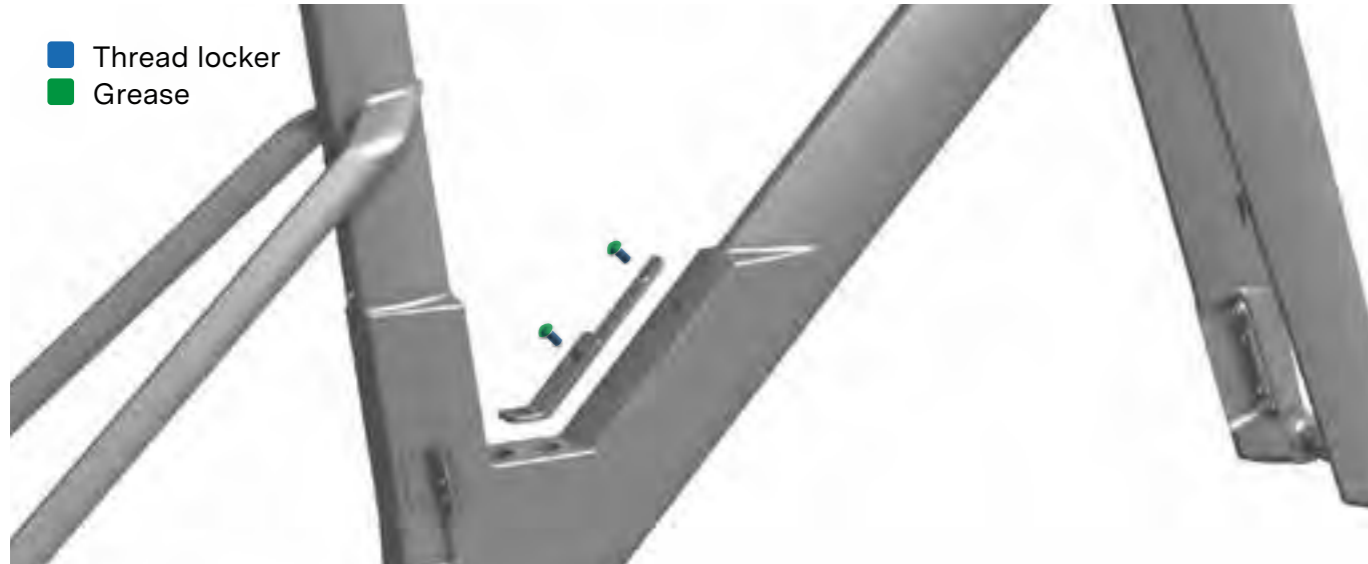

- Tighten to 3 Nm using a hex 3mm wrench.

Install the water bottle by sliding it over the rail.

- Slide down

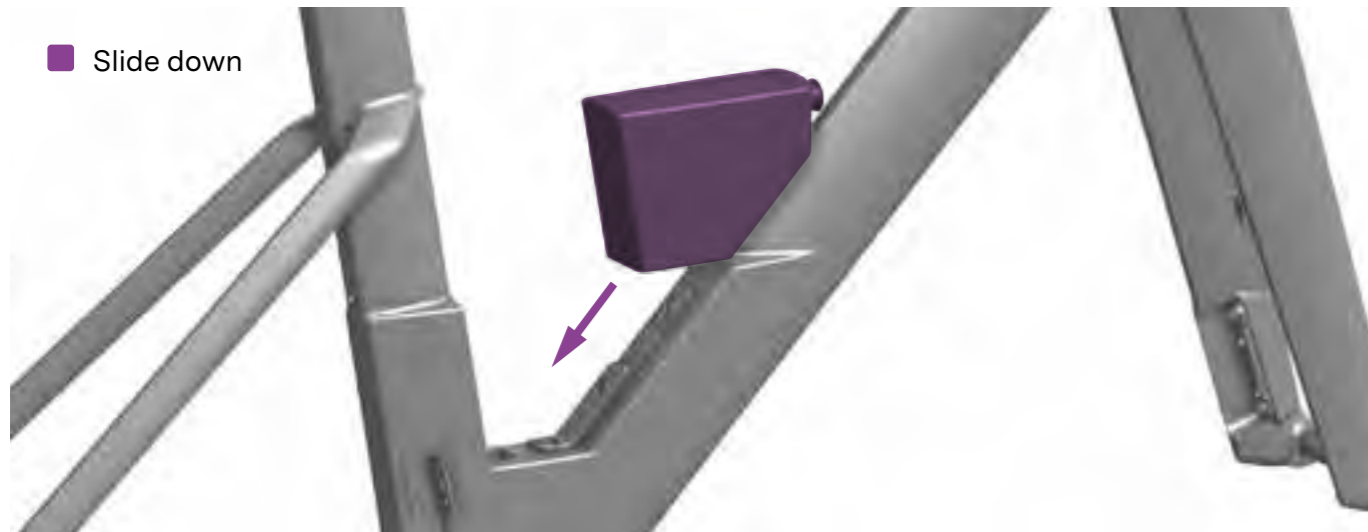

## Top tube storage

The Speedmachine is equipped with top tube threads to allow the mount of a top tube storage.

The top tube storage threads are covered by plugs.

**⚠ WARNING:** Do not exceed a torque of more than 5Nm with the top tube storage bolts.

- Remove plugs to access top tube mounts

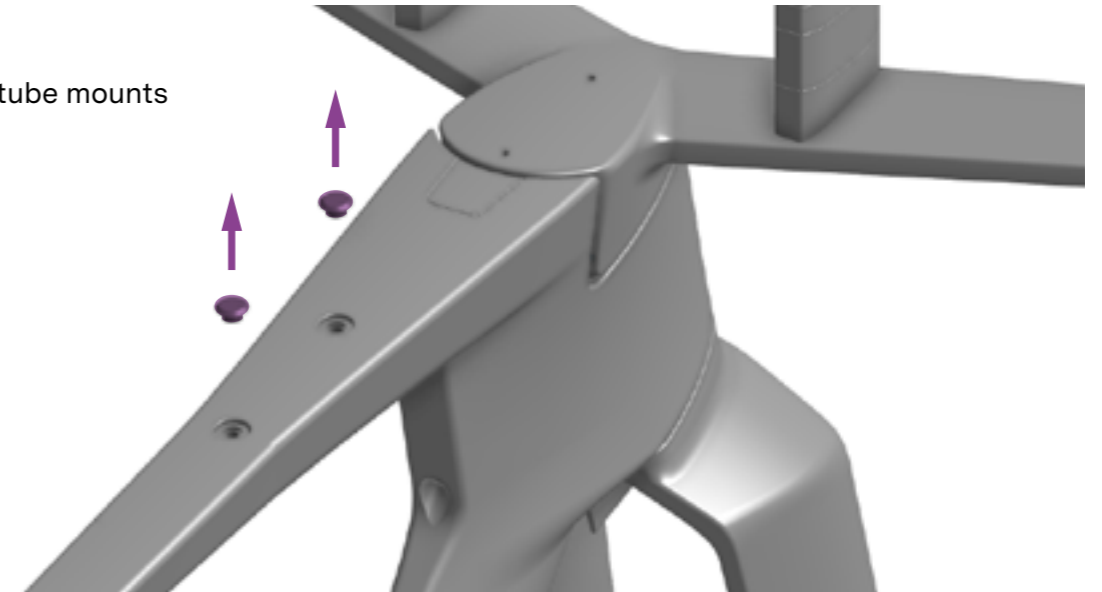

## Wheels and axles

**⚠ WARNING:** Your bike is delivered pre-assembled with inner tubes for transportation and display.

Always setup the wheels following the recommendations and instructions of the wheels and the tire manufacturers:

- Some wheels must only be assembled in tubeless
- Some wheels must only be installed with specific tires for a tubeless setup (hookless rims)
- Even if the wheels are tubeless, some tires assembled on some bike models may not be tubeless
- Please read carefully the tires and the wheels instructions.

**⚠ WARNING:** Make sure the tubeless compatibility is insured between your wheels and your tires:

- Minimum and maximum tire size
- Minimum and maximum tire pressure
- Tire bead design (hooked or hookless)
- Rim design (hooked or hookless)

- Grease the thread and the head of the thru-axles.

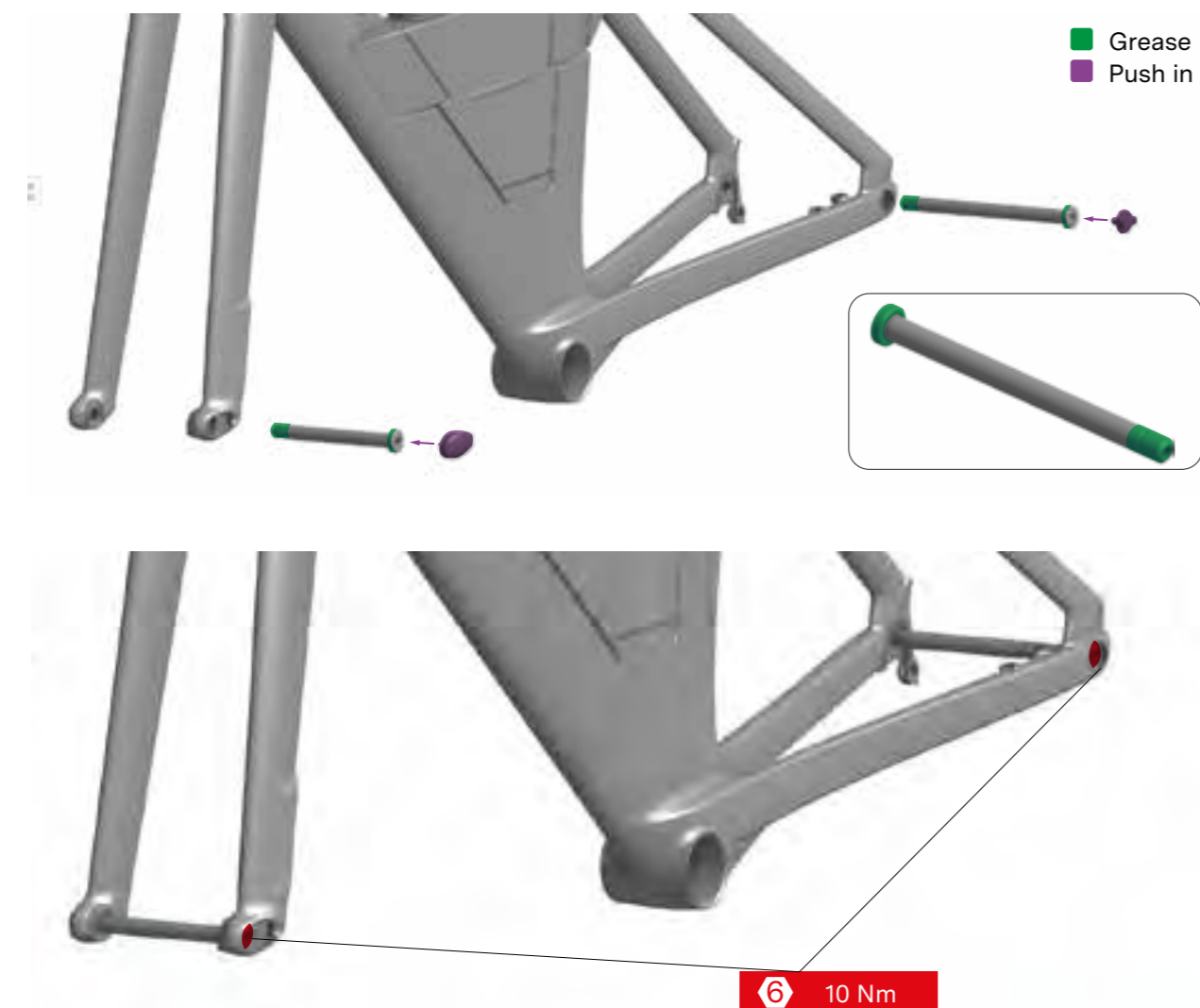

- Through axles have to be torqued to 10 Nm using a hex 6mm.
- Once installed, you can plug the rubber aero caps into the fork and the rear dropout.

## Service instructions

The BMC Speedmachine is a high-tech, performance oriented product. We ask you to specially take care of your bike if you want it to deliver the maximum of its performance over the years.

If you notice parts that are worn out or damaged, do not hesitate to replace the part and or contact your BMC dealer.

### Washing your bike

You should never use high pressure washing device to clean your Speedmachine. The integrated components of the bike were designed to be integrated and aerodynamically efficient, they were not designed to be water-tight at high pressure. We recommend to use a brush and soft bike soap, and rinse with water at low pressure.

Avoid degreaser and brake cleaners directly on the frame, fork and base bar. Composite carbon and painted components could be permanently damaged and fragilized.

### After washing

If there is water trapped in your frame, it should drain automatically from below the bottom bracket.

If the steering does not rotate freely, check the installation of the base bar. If the issue is not solved, it may be that your headset bearings need to be replaced.

If your seatpost makes unusual noise after washing or riding in wet weather, you need to take the seatpost apart, clean the frame seat tube and the seatpost, and reapply carbon friction paste between frame and seatpost.

### Trouble shooting

#### Noise from the saddle or the seatpost:

- Apply friction paste between the seatpost and the frame seat tube.
- Apply grease on each element of the saddle clamp (bolt, washer, clamps).
- Apply friction paste between the seatpost shaft and the frame.

#### Noise from the drivetrain:

- Check front and rear derailleur assembly and front and rear dropout hangers assembly. Reapply thread locker compound on the dropout hanger bolts if necessary and tighten to torque.
- Check rear thru axle: clean with a degreaser, reapply grease on thru axle like indicated in this manual and reassemble tightening to torque.
- Check bottom bracket and crankset following instructions from their manufacturer(s).

#### Seatpost slipping down:

- Apply friction paste between the seatpost and the frame seat tube
- Control the torque at the seatpost clamp and at the saddle clamp.

#### Play in the headset:

- Remove the base bar, and tighten lightly the headset bolt to 4Nm.

#### Friction in the headset:

- Make sure nothing is stuck in between head tube and fork or between the base bar and the head tube.
- Control the headset bearings and replace them if necessary.

#### Play in the extensions or base bar:

- Do not ride with play in the cockpit assembly.
- Control the torque settings of every single bolt.
- Apply grease, thread lock and friction paste as indicated in this manual.
- Control that none of the stem bolt is damaged.



**BMC**