

# Teammachine SLR

Owner's Manual

***BMC***

MEMBER

# Table of content

<b>Introduction</b>	<b>5</b>
<b>Generalities</b>	<b>5</b>
General Notes And Warnings	5
Intended Use	6
Bike Registration And Warranty Extension	6
General Notes About This Manual	6
Before We Start	6
Component Compatibility	7
Special Parts Details	8
General Notes About Assembly	17
Repair Stand	17
Torque Specifications	19
Recommended Assembly Procedure	21
<b>Sizing and Parts Selection</b>	<b>22</b>
Positioning	22
Frame Size	23
<b>Detailed Assembly Instructions</b>	<b>25</b>
Frame Preparation	25
Electronic Wires Installation	28
Seatpost Assembly	30
Fork, Headset and Cockpit Preparation	33
Definition of Steerer Tube Length	36
Brake Calipers Assembly	40
Shifting Cables Assembly	44
Headset, Top Cone and Spacers Assembly	46
Cockpit or Stem Installation	48
Headset Compression and Clamping the Stem	51
Bottom Bracket and Crankset Assembly	52
Bottle Cages	52
Wheels and Axles	53
Fenders	54
<b>Service Instructions</b>	<b>57</b>
Washing Your Bike	57
After Washing	57
Trouble Shooting	58
<b>Notes</b>	<b>59</b>

MEMBER

# Introduction

The Teammachine SLR represents the pinnacle of functional integration, and rider-focused fit. By patiently following these guidelines, the content of this manual will lead to properly fitting and functioning equipment with a high-performance, Swiss Engineered aesthetic.

BMC Teammachine SLR frame and components are designed as a system to provide a very high level of performance. It uses all the latest and most high-end technologies that can be found in bicycle manufacturing, including thin-walled carbon fiber composite construction, which should be treated with care by the end user to prevent permanent and sometimes invisible damage.

For the reasons mentioned above, we ask you to carefully follow the instructions provided in this manual.

Incorrect mechanical operation on your bicycle could lead to serious damage, which could cause you to fall and lead to injury or death.

If you do not have the appropriate tools or experience to execute the following instructions, or if you need further information, please contact your official BMC dealer for service of your bicycle.

## Generalities

### General Notes And Warnings

You must read and understand the Safety Instructions described in the BMC Owner's Manual included with your product before proceeding with installation. Improperly installed components are extremely dangerous and could result in severe and/or fatal injuries. If you have any questions about the installation of these components, consult a qualified bicycle mechanic.

 **WARNING:** Indicates a dangerous or hazardous situation. Not respecting the instruction could result in losing control of the bike or having a component fail. Consequences could be: product damage, injury or death.

 **INFORMATION:** Indicates important information.

This manual uses icons and color codes to indicate actions for proper assembly and adjustments.

 Grease	 Torque
 Thread locker	 Adjust
 Friction Paste	 Measure

## Intended Use

The Teammachine SLR is designed and tested for Road riding.

It complies with Level 1 ASTM Classification.

Please read and refer to the general BMC Owner's Manual for more details.

The structural weight limit for the Teammachine SLR is 110kg / 242lb.

**⚠ WARNING:** Always make sure to never exceed the structural weight limit with the sum of rider weight, rider's equipment (e.g., helmet, shoes, apparel) and nutrition (e.g., water, energy gels and bars). Exceeding the structural weight limit may impair the structural integrity of the bike and result in component damage or failure.

## Bike Registration And Warranty Extension

BMC provides a voluntary warranty on the frame, and on BMC components and paintwork. By registering your Teammachine SLR within the first six months after initial purchase on the Bike Registration page ([www.bmc-switzerland.com/bmc-bike-reg](http://www.bmc-switzerland.com/bmc-bike-reg)) or within the BMC Companion App, you can extend the warranty on the frame to five years. You can read the warranty provisions in detail on the Warranty policy page ([www.bmc-switzerland.com/warranty](http://www.bmc-switzerland.com/warranty)).

## General Notes About This Manual

Read and keep this manual for your BMC Teammachine SLR Gen4.5. It includes essential safety, performance, and technical details. Refer to it before your first ride and store it in a handy place.

This document is specific to the Teammachine SLR Gen4.5 and should be read with the "BMC Operating manual".

## Before We Start

A Teammachine SLR frameset or complete bike includes proprietary components such as seatpost, headset, thru-axles, stem ... For each of those components, you will find part numbers, service and assembly instructions detailed in the following chapters of this manual.

## Component Compatibility

### Brakes :

- Front: flat mount for 160mm rotor only using BMC specific front brake adapter.
- Rear: flat mount brake boss 25mm thickness, compatible with Ø140mm / Ø160mm rotor

For more details, please refer to “Brake Calipers Assembly”, page 40.

### Headset Bearings:

- BMC by FSA, HS-B-13P

For more details, please refer to “Headset Assembly”, page 46

### Thru-axles:

- Front: BMC model CTC0008-L2V7 12x100mm
- Rear: BMC model CTC0007-L2V7 12x142mm

### Shifting Compatibility:

#### Electronic groupsets

- Shimano 12s Di2, SRAM AXS, Campagnolo Wireless
- Not compatible with Campagnolo EPS

#### Mechanical shifting groupsets

- Mechanical shifting systems with front derailleur designed with integrated cable housing stop.
- Designed for road chainlines of 44.5-45mm.

For more details, please refer to “Electronic Wires Installation”, page 28.

### Tires:

- Optimized for tires between 700x24c and 30c (30mm measured)
- Min 700x20c (for minimum pedals-to-ground clearance)
- Max 700x30c: up to 30mm measured (+4mm clearance around the tire)

### Crankset and Chainrings:

- Press-fit bottom bracket BB86 (internal diameter of 41mm)
- Cranksets either 2x (double) or 1x (single)
  - 1x: 48t compatible
  - 2x: 52x36 or 50x34
  - Compatible for standard road chainline (not wide chainline)
  - Max chainring size (2x): 55t
  - Min chainring size: 31t

### Rack:

- No rack is compatible with the Teammachine SLR.

### Fenders

- Teammachine SLR: Some fenders with light fastening systems can be fitted onto the Teammachine SLR (SKS Speedrocker or RaceBlades)

# Special Parts Details

## Teammachine SLR - Frameset and Parts

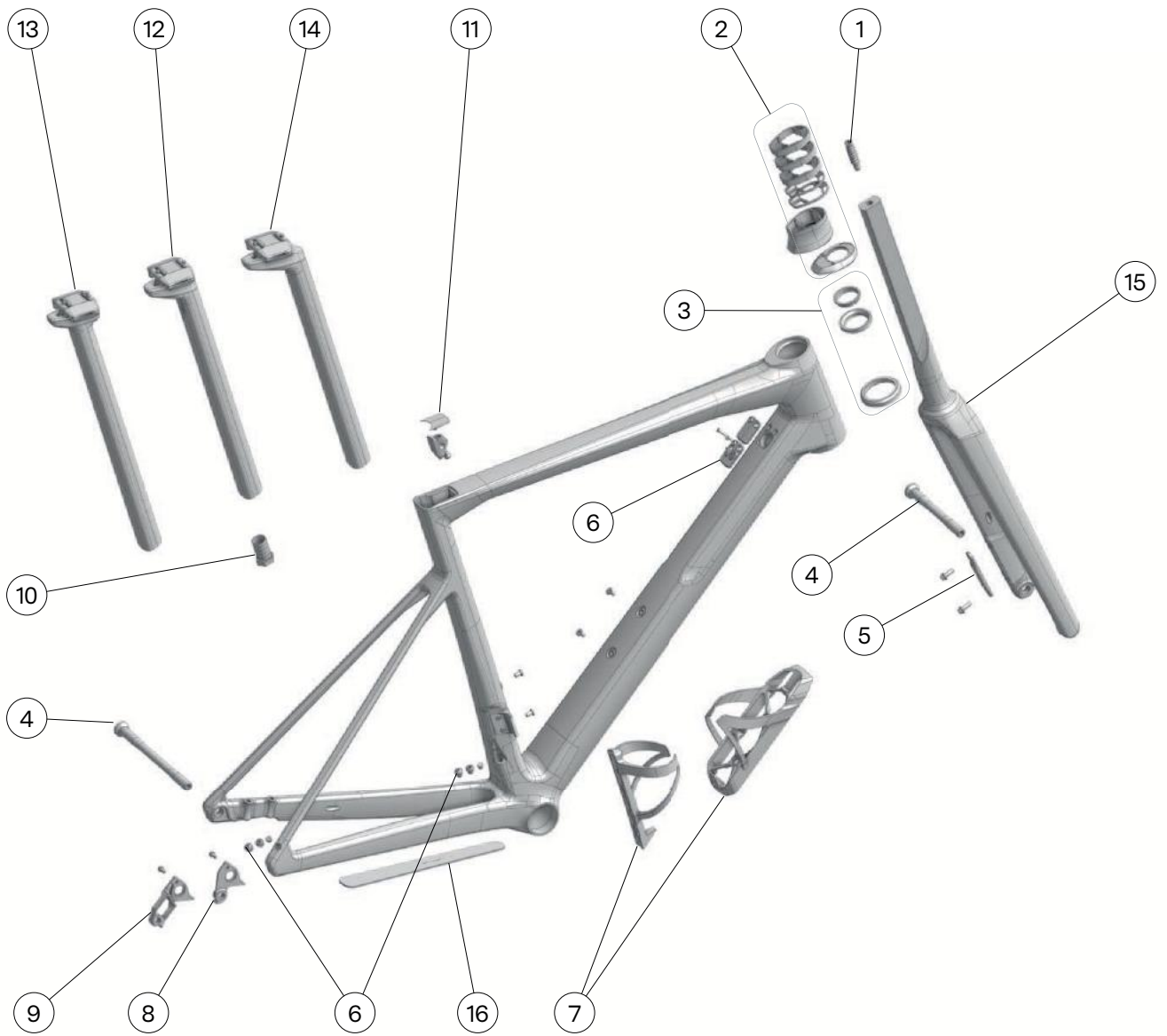

**NO. Description/Details**

- 1 Flat Steerer Expander Bolt, Incl. Top Cap Bolt
- 2 Topcone Set ICS2 ICS Carbon
- 3 HS B 13, Standard headset bearings
- 3 HS B 26, Ceramic Speed headset bearings
- 3 HS B 25, Stainless headset bearings
- 4 Axle Kit #7 Stealth, Front and rear thru-axle kit
- 5 Front brake caliper adapter
- 6 Cable Guide #27, Downtube cover, cable guide, bolts and rubber plugs
- 7 Aero Cage Set
- 8 Dropout #71 (SRAM/Campagnolo/Shimano Direct Attachement)
- 9 Dropout #72 (Shimano Direct Mount)
- 10 Shimano battery adapter for seatpost with foam core
- 11 SP CMP #26, Seat post clamp
- 12 Seat post SP SLR01 15mm offset
- 13 Seat post SP SLR01 0mm offset
- 14 Seat post SP SLR01 30mm offset

## Frame Hardware

### Fork Expander



**Article number:**

30007222 FSTR expander bolt, short Flat Steerer Expander Bolt, Incl. Top Cap Bolt

### Top Cones and Spacers Set



**Article number:**

30001801 TC Set ICS2, ICS CBN BLK SLR01 - Topcone Set ICS2 ICS Carbon

### Headset Bearings Set



**Article number:**

30000704	HS B 13	Standard headset bearings
30007614	HS B 27	Stainless headset bearings

### Thru-axles



**Article number:**

30000699 Axle Kit #7 Stealth Front and rear thru-axle kit

---

## Front Brake Adapter

**Article number:**

30000714 BRK Mount ADP SLR01 SLR Front  
brake caliper adapter

---

## Downtube Covers and Rubber Plugs

**Article number:**

30000713 Cable Guide #27 Downtube cov-  
er, cable guide, bolts and rubber plugs

---

## Bottle Cages Set (optional)

**Article number:**

30000698 Aero Cage Set

---

## Rear Dropout Hangers

**Article number:**

30000700 Dropout #71 SRAM/Campagnolo/  
Shimano Direct Attachement

**Article number:**

30000701 Dropout #72 Shimano Direct Mount

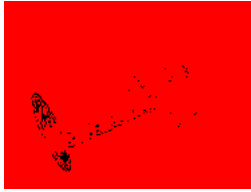
**Battery Adapter****Article number:**

212500 Internal Battery Adapter Shimano  
battery adapter for seatpost with foam core

---

**Seatpost Clamp****Article number:**

30000702 SP CMP #26  
Seatpost Clamp No. 26

---

**Chainstay Protector****Article number:**

30007621 CNST PRT No. 22 Chainstay pro-  
tectors. Set of 1 clear gloss and 1 clear satin

---

## Stems & Cockpit

The Teammachine SLR frameset is designed for more versatility and is compatible with different types of cable routing. It is compatible with ICS type cockpits and stem, internal brake cable routing, internal or external shift cable routing.

	Teammachine SLR (flat steerer fork)
ICS 2.0 standard integrated cables	✓
ICS 1.0 standard integrated cables	✓
1”1/8 stems external cables	⊖

First generation ICS stems “ICS1.0” is also compatible with Teammachine SLR. However, you will need to replace the top cone and spacers to ICS1.0 versions.

## Computer Mount



### Article number:

30000718 COM ICS1 ICS2 Computer Mount | ICS, ICS2, ICS MTT and RSM01 Stems

## ICS 2 Stem



### Article number:

30001784 ST ICS2 80mm  
 30001785 ST ICS2 90mm  
 30001786 ST ICS2 100mm  
 30001787 ST ICS2 110mm

## RSM01 Stem

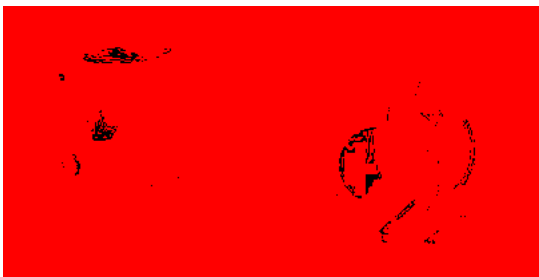

### Article number:

30007807 ST RSM01, 70 mm  
 30007808 ST RSM01, 80 mm  
 30002072 ST RSM01, 90mm  
 30002073 ST RSM01, 100mm  
 30002074 ST RSM01, 110mm  
 30002075 ST RSM01, 120mm

**Cockpit ICS Carbon**

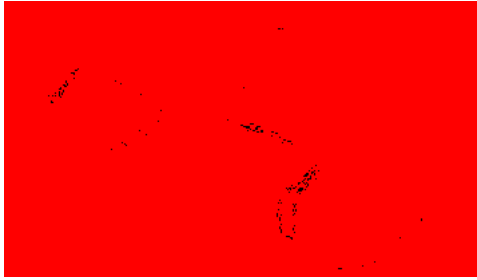

**Article number:**

- 30001767 CKP ICS Carbon 90 400 BLACK
- 30001768 CKP ICS Carbon 100 420 BLACK
- 30001769 CKP ICS Carbon 110 420 BLACK
- 30001770 CKP ICS Carbon 120 420 BLACK

30003196 Computer Mount | ICS Carbon and ICS Carbon EVO Cockpits

**Cockpit ICS Carbon Aero**



**Article number:**

- 30003720 CKP ICS2 CBN AERO 80 360/420 BLACK
- 30003721 CKP ICS2 CBN AERO 90 360/420 BLACK
- 30003722 CKP ICS2 CBN AERO 100 360/420 BLACK
- 30003723 CKP ICS2 CBN AERO 110 360/420 BLACK
- 30003724 CKP ICS2 CBN AERO 120 360/420 BLACK
- 30003725 CKP ICS2 CBN AERO 130 360/420 BLACK
- 30003726 CKP ICS2 CBN AERO 140 360/420 BLACK

30003730 Computer Mount | ICS Carbon Aero Cockpit

**Cockpit ICS2 Carbon EVO**



**Article number:**

- 30005534 CKP ICS2 CBN EVO 70 400/436 BLK
- 30005535 CKP ICS2 CBN EVO 80 400/436 BLK
- 30005536 CKP ICS2 CBN EVO 90 400/436 BLK
- 30005537 CKP ICS2 CBN EVO 100 400/436 BLK
- 30005538 CKP ICS2 CBN EVO 110 400/436 BLK
- 30005539 CKP ICS2 CBN EVO 120 400/436 BLK

30003196 Computer Mount | ICS Carbon and ICS Carbon EVO Cockpits

## Seatpost

### Seatpost Options

The Teammachine SLR is delivered with a “15mm offset” seatpost providing an ideal range of adjustment for road bike fitting.

Seatpost length is sized according to the frame size:

- 330mm on size 47, 51
- 380mm on size 54, 56, 58, 61

An optional “0mm offset” and “30mm offset” seatposts are available for riders who need a more forward or rearward position or to help deal with some particular saddle rails (carbon saddle rails can push the seating area backwards).

Replacement seatposts are available in longer versions. You may have to cut this version depending on your frame size and saddle height.

Please follow the recommended assembly instructions available in this manual “Seatpost Assembly”, page 30.



0mm offset seatpost  
(optional)



15mm offset seatpost  
(standard)



30mm offset seatpost  
(optional)

**Article number:**

30000742 SP SLR01 15mm offset



**Article number:**

30000741 SP SLR01 0mm offset



**Article number:**

30000743 SP SLR01 30mm offset



MEMBER

---

## General Notes About Assembly

### Tools

Bike specific tools are required to perform the assembly of your Teammachine SLR and its components. We recommend that you have a qualified bicycle mechanic correctly install these components.

Before you start assembling, make sure you are equipped with the following tools:

Hex keys:

- 2.5, 3, 4, 5, 6 mm

Torque wrench and bits

- Hex 2.5, 3, 4, 5, 6 mm
- Torx T10, T25

Special tools

- Carbon saw blade Park Tool CSB-1.
- Park Tool IR-1.2 Internal Cable Routing Kit

Grease compounds:

- Grease gun or grease brush
- Fine assembly grease
- Friction paste
- LOCTITE® 243 Blue threadlocker

Operator protection:

- Eye protection
- Hand protection

---

## Repair Stand

 **WARNING:** Clamping the frame or its components into a bike repair stand could damage its structure or finish.

 **WARNING:** Never clamp the frame by the top tube, downtube or seat tube.

Please use a traditional fork mount stand like the Park Tool PRS-22.2 Team Issue Repair Stand.

MEMBER

# Torque Specifications

**⚠ WARNING:** Respecting and applying the correct torque on fasteners is important for your safety. If too little force is applied the component will not be secure and if too much force is applied the component's thread could deform and break.

Therefore, not respecting the torque specification of any component could result in failure, which can cause loss of control and a fall.

## Teammachine SLR Torque Specifications

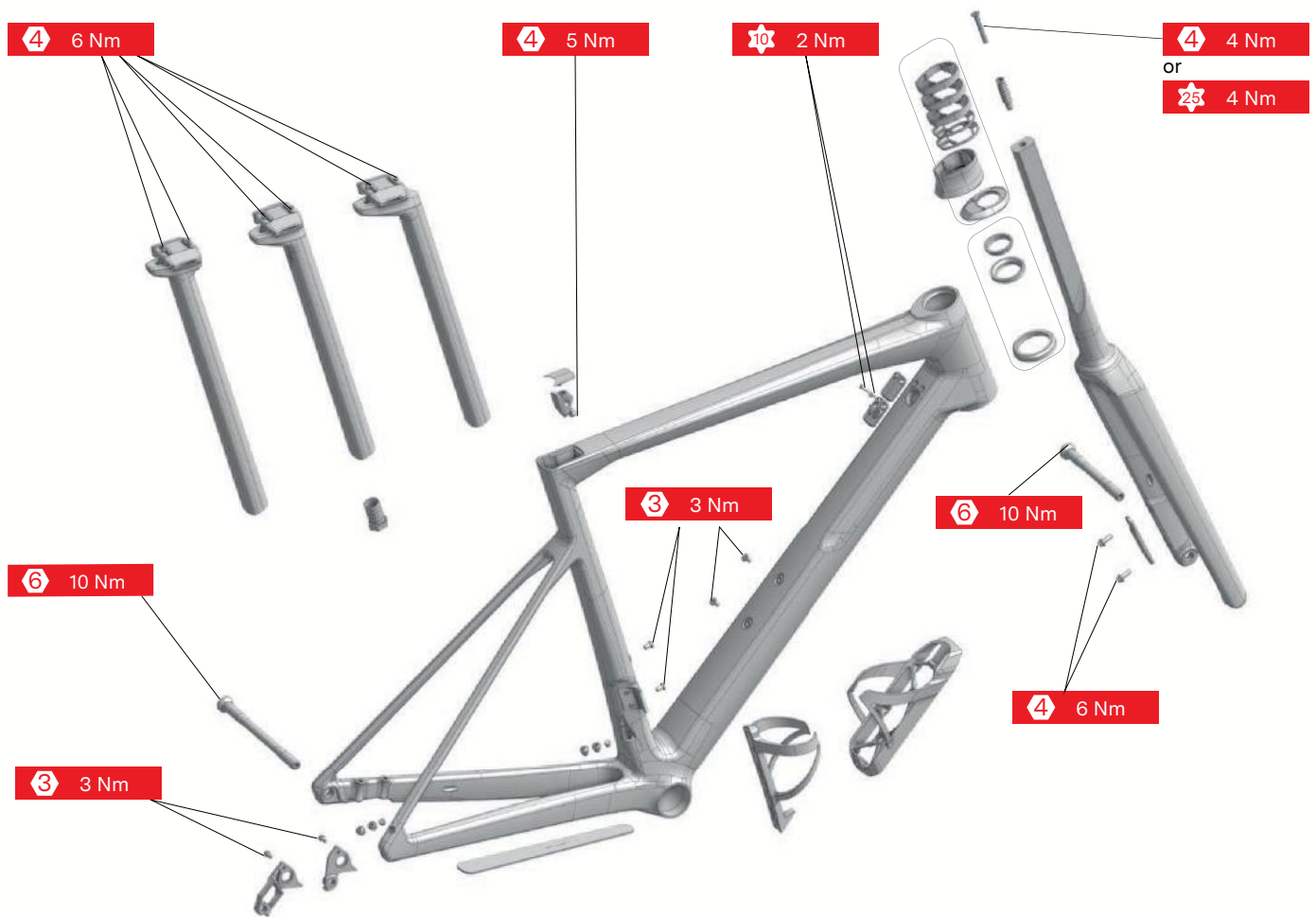

MEMBER

## Recommended Assembly Procedure

If you are building a Teammachine SLR from scratch, the most convenient way is to follow the order and the procedure described below. This is only the general procedure, all the separate steps and recommendations are described one by one in the following pages of this manual.

**i** INFORMATION: Please go through all the instructions before starting. Following this sequence will help you save time and facilitate the assembly.

- Sizing and parts selection
- Frame preparation
- Cockpit preparation
- Fork preparation
- Seatpost preparation
- Electronic wires installation
- Seatpost assembly
- Brake caliper assembly
- Headset and fork assembly
- Cockpit assembly
- Bottom bracket and crankset assembly
- Bottle cages
- Wheels and axles

# Sizing and Parts Selection

## Positioning

A bicycle rider will only perform at their best if they are correctly positioned on their bike. Proper positioning not only enhances your riding experience but also helps prevent strain or injury over time.

To ensure optimal comfort, performance, and safety while riding, we strongly recommend utilizing a professional bike fitting service when ordering or setting up your new bike. A bike fitter can assess your unique body requirements, riding style, and flexibility to fine-tune your bike's adjustments, such as saddle height, saddle position and handlebar position.

If a professional bike fitting is not immediately accessible, take the time to carefully evaluate your bike's setup to ensure it matches your riding needs and personal measurements. If you are transitioning from a previous bike, it is crucial to confirm that your current bike setup is appropriate for your new bike's geometry and specifications.

## Frame Size

### General Frame Geometry

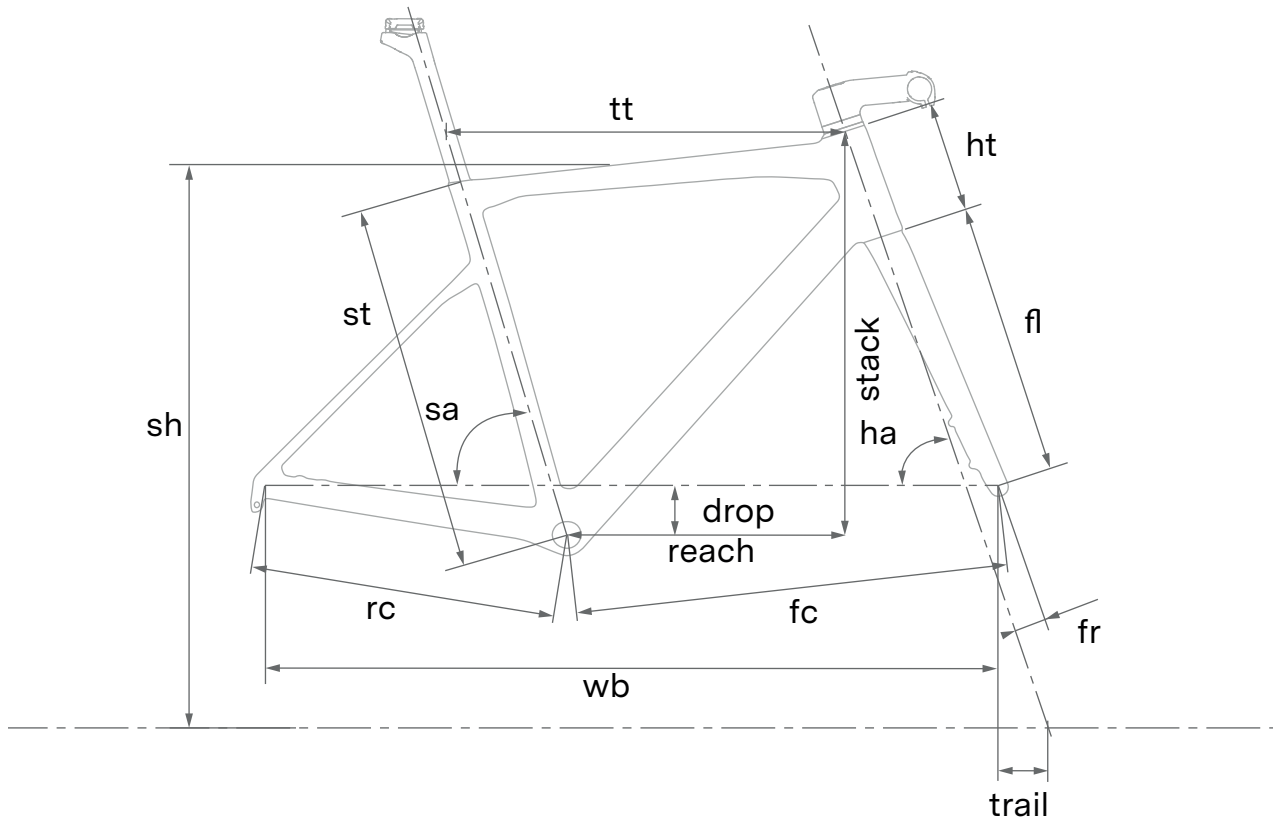

Size	47	51	54	56	58	61
Rider Height cm	< 160	158-174	172-180	178-186	184-192	> 190
Stack	525	550	570	595	620	645
Reach	370	379	383	388	393	398
Seat Tube (st)	414	461	488	508	529	550
Top Tube (tt')	520	537	546	559	571	581
Head Tube (ht)	112	138	154	181	207	233
Seat Angle ° (sa)	74.2	74.2	74.2	74.2	74.2	74.2
Head Angle ° (ha)	71.4	71.4	72.2	72.2	72.2	72.2
Rear Center (rc)	415	415	415	415	415	415
Front Center (fc)	579	596	594	607	620	633
Wheelbase (wb)	982	1000	997	1010	1023	1036
BB drop (drop)	75	75	75	75	75	75
Fork Length (fl)	379	379	379	379	379	379
Fork Rake (fr)	50	50	45	45	45	45
Trail	63	63	63	63	63	63
Standover Height (sh)	726	762	786	807	828	849

MEMBER

# Detailed Assembly Instructions

## Frame Preparation

### Rear Derailleur Hanger Installation

- Select the right model of hanger depending on your groupset, and the rear derailleur design. You can choose between the standard dropout hanger or the direct mount dropout hanger. The Direct Mount hanger is usually specified for Shimano's latest generation of derailleurs.

Standard



Direct mount



- Position the selected dropout hanger on the frame dropout and bolt on the M4x8 bolt using a hex 3mm.
- Tighten to 2 Nm.

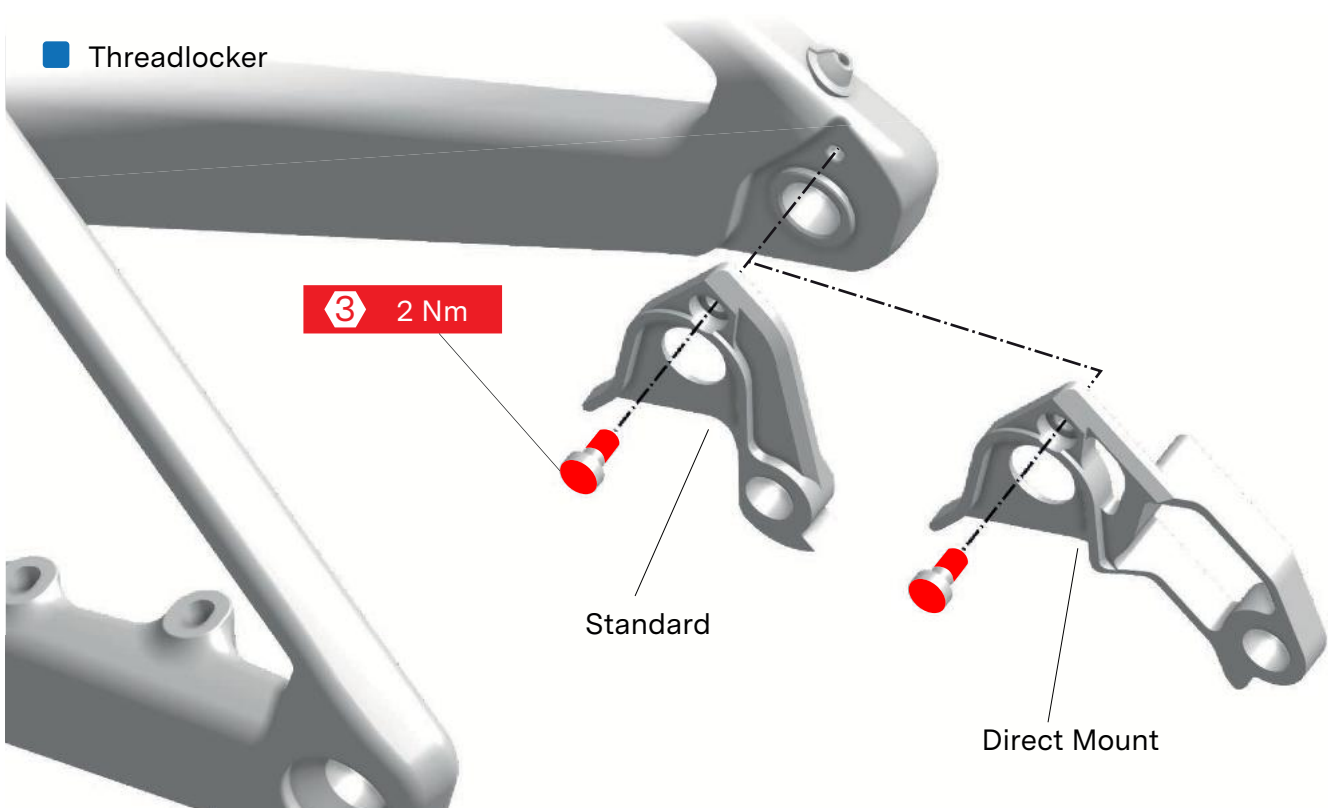

- Select the right model of rubber grommet or plug depending on your groupset and push it into the frame opening.

■ Push in the appropriate plug or grommet

Sram AXS



Shimano Di2



Mechanical shifting



## Front Derailleur Plug Installation

**i** INFORMATION: Our Teammachine SLR frames are designed to accommodate round chainrings of maximum 55 teeth and minimum 31 teeth.

**i** INFORMATION: Our Teammachine SLR frames are designed for road chainline of 44.5-45.0mm..

**⚠** WARNING: Chainrings not listed above can not be guaranteed compatible with our frame design. An assembly check is necessary to confirm a 4mm minimum clearance between the chainring, chain and frame.

**⚠** WARNING: Our Teammachine SLR are not compatible with SRAM 2x Wide transmissions. Please select one of the standard road transmissions.

- Select the right model of rubber grommet or plug depending on your groupset and push it into the frame opening.

- Push in the appropriate plug or grommet

Sram AXS

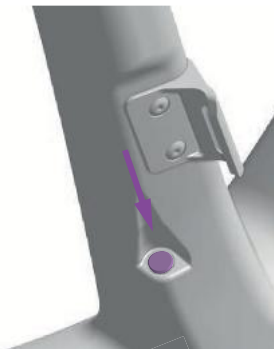

Shimano Di2

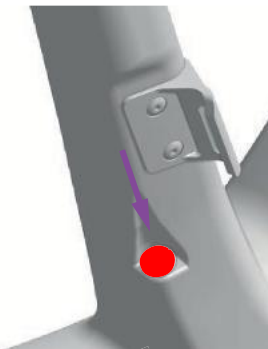

Mechanical shifting

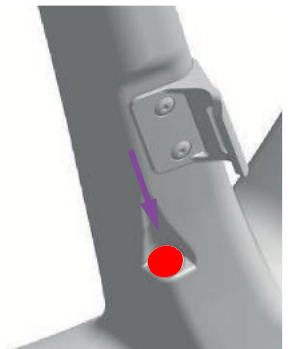

## Electronic Wires Installation

### Shimano Di2

**⚠ WARNING:** Please always refer to the latest Shimano product information for your groupset. The following information is a guide with basic principles.

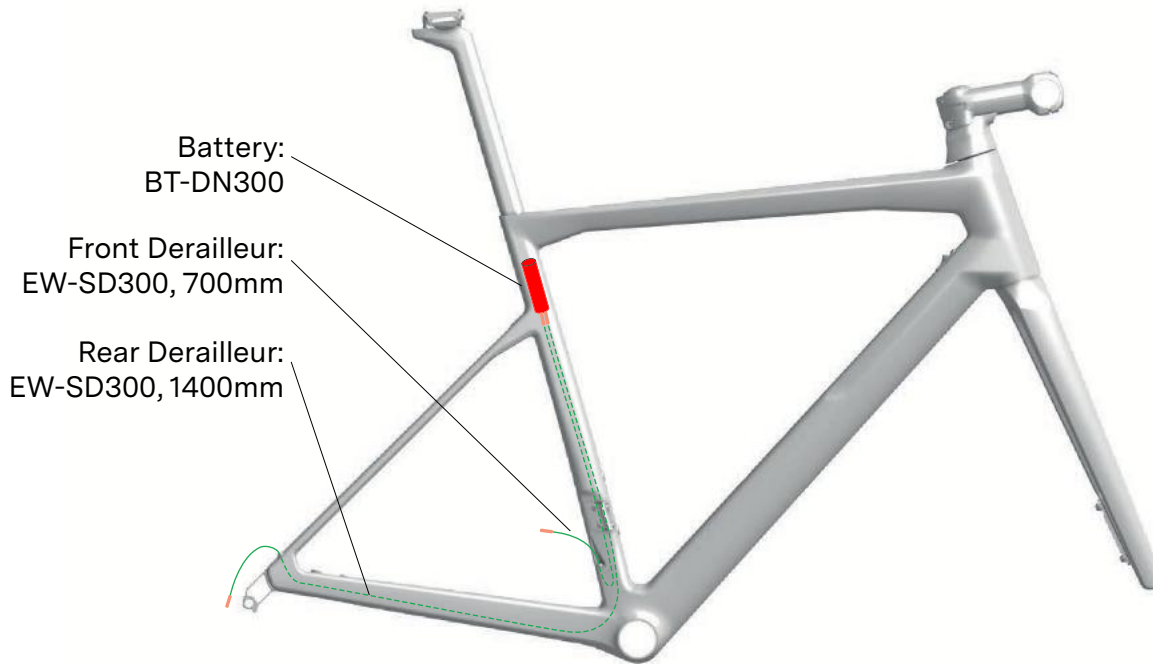

Recommended wire lengths:

Location	Part code	Length
Front Derailleur	EW-SD300	700mm
Rear Derailleur	EW-SD300	1 400mm

• Install the different electronic wires into the frame.

**i INFORMATION:** It helps a lot to use a cable routing guiding tool like the Park Tool IR-1.2 Internal Cable Routing Kit

- Install the Shimano battery adapter on the Shimano Di2 battery.



- Enlarge the adaptor and slide onto the battery

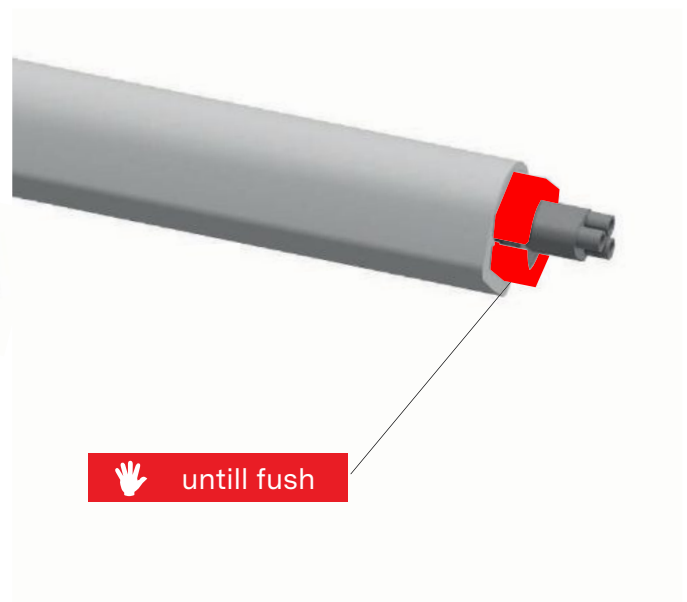
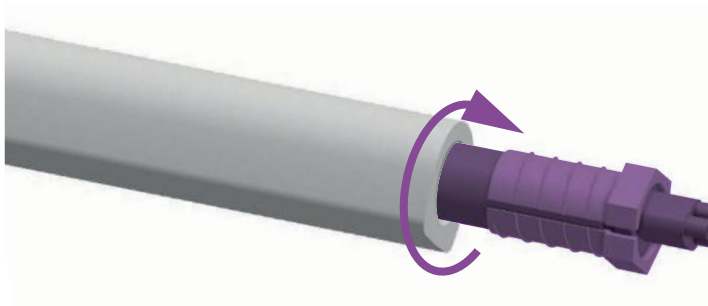

- Screw the adaptor into the seatpost foam core

- Screw in the seatpost internal foam core using a 21mm flat wrench. Tighten lightly until the adapter head is flush to the seat post foam core.

# Seatpost Assembly

## Seatpost Length

The three seatposts compatible with the Teammachine SLR have a minimum and a maximum insertion depth in the frame.

Size	47	51	54	56	58	61
Seatpost Length	330	330	380	380	380	380
Min insertion	80	80	80	80	80	80
Max insertion	130	170	200	220	235	250

**⚠ WARNING:** Always make sure you are respecting the min insertion length of 80mm.

**ℹ INFORMATION:** If the max insertion is too restricting and does not allow a low enough saddle height, you can cut your seatpost to a shorter length to allow you to reach your ideal saddle height.

**ℹ INFORMATION:** Use a saw guide like the Park Tool SG-7.2 Oversized Adjustable Saw Guide and an appropriate carbon specific saw blade such as the Park Tool CSB-1.

**⚠ WARNING:** If cutting the seatpost, make sure to respect the maximum cutting instruction.

**⚠ WARNING:** Minimum seatpost length is limited to 240mm using a D12 battery. This length is not guaranteed and varies depending on manufacturing batch and seatpost type. Please cut the seatpost progressively to ensure proper installation of the battery.

■ Maximum cutting length

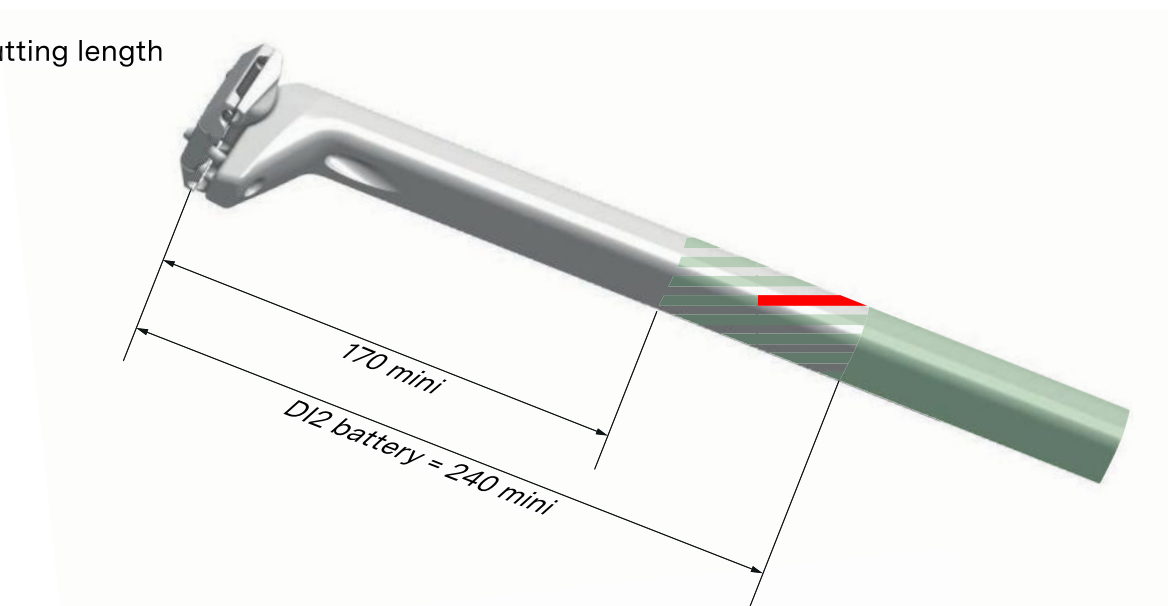

## Saddle Clamp Installation

- Pre-install the lower clamp, the upper clamp, the barrel nuts and finally pre-install the 2 M6 bolts with their washer:
  - Long M6x35 at the front.
  - Short M6x30 at the rear.
- Install your saddle by clamping the rails between the 2 clamps and adjust the saddle setback and tilt before clamping both the M6 bolts.
- Tighten to 6 Nm using a hex 4mm.

**⚠ WARNING:** Always tighten to the correct torque. Not respecting this recommendation may result in the saddle coming loose, losing control of the bike and falling.

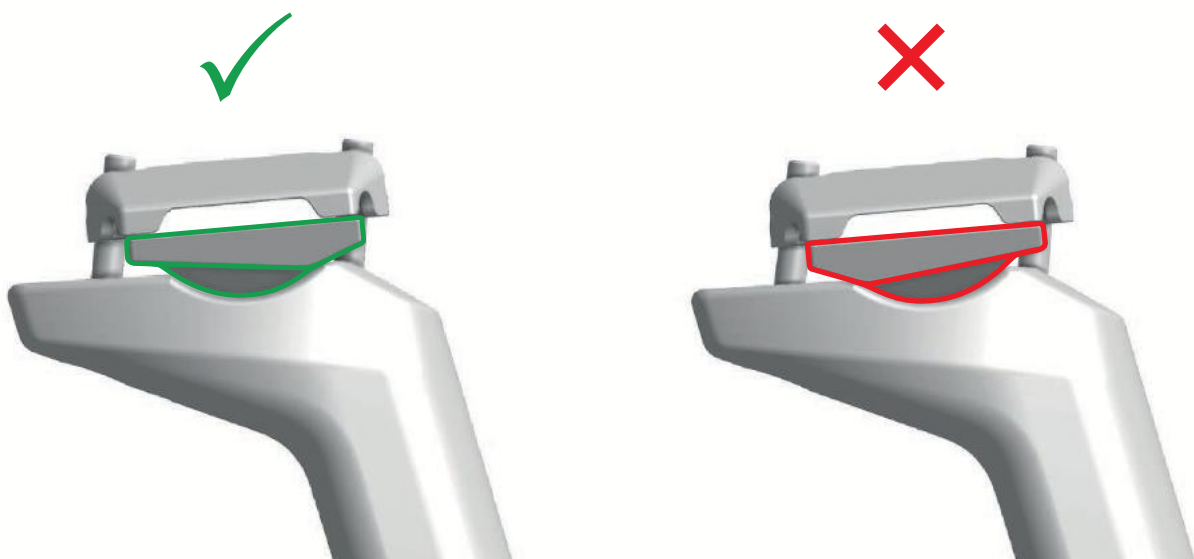
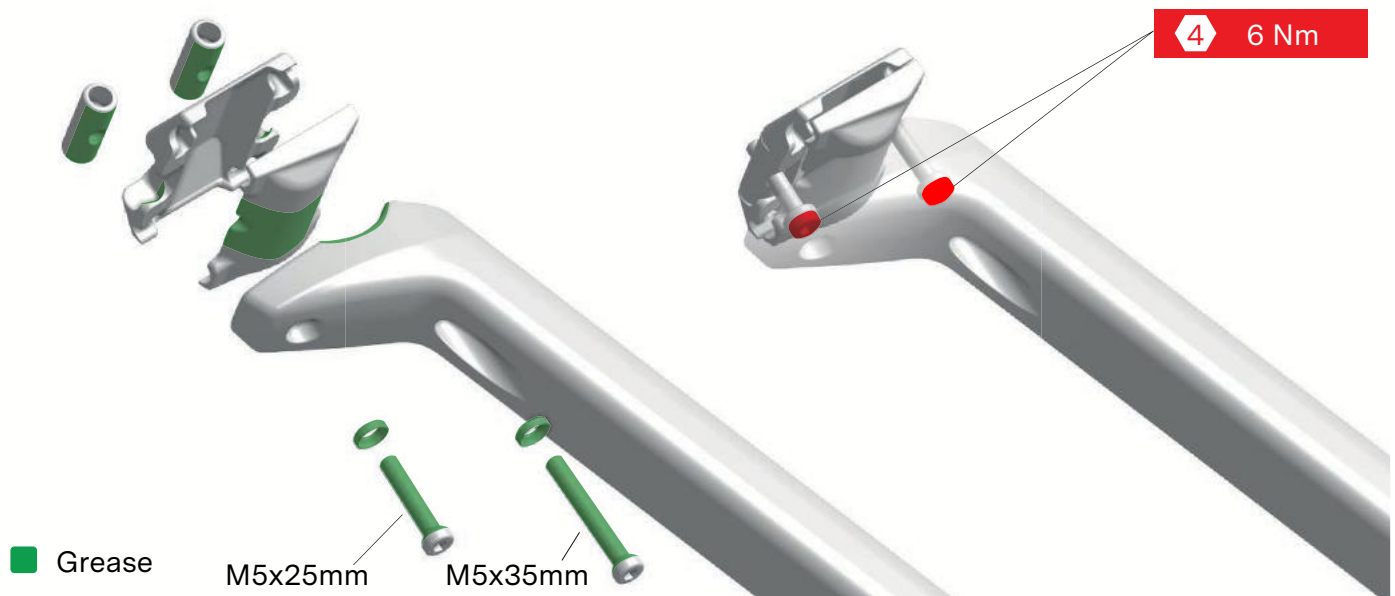

**⚠ WARNING:** Always respect the orientation of the lower clamp as illustrated above.

## Frame Seatpost Clamp Installation

- Install the seat post rubber seal onto the seat post.
- Apply a thin layer of friction paste onto the back and the side surfaces of the seatpost and inside the seat tube.
- Grease the M5x32, the barrel nut and the back side of the wedge.
- Install them into the frame cavity without tightening.
- Slide the seatpost in and adjust it at your desired saddle height.

**⚠ WARNING:** Remember to respect the minimum insertion of 80mm. Not respecting the minimum insertion could result in frame or seatpost damage, breakage and injury.

**ℹ INFORMATION:** Our spare part “Seatpost Clamp No. 26” (30000702) is including 2 different covers. Please refer to the inscription to select the right size depending on your frame size.

47&51: for sizes 47 and 51

45-61: for sizes 54, 56, 58 and 61.

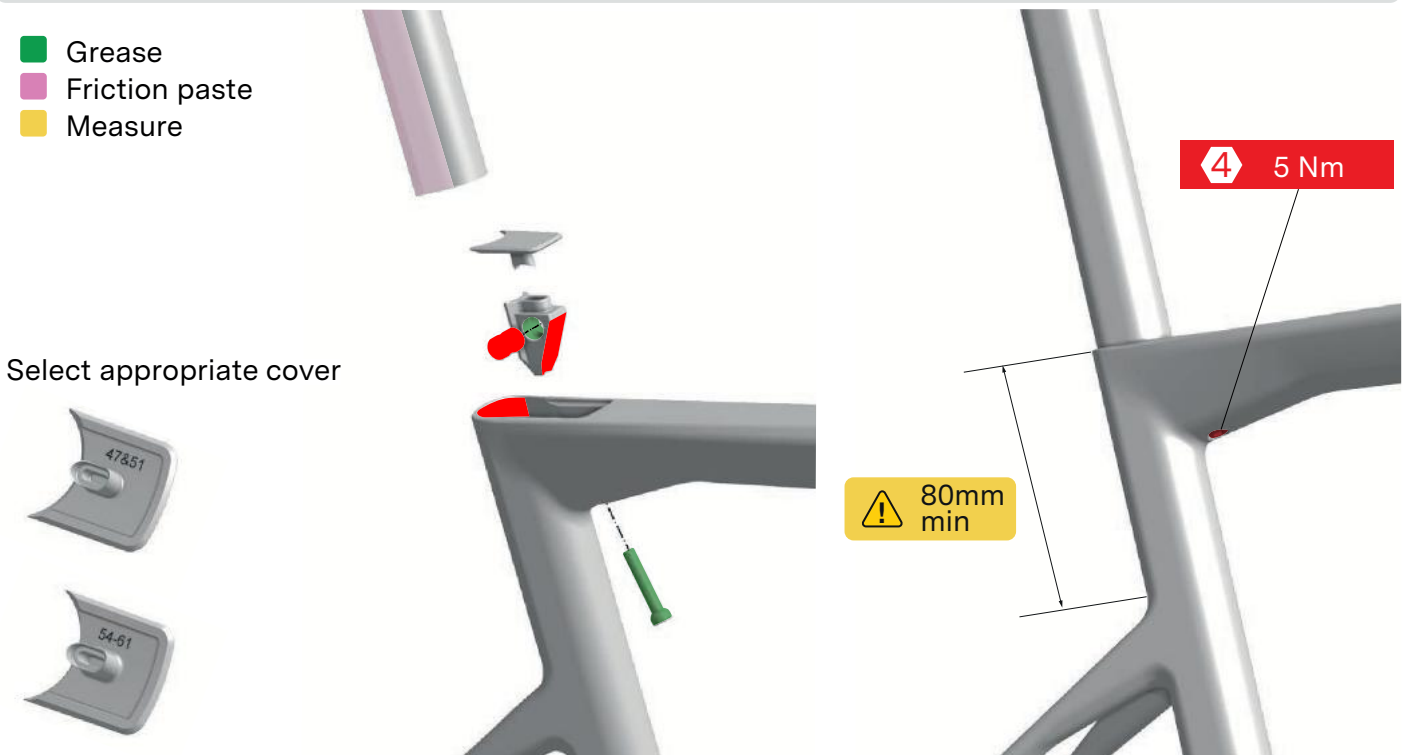

- Tighten the M5x32 bolt to 5 Nm using a hex 4mm wrench.

## Fork, Headset and Cockpit Preparation

### Cockpits and Stems Parts Selection

• Refer to the following illustrations to identify each component.

#### ICS Cockpit

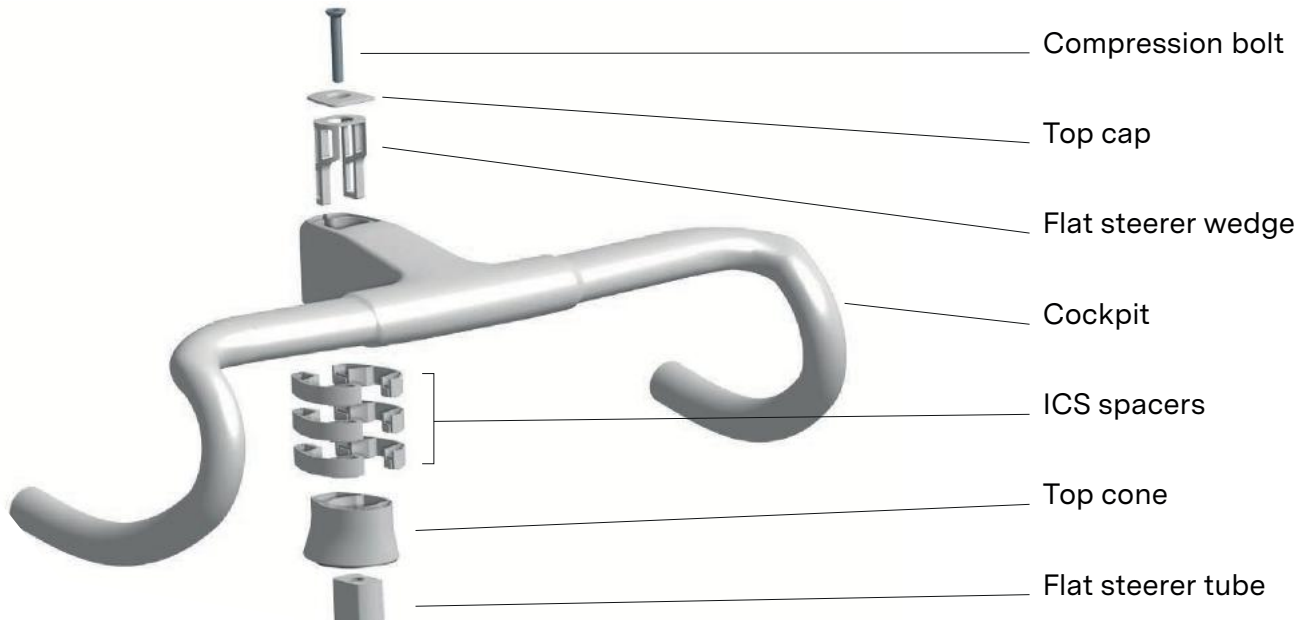

#### ICS Stem

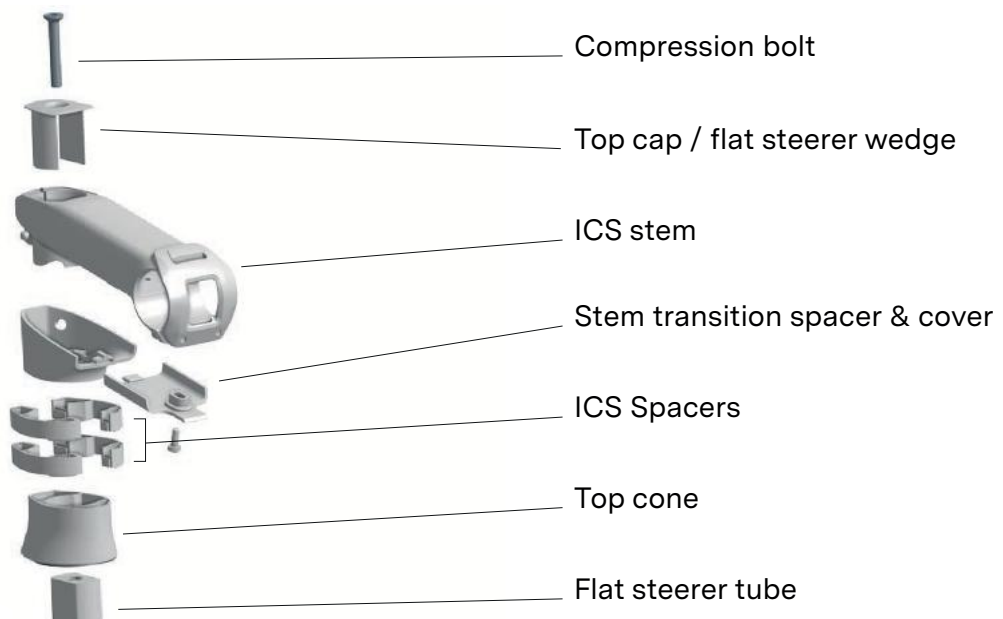

**RSM01 with ICS Core**

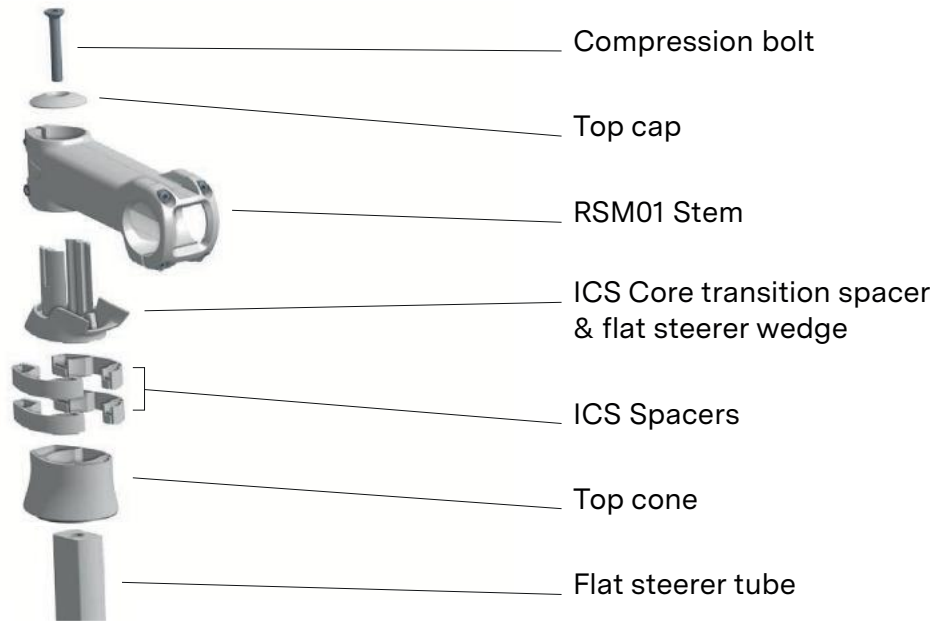

## Minimum and Maximum Spacer Stack

- Determine the stack height based on the rider’s initial or desired position.

**⚠ WARNING:** do not exceed the spacer height and spacer count. Failure to follow these recommendations may result in steering issues resulting in losing control of the bike and a potential crash.

	ICS Carbon cockpits		ICS Stems		RSM01 stem and ICS Core	
<b>Top cone</b>	#1 Low [or] #2 High		#1 Low [or] #2 High		#1 Low [or] #2 High	
<b>Spacer type</b>	ICS		ICS		ICS	
<b>Spacer max quantity</b>	3		2		2	
<b>Stack options</b>	Lowest	Highest	Lowest	Highest	Lowest	Highest
<b>Stack height</b>	5mm	60mm	15mm	60mm	15mm	60mm
<b>Stem cover</b>			10	10	10	10
<b>Spacers</b>		3x 10		2x 10		2x 10
<b>Top cone</b>	#1 Low (5mm)	#2 High (30mm)	#1 Low (5mm)	#2 High (30mm)	#1 Low (5mm)	#2 High (30mm)



## Definition of Steerer Tube Length

**⚠ WARNING:** The steerer tube should be cut to the correct length for optimal mechanical function and aesthetics.

- Install the headset components to determine the cutting length of the steerer tube:
  - Fork
  - Lower bearing
  - Upper bearing
  - Compression ring
  - Top cone (high or low)
  - Spacers
  - Stem cover and stem body [or] cockpit
- Clip the right and left sides of each spacer by sliding them into place on top of one another..

### ■ Align and clip

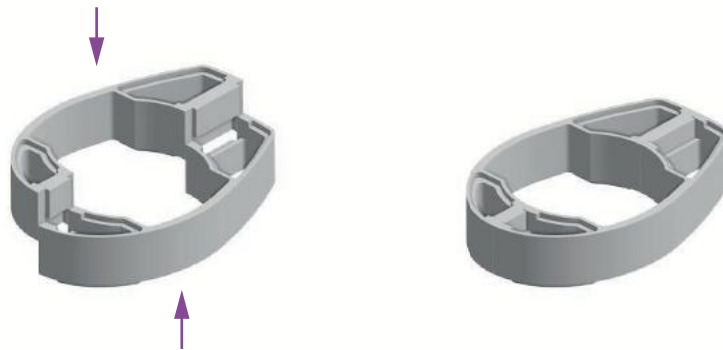

- Align the different elements to achieve the desired stack.

### ■ Pre-assemble all components



- Gently compress the system together and tighten lightly the cockpit or stem to the steerer tube.

**i INFORMATION:** Grease is not necessary at this stage.

**⚠ WARNING:** Do not tighten the stem's steerer clamping bolts without the ICS wedges in place. Tightening the stem's steerer clamping bolts without the wedges can compromise the integrity of the steerer tube, potentially leading to failure and serious injury.

- Control the handlebar stack and reach to make sure the setup is matching the original bike fit coordinates.
- Using a silver or white marker pen, make a mark on the steerer tube at the top of the stem.

■ Mark the steerer at top of stem

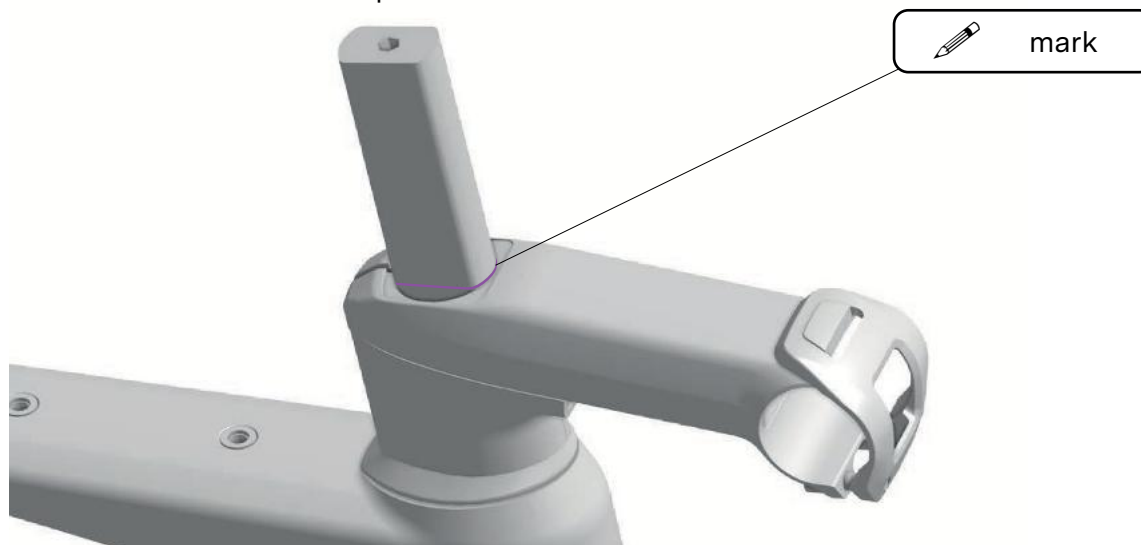

- Uninstall the fork and headset from the frame.

## Steerer Tube Length and Cutting

**⚠ WARNING:** While it is possible to ride with a steerer tube extending above the stem, we strongly recommend cutting it to the appropriate length. This minimizes the risk of injury while riding or in the event of a fall.

**⚠ WARNING:** The steerer tube must be cut 3mm below the top cap contact surface to allow for proper headset compression and preloading.

- From the previously marked line, measure and mark a new cutting line 3mm lower.
- Use a carbon saw blade to cut the steerer tube.

■ Report cutting length

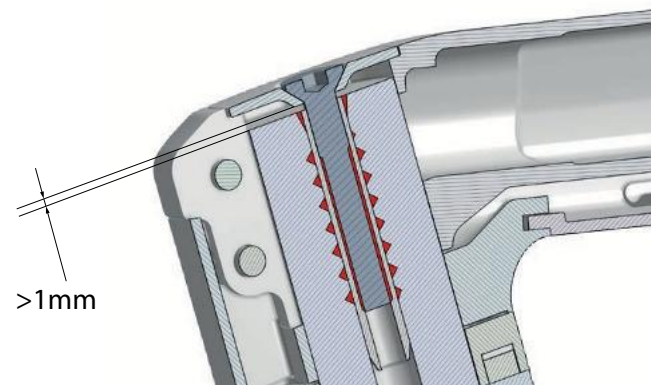
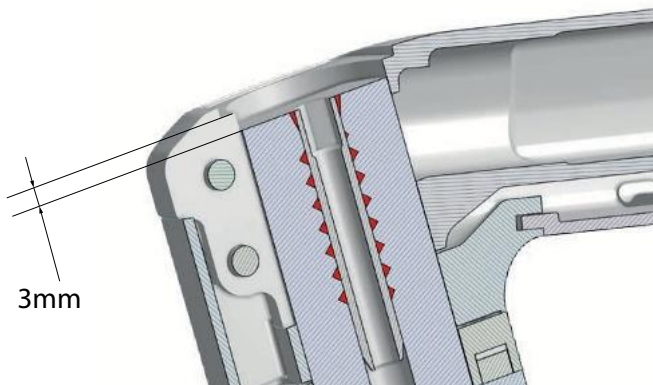
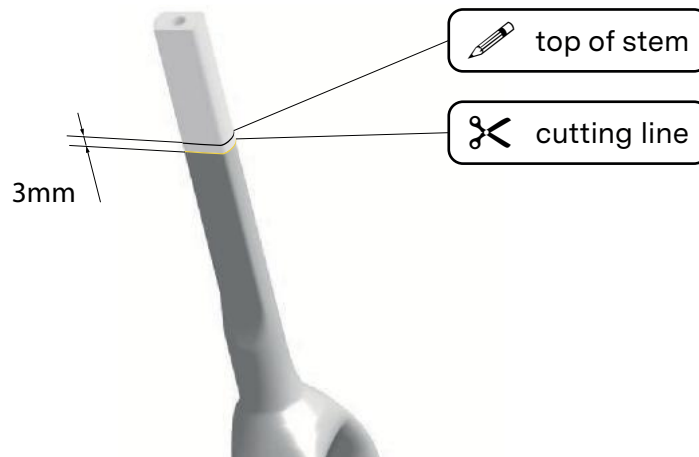

**i INFORMATION:** Applying tape underneath the cutting line will help guide the saw blade and reduce the risk of carbon delamination.

**i INFORMATION:** Use a saw guide and an appropriate carbon-specific saw blade, such as the Park Tool CSB-1.

## Expander Installation

- Grease the self-cutting expander bolt to facilitate installation.
- Push the expander into the flat steerer foam and turn it clockwise while applying downward pressure.
- Tighten until the expander bolt head is flush with the top of the steerer.

■ Grease

■ Screw in the self-cutting expander until it's flush

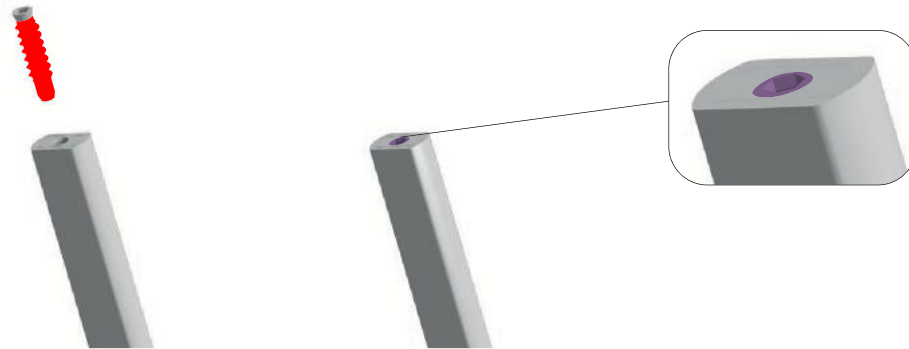

## Brake Calipers Assembly

### Rear Brake

The rear brake must be installed either:

- Directly on the frame brake mount for 140mm rotor compatibility
- Using a 20mm bracket for 160mm rotor compatibility.
- Select the rear brake adapter and bolts. Refer to brake caliper's manufacturer to determine:
  - The correct adapter plate based on your rotor size.
  - The correct bolt length for frame mount of 25mm thickness.
  - The appropriate torque value.

**⚠ WARNING:** Always use the rear brake bracket specified by the brake caliper manufacturer.

■ Use for 160mm rotor

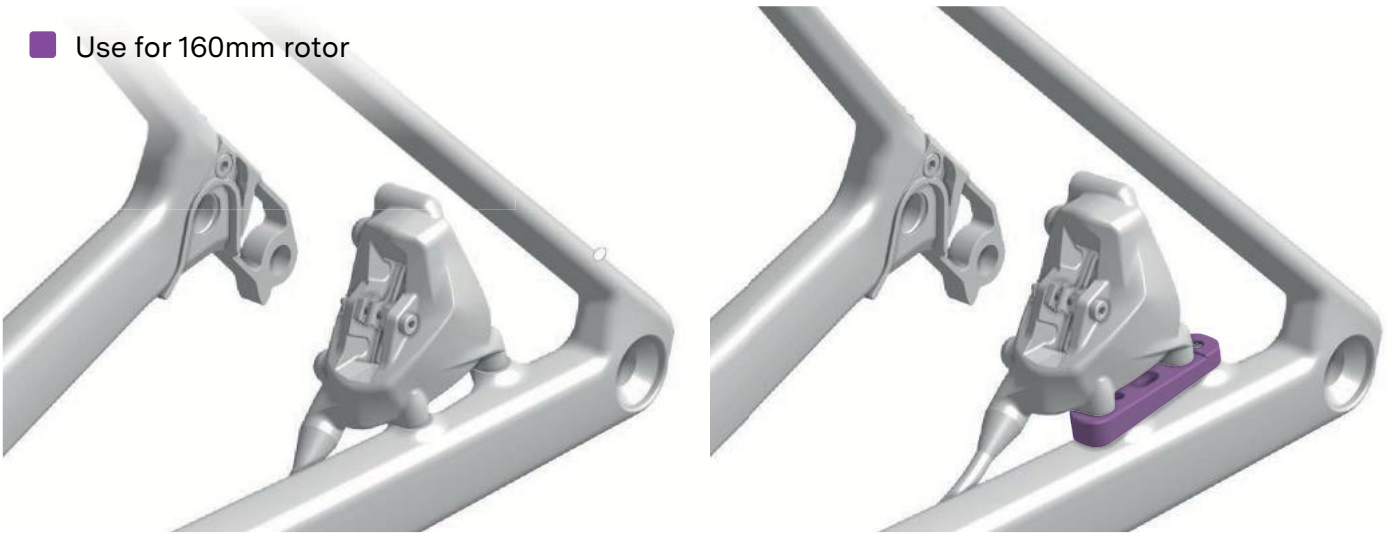

- Push the rear brake hose from the back to the front inserting it in the left chainstay opening.
- Guide the hose through the downtube and let the hose exit at the front of the bike.
- To avoid noise and rattling, install a foam tube over the brake hose and push it so it fits within the middle of the downtube.

■ Route through chainstay and downtube



- Bolt on the rear caliper on the flat mount brake mount using appropriate bolts and follow brake manufacturer's recommendation for installation (threadlocker and torque)

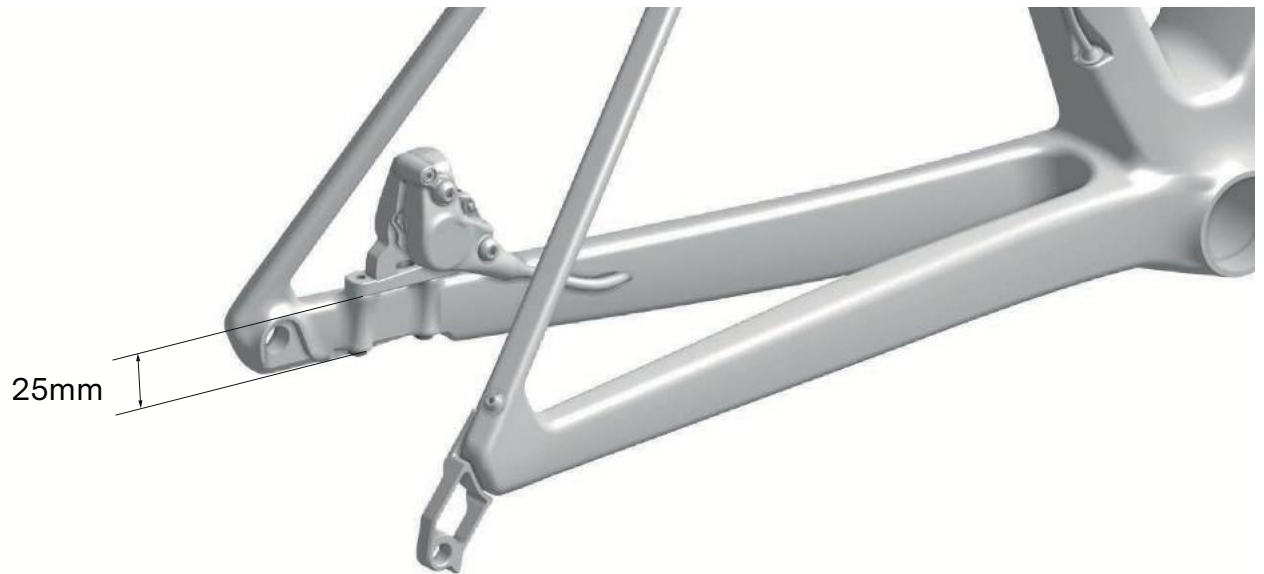

## Front brake

The front brake must be installed directly onto the specific BMC front bracket adapter. The Teammachine SLR is designed exclusively for a 160mm front rotor.

**⚠ WARNING:** There are multiple front brake adapter plate designs. Ensure you are using the part provided with the Teammachine SLR.



- Install the front caliper adapter plate onto the front caliper.
- Ensure the brake mount is in the correct position. The “UP” mark must face upward and outward, as shown in the illustration below.



- Torque the countersunk bolts according to the brake caliper manufacturer’s recommendations.
- Route the front brake hose through the fork.
- Install the front brake adapter to the fork mount using the two M5x14 bolts.

**⚠ WARNING:** remove old threadlocker and apply a new coat of LOCTITE® 243 Blue threadlocker.

■ Threadlocker

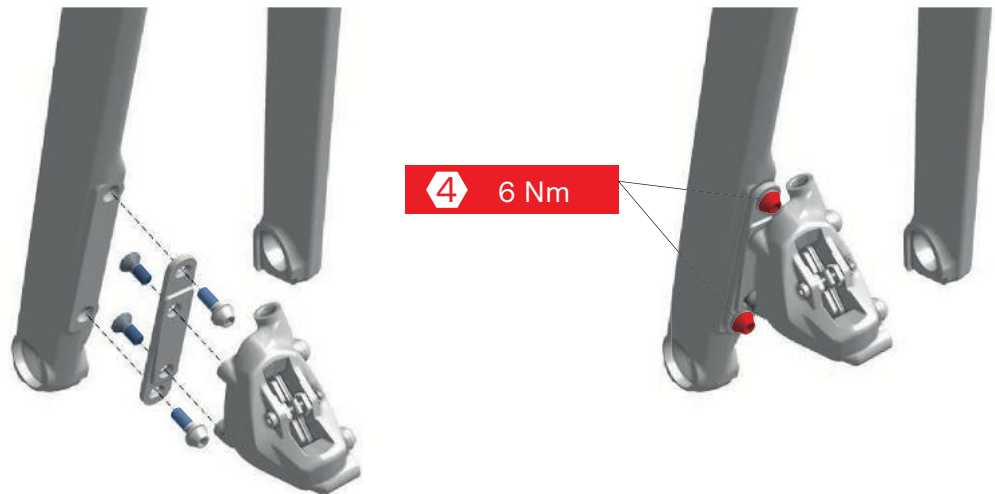

- Tighten to 6 Nm using a hex 4mm wrench.
- Route the front brake hose alongside the flat steerer. Follow the table instruction to place the hose on the appropriate side of the steerer tube.

	Standard setup front brake = left hand	UK setup front brake = right hand
<b>ICS Cockpits</b>	right drive side	left non drive side
<b>ICS Stems</b>	left non drive side	right drive side

**i** INFORMATION: Crossing brake hose (cable routing) in an ICS cockpit is preferable. It will allow an easier installation and smoother steering.

- Hold the brake hose on the flat steerer by wrapping with electrical tape.

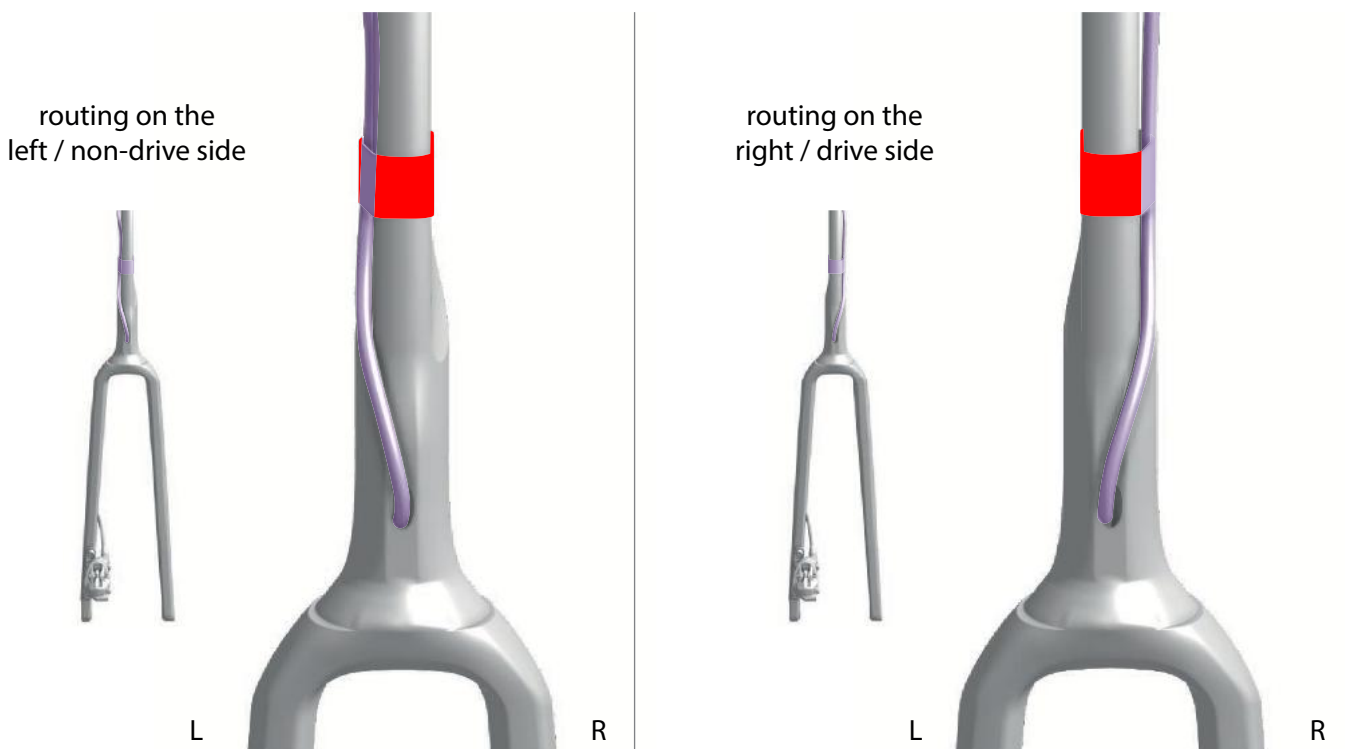

## Shifting Cables Assembly

**INFORMATION:** This paragraph covers mechanical shifting cable installation. For electronic shifting wires installation, please refer to “Electronic Wires Installation”, page 28

### Downtube Cover

- Place the appropriate cover on the downtube opening.
  - Option A: “ICS full integrated” uses a blind cover
  - Option B: “external” uses a cylindrical plug that fits in the upper hole of the down tube.

- Place the appropriate cover & bolts

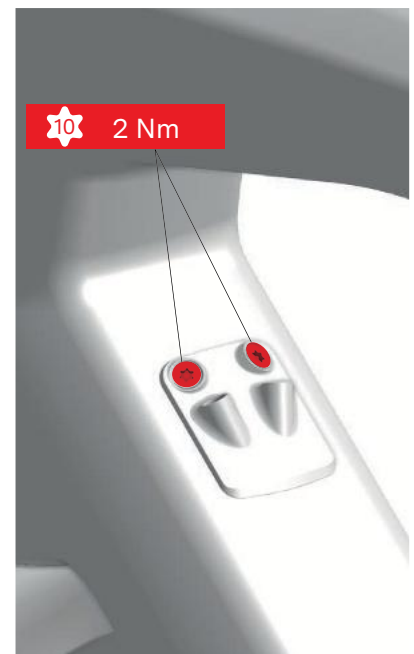
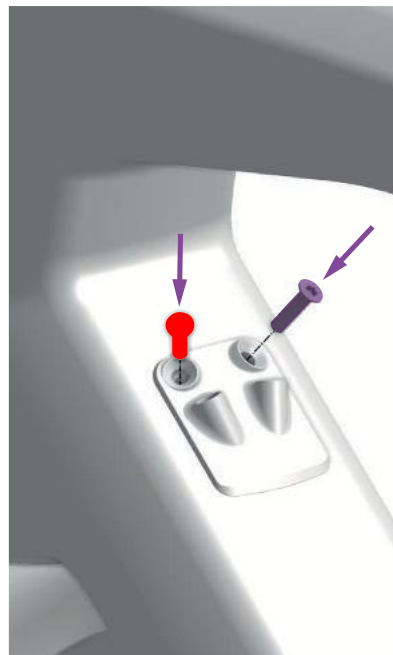
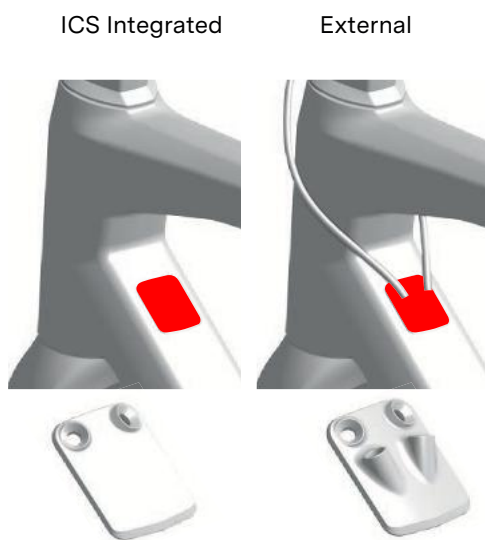

Tighten the M3x12 bolt to 2 Nm using a Torx 10 wrench.

### Internal Shifting cable

- Push the front shifting hose from the back to the front inserting it in the seat tube opening.
- Push the rear shifting hose from the back to the front inserting it in the right chainstay opening.
- Guide the hoses through the downtube let the hoses exit at the front of the bike through the head tube.
- To avoid noise and rattling, install foam tubes over each index hose and push them so they fits within the middle of the downtube.

■ Route through chainstay and downtube



## External Shifting Cable

- Push the front shifting hose from the back to the front inserting it in the seat tube opening.
- Push the rear shifting hose from the back to the front inserting it in the right chainstay opening.
- Guide the hoses through the downtube let the hoses exit at the front of the bike trough the downtube opening.
- To avoid noise and rattling, install foam tubes over each index hose and push them so they fits within the middle of the downtube.

■ Route through chainstay and downtube



# Headset, Top Cone and Spacers Assembly

## Headset Assembly

The Teammachine SLR is designed to fit a BMC by FSA, HS-B-13 bearings set.

Specifications of these bearings are:



	Reference	Dimensions
<b>Upper bearing</b>	MR155	30.5 x 41.8 x 7.5 ; 45x45°
<b>Lower bearing</b>	MR019	40.0 x 51.8 x 7.5 ; 45x36°

**ⓘ INFORMATION:** Upgrade of bearings headsets will be available soon in 2025 thanks to new quality of headset bearings.

30007614 HS B 27 Stainless headset bearings

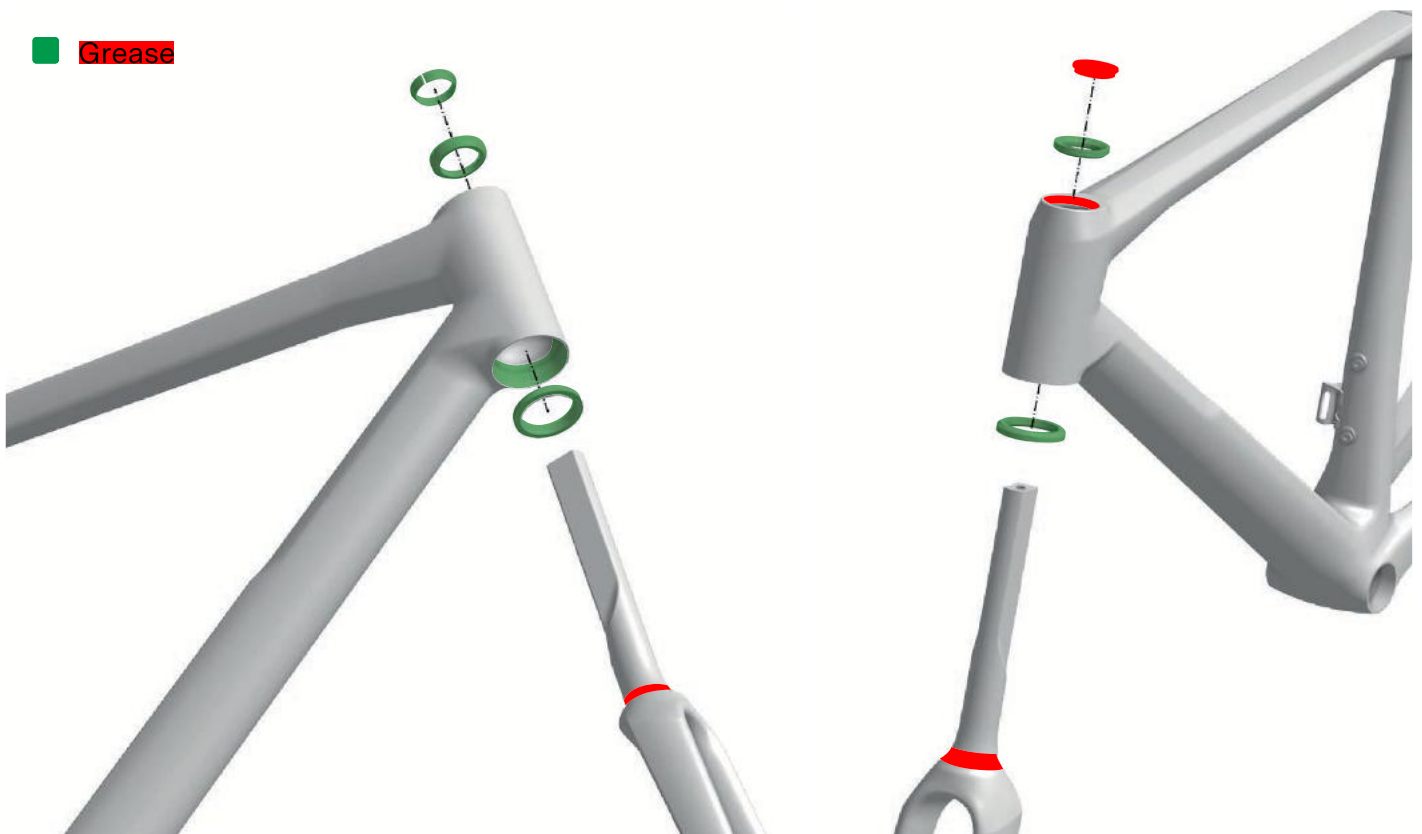

- Install the lower bearing on the fork crown, applying grease to the frame bearing race, fork crown contact surface, and bearing surfaces.
- Route the front brake hose through the head tube, then insert the fork steerer tube through the head tube and headset bearings.
- As the front and rear brake hoses exit from the top of the head tube, install the upper bearing in the frame head tube, applying grease to the frame bearing race and bearing surfaces.
- Grease the headset compression ring and slide it onto the steerer tube, ensuring its slot is oriented to either the right or left side.

**■ Compression ring orientation**





**⚠ WARNING:** Do not orient the compression ring slot toward the front or back. Doing so will negatively affect the compression of the headset.

**⚠ WARNING:** Do not apply friction paste to the steerer tube or the bearings.

## Cockpit or Stem Installation

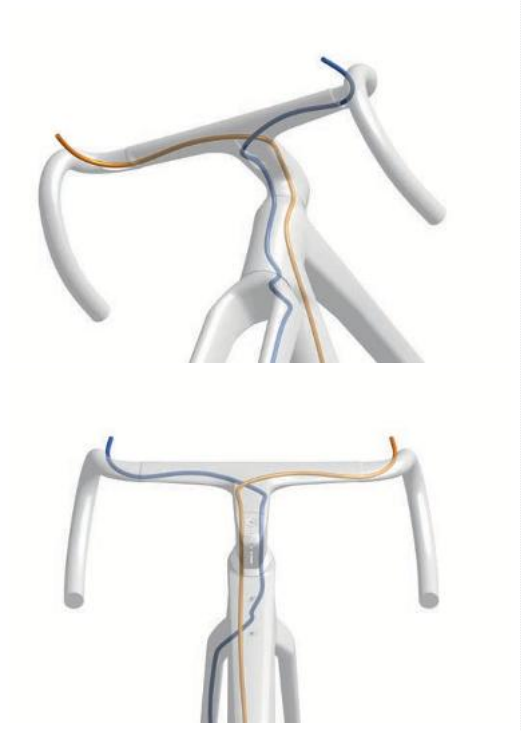
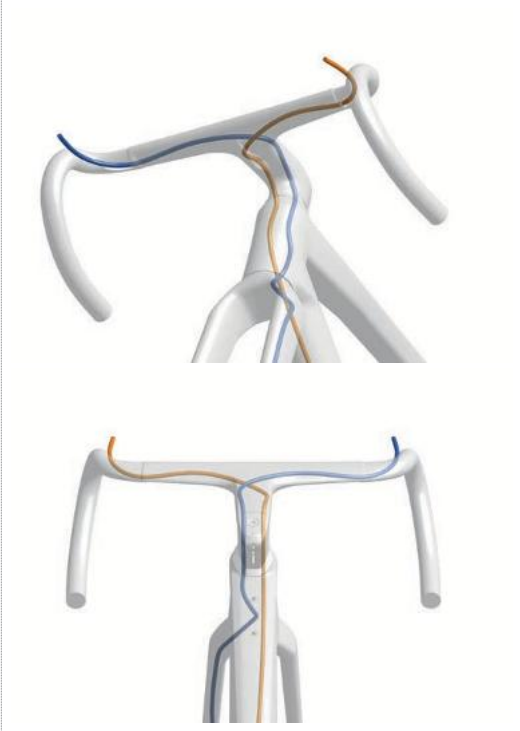
- Route front and rear brake hoses through the stem or cockpit.
- Follow the table instruction to place each hose on the correct side of the stem or cockpit guides.

	Standard setup front brake = left hand	UK setup front brake = right hand
ICS Cockpits		
ICS Stems		

- Compile the different elements of the stem/handlebar or cockpit as determined in “Fork, Headset and Cockpit Preparation” on page 33.

**⚠ WARNING:** Do not tighten the stem steerer clamping bolts without the ICS flat steerer wedges. Tightening the stem steerer clamping bolts can compromise the integrity of the steerer tube – leading to failure and serious injury.

**ICS Cockpit**

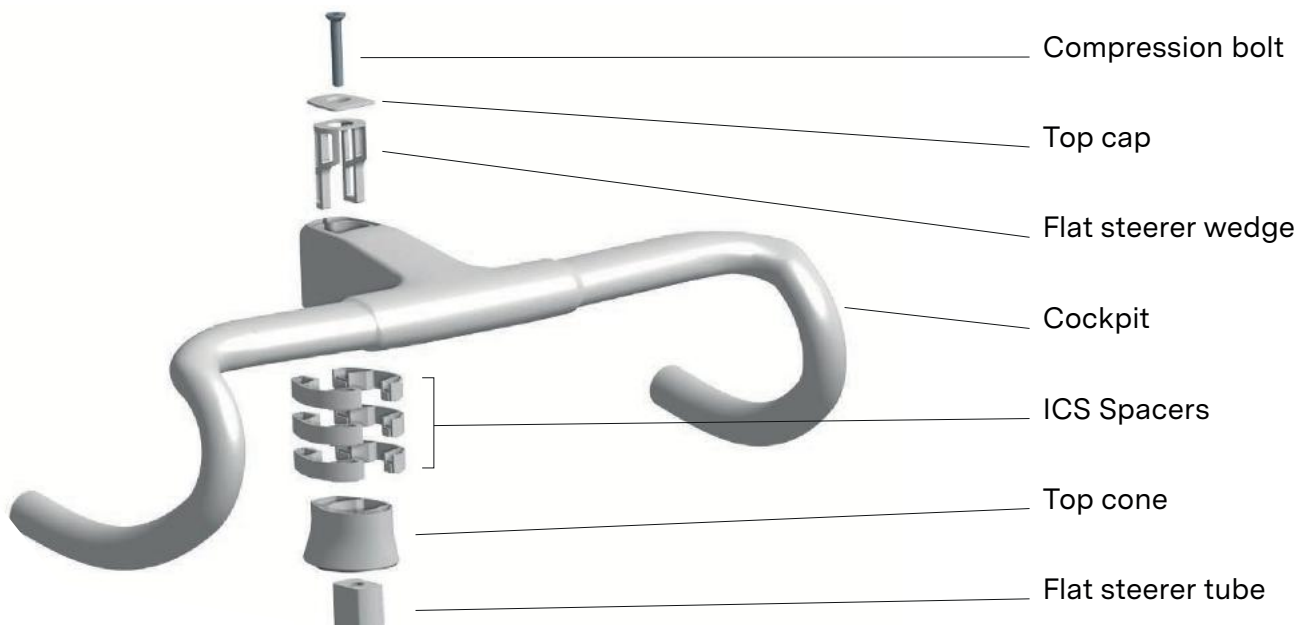

**ICS Stem**

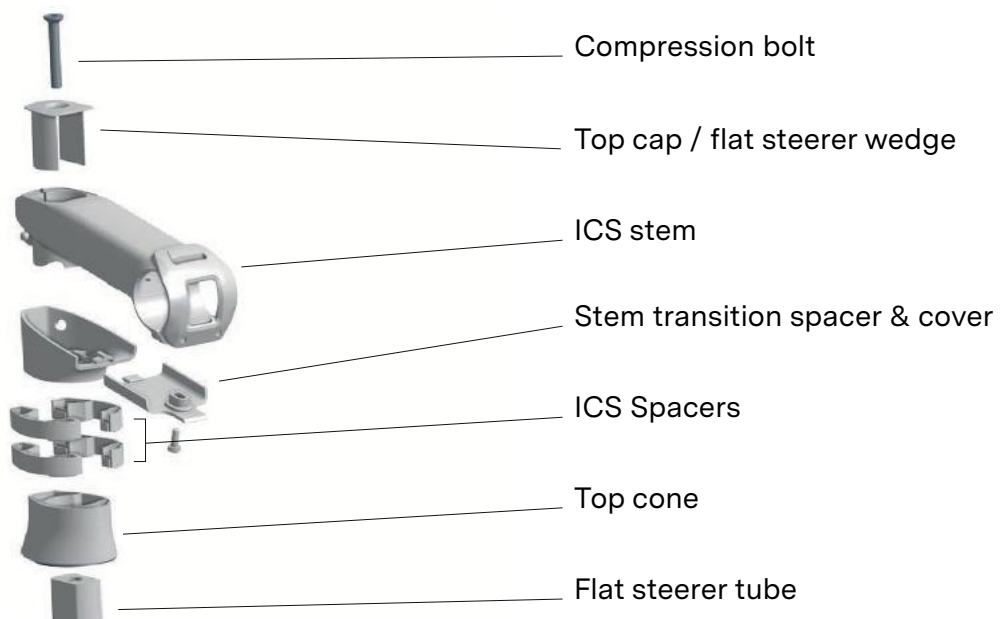

**RSM01 with ICS Core**

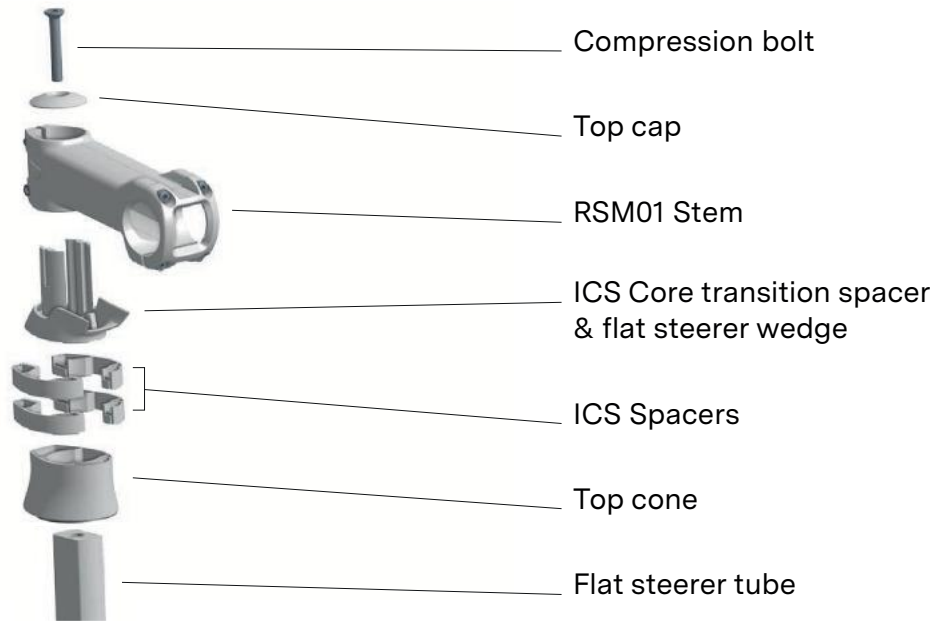

## Headset Compression and Clamping the Stem

- Once the frame and fork are assembled with the headset, spacers, stem or cockpit, and top cap, torque the preload bolt to 4 Nm.
- Refine the handlebar-wheel alignment using the slight rotational freedom provided by the ICS system.
- Torque the stem/cockpit bolts as indicated on the stem/cockpit or according to the torque values provided below.

**⚠ WARNING:** Correct headset preload is crucial for a safe, play-free steering system.

### ICS Cockpit



### ICS Stem

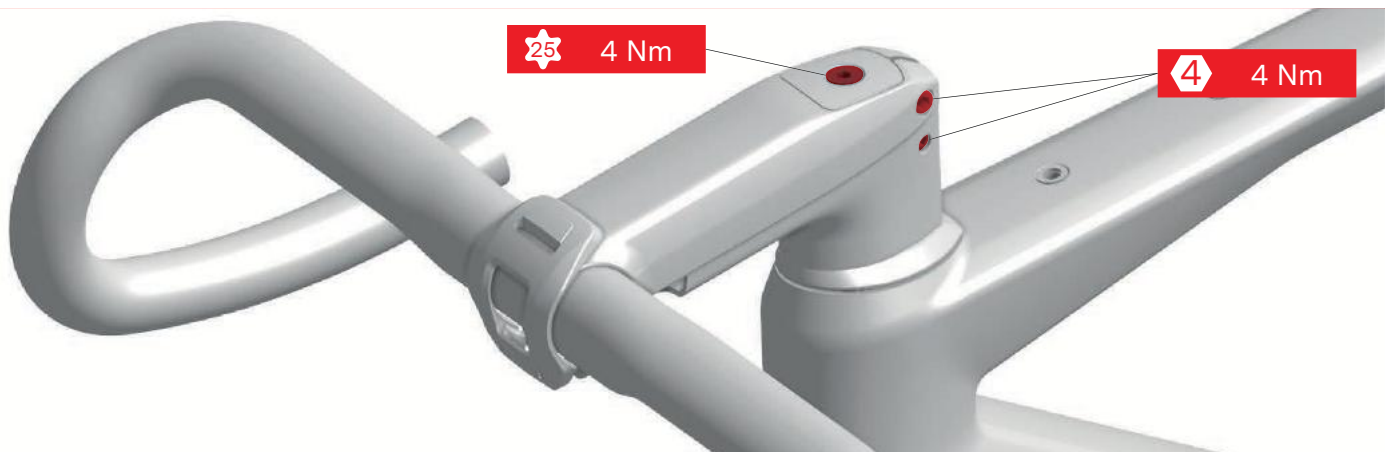

### RSM01 with ICS Core

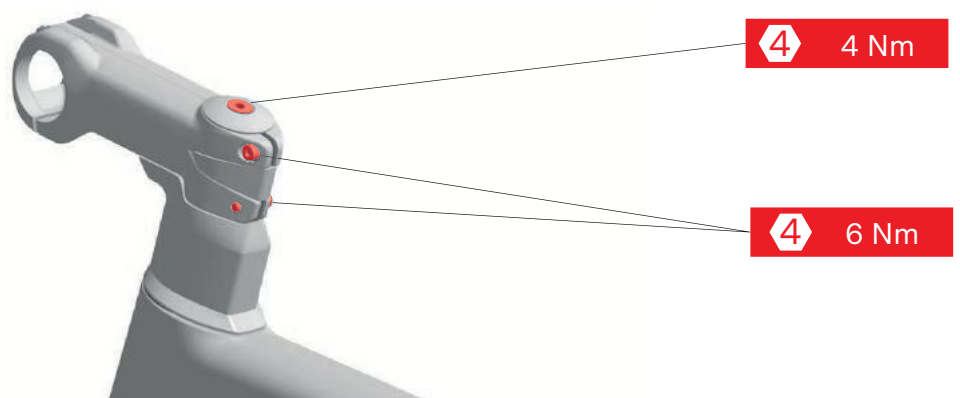

## Bottom Bracket and Crankset Assembly

- Now that all the cables and brake hoses are installed, you can install the bottom bracket and the crankset.

**⚠ WARNING:** Always install the brake hose first.

**ℹ INFORMATION:** The Teammachine SLR uses a Press-Fit 86.5mm bottom bracket.

**⚠ WARNING:** Please follow the bottom bracket and crankset instructions for installation.



## Bottle Cages

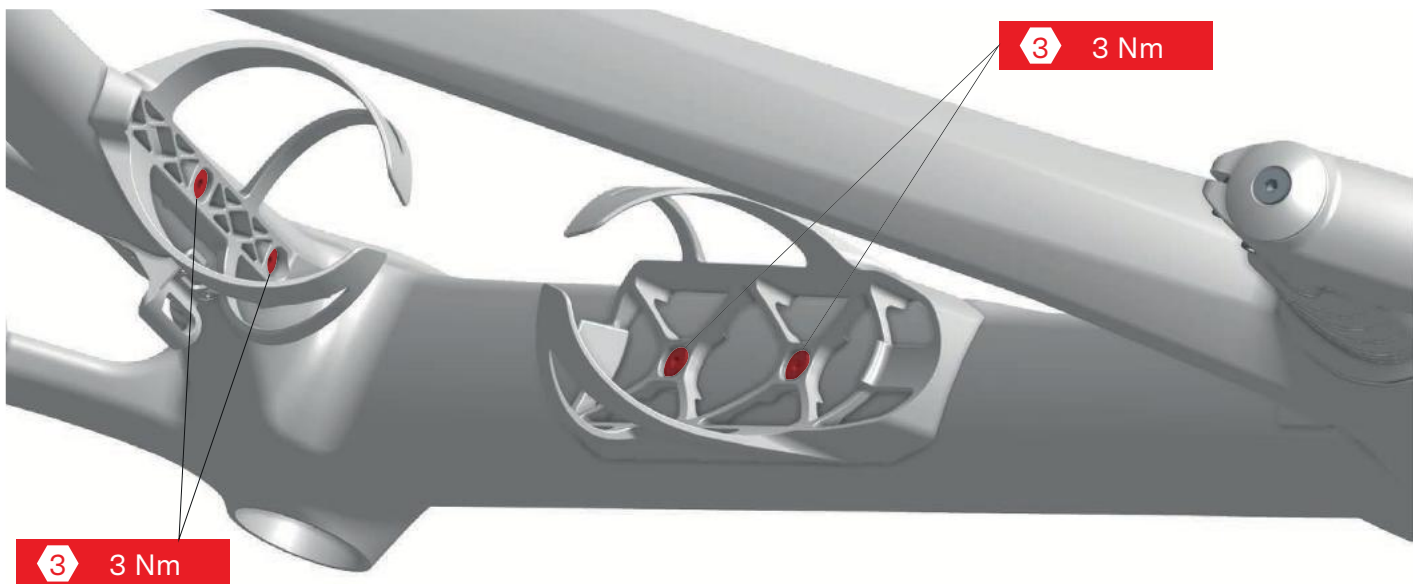

**ℹ INFORMATION:** Teammachine SLR is designed for BMC Aerocore bottle cages. The optional down tube and seat tube bottle cages set is available after-market. Aero Cage Set (30000698). Teammachine SLR is however compatible with traditional bottle cages.

- Install the BMC bottle cages or the bottle cage of your choice.
- Tighten the 2x M5x12 bolts to 3 Nm using a hex 3mm wrench.

## Wheels and Axles

**⚠ WARNING:** Your bike is delivered pre-assembled with inner tubes for transportation and display. Always setup the wheels following the recommendations and instructions of the wheel and the tire manufacturers:

- Some wheels must only be assembled tubeless.
- Some wheels must only be installed with specific tires for a tubeless setup (hookless rims).
- Even if the wheels are tubeless, some tires assembled on some bike models may not be tubeless compatible.
- Please read carefully the tires and the wheels instructions.

**⚠ WARNING:** Make sure tubeless compatibility is guaranteed between your wheels and your tires:

- Minimum and maximum tire size
- Minimum and maximum tire pressure
- Tire bead design (hooked or hookless)
- Rim design (hooked or hookless)

- Grease the thread and the head of the thru-axles.



- Thru-axles must be torqued to 10 Nm using a hex 6mm.

## Fenders

Teammachine SLR is only compatible with quick mount clip-on third party fenders. Engineered to be the lightest, the Teammachine SLR does not feature threads and brackets to install classic fenders using stays bolted on the frame and fork.

Examples of quick mount clip-on fenders

- SKS Raceblade Pro
- TOPEAK Tetrafender R1 / R2
- TOPEAK Defender RC1 / RC11

**⚠ WARNING:** You must carefully install your fenders so they don't damage your frame or its components. Road vibrations could cause the fenders to vibrate and rattle causing paint damage and frame structural damage or components damage. Damage may result in component failure and result in loss of control and falling.

**⚠ WARNING:** Protect the frame by applying protective tape. This will avoid fenders to scratch or damaging the frame's paint or even damaging the frame's structure.

**⚠ WARNING:** Lots of fender options are available on the market. Even if their design is optimized for road bikes, you may have to modify their shape.

**⚠ WARNING:** Tire clearance is affected by the installation of fenders. Always respect a clearance of 4mm all around the tire to guaranty your safety. Depending on your fender choice and installation, you may have to change your tire size to get the appropriate tire-to-fender clearance.

**⚠ WARNING:** Always follow the fender manufacturer's recommendation for installation.

## Quick Mount Clip-on Fenders

You can attach the quick mount clip on fenders on limited areas of the fork blades, seat stays, seat tube and seat post.

**⚠ WARNING:** Avoid fixing systems other than elastic bands or fabric straps. Clamping with clamps or bolt-on mechanism may damage the frame structure.

■ Clamping zones



MEMBER

---

# Service Instructions

The BMC Teammachine SLR is a high-tech, performance oriented product. We ask you to take care of your bike if you want it to deliver its maximum performance over the years.

If you notice parts that are worn out or damaged, do not hesitate to replace the part and or contact your BMC dealer.

## Washing Your Bike

You should never use a high pressure washing device to clean your Teammachine SLR.

Even with a lot of attention to detail, we cannot build a functional bike resistant to high pressure water.

We recommend using a brush and soft bike soap, and rinse with water at low pressure.

Avoid degreaser and brake cleaners directly on the frame, fork and handlebar area. Composite carbon and painted components could be permanently damaged and made fragile.

## After Washing

If there is water trapped in your frame, it should drain automatically from below the bottom bracket.

If the steering does not rotate freely, check the installation of the headset and stem. If the issue is not solved, it may be that your headset bearings need to be replaced.

If your seatpost makes an unusual noise after washing or riding in wet weather, you need to take the seatpost apart, clean the frame seat tube and the seatpost, and reapply carbon friction paste between frame and seatpost.

## Trouble Shooting

### Noise from the saddle or the seatpost:

- Apply friction paste between the seatpost and the frame seat tube.
- Apply grease on each element of the saddle clamp (bolt, washer, clamps).
- Apply friction paste between the seatpost and the frame.

### Noise from the drivetrain:

- Check front and rear derailleur assembly and front and rear dropout hanger assembly. Reapply threadlocker compound on the dropout hanger bolts if necessary and tighten to torque.
- Check rear thru-axle: clean with a degreaser, reapply grease on thru-axle as indicated in this manual and reassemble tightening to the correct torque.
- Check bottom bracket and crankset following instructions from their manufacturer(s).

### Seatpost slipping down:

- Apply friction paste between the seatpost and the frame seat tube
- Disassemble, clean and degrease the seat clamp and grease before reassembly.
- Check the torque at the seatpost clamp and at the saddle clamp.

### Play in the headset:

- Loosen the stem, and tighten lightly the headset compression bolt to 4 Nm.
- Tighten the stem back to the manufacturer's recommended torque.

### Friction in the headset:

- Make sure nothing is stuck between head tube and fork or between the headset top cone the head tube.
- Check the headset bearings and replace them if necessary.

### Play in the stem/handlebar area:

- Do not ride with play in the cockpit or stem/handlebar assembly.
- Check the torque settings of every single bolt.
- Apply grease, thread lock and friction paste as indicated in this manual.
- Check that none of the stem bolts are damaged.



**BMC**