

# 2026 Salsa Blackthorn Alloy Frame - Brushed Raw Aluminum - Geometrical Chart

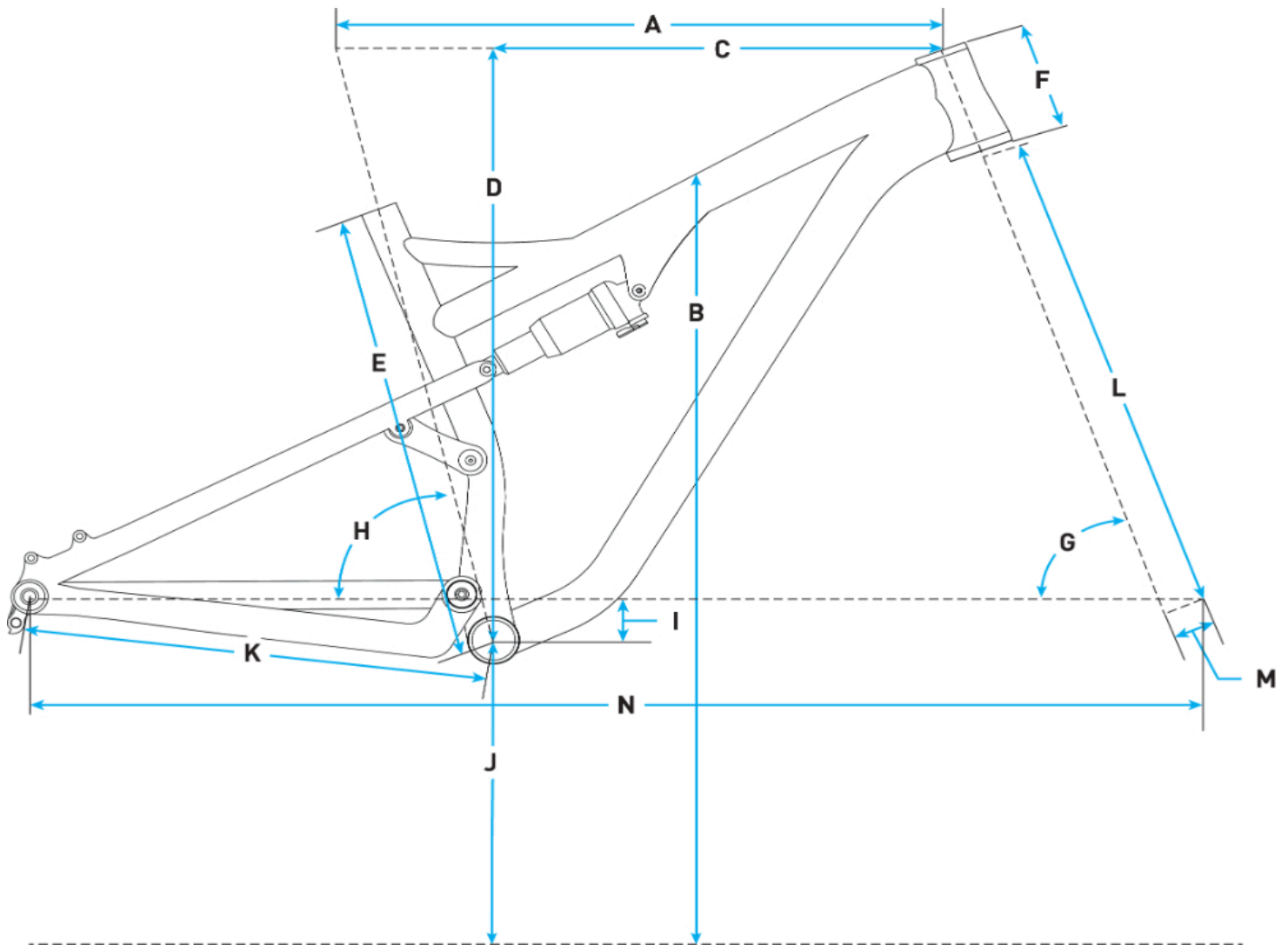

## Metric

Size	Small	Medium	Large	X-Large
<b>A. Effective Top Tube</b>	594.0- 593.0	616.0- 615.0	640.0- 639.0	663.0- 662.0
<b>B. Stand Over</b>	726.0- 728.0	729.0- 732.0	730.0- 733.0	730.0- 733.0
<b>C. Reach</b>	448.0- 451.0	469.0- 472.0	490.0- 493.0	510.0- 514.0
<b>D. Stack</b>	611.0- 609.0	615.0- 613.0	624.0- 622.0	633.0- 630.0
<b>E. Total Seat Tube Length</b>	405.0	430.0	455.0	480.0
<b>F. Headtube Length</b>	95.0	100.0	110.0	120.0
<b>G. Headtube Angle</b>	64.6	64.6	64.6	64.6
	64.9	64.9	64.9	64.9
<b>H. Seat Tube Angle</b>	76.5	76.5	76.5	76.5
	76.8	76.8	76.8	76.8

<b>I. BB Drop</b>	26.0- 22.0	26.0- 22.0	26.0- 21.0	26.0- 21.0
<b>K. Chainstay Length</b>	432.0- 431.0	432.0- 431.0	432.0- 431.0	432.0- 431.0
<b>L. Fork Length Axle to Crown</b>	569.0	569.0	569.0	569.0
<b>M. Fork Offset</b>	43.0	43.0	43.0	43.0
<b>N. Wheelbase</b>	1204.0- 1204.0	1228.0- 1227.0	1253.0- 1252.0	1278.0- 1278.0
<b>Crank Arm Length</b>				
<b>Handlebar Width</b>				
<b>Recommended Rider Height</b>	165.0 - 173.0	173.0 - 180.0	180.0 - 188.0	188.0
<b>Stem Length</b>				

## Imperial

Size	Small	Medium	Large	X-Large
<b>A. Effective Top Tube</b>	23.39- 23.35	24.25- 24.21	25.2- 25.16	26.1- 26.06
<b>B. Stand Over</b>	28.58- 28.66	28.7- 28.82	28.74- 28.86	28.74- 28.86
<b>C. Reach</b>	17.64- 17.76	18.46- 18.58	19.29- 19.41	20.08- 20.24
<b>D. Stack</b>	24.06- 23.98	24.21- 24.13	24.57- 24.49	24.92- 24.8
<b>E. Total Seat Tube Length</b>	15.94	16.93	17.91	18.9
<b>F. Headtube Length</b>	3.74	3.94	4.33	4.72
<b>G. Headtube Angle</b>	64.6	64.6	64.6	64.6
	- 64.9	- 64.9	- 64.9	- 64.9
<b>H. Seat Tube Angle</b>	76.5	76.5	76.5	76.5
	-	-	-	-
	76.8	76.8	76.8	76.8
<b>I. BB Drop</b>	1.02- 0.87	1.02- 0.87	1.02- 0.83	1.02- 0.83
<b>K. Chainstay Length</b>	17.01- 16.97	17.01- 16.97	17.01- 16.97	17.01- 16.97
<b>L. Fork Length Axle to Crown</b>	22.4	22.4	22.4	22.4
<b>M. Fork Offset</b>	1.69	1.69	1.69	1.69
<b>N. Wheelbase</b>	47.4- 47.4	48.35- 48.31	49.33- 49.29	50.31- 50.31
<b>Crank Arm Length</b>				
<b>Handlebar Width</b>				
<b>Recommended Rider Height</b>	64.96 - 68.11	68.11 - 70.87	70.87 - 74.02	74.02
<b>Stem Length</b>				

## Measurements based on:

- an unsprung bike (no sag)
- a 29 x 2.4" tire measuring 746mm in diameter
- Standover is measured from vertically from ground to top of top tube 50mm forward of bottom bracket, subtract 9mm (0.3") for 27.5 x 2.8" tires
- Note: Where two measurements are listed, the first number is with Flip Chip in Low position; the second number is with Flip Chip in High position