

MAHLE X30 System
User Manual

X30

1. Introduction	4	4.1 My SmartBike APP	20
1.1 General warnings	4	4.1.1 Smartphone APP account creation	20
1.2 Safe charging procedure	5	4.1.2 Main features	21
1.3 Use and operation	5	4.1.3 Engine modes	21
1.4 Care and maintenance	5	4.2 My SmartBike web browser	21
1.5 Recycling	5	4.2.1 Web application: main features	21
1.6 Product certifications	6		
2. General description	7	5. Care and maintenance	22
2.1 Main system	8	5.1 Your e-bike care	22
2.1.1 X30 Engine	8	5.1.1 General system care	22
2.1.2 Internal battery	8	5.1.2 Engine care	22
2.1.2.1 iX2 Battery	8	5.1.3 Battery care	22
2.1.2.2 iX3 Battery	8	5.1.4 Active charger care	23
2.1.3 Control unit	8	5.2 Your e-bike maintenance	23
2.1.4 Charging port	8	5.2.1 Rear wheel maintenance	23
2.1.5 Peddling sensor	9	5.2.2 Free wheel and bottom bracket maintenance	24
2.1.5.1 Torque/cadence sensor	9	5.2.3 Battery, engine and main unit maintenance	24
2.1.5.2 Cadence sensor	9	5.3 Transporting your e-bike	25
2.1.6 Engine connector X30	9	5.4 Warranty	25
2.1.7 Active charger	9	5.5 Frequently Asked Questions	25
2.2. Accessories	10		
2.2.1 Pulsar ONE	10	6. Diagnostic codes	27
2.2.1.1 Pulsar ONE Brackets	10		
2.2.2 Electronic shifters	10		
2.2.2.1 Installation of e-Shifters	11		
2.2.3 Duo	11		
2.2.4 External battery	12		
2.2.4.1 Elements of the external battery pack	12		
2.2.4.2 External Battery eX1 cables	12		
2.2.4.3. Energy Hub	13		
2.3 Compatible e-bikes	13		
3. Use and Operation	14		
3.1 Use	14		
3.1.1 Before first use	14		
3.1.2 Intended use	14		
3.1.3 Prohibited use	14		
3.2 Operation	14		
3.2.1 Operating status	14		
3.2.2 Switching the system on and off	15		
3.2.3 Levels of assistance	15		
3.2.4 Pedal assistance mode	16		
3.3 Control unit information	16		
3.3.1 Battery charge level	16		
3.3.2 Current level of assistance	17		
3.3.3 Adjusting LED intensity	17		
3.3.4 Other information displayed by the control unit	18		
3.4 Functioning of the active charger	18		
3.4.1 Active charger X30	18		
3.4.2 Charging process	18		
3.5 Lights	19		
3.6 Update process	19		
4. Application and services	20		

1. Introduction

Thank you for choosing the MAHLE X30 system for your new SmartBike. Please read this manual carefully before operating the system. Failure to do so or to understand the instructions may result in serious injury or death.

This document is drafted in Spanish, as laid down in EN82079-1, and its content shall prevail in the event of any translation error or misunderstanding in the interpretation of its translations by the client.

The product and specifications are subject to change without notice.

This manual includes instructions for the X30 system, which consists of the following elements:

- Engine
- Battery
- Control unit
- Charging port
- Torque/cadence sensor
- Cables and adapters
- Active charger

All relevant X30 system documents, including this user manual, as well as the different hardware, software and firmware versions of its components, can be found on our website: mahle-smartbike.com

The elements of the X30 system are certified as a comprehensive product to ensure total safety and can only be replaced with original spare parts from MAHLE SmartBike Systems, hereinafter referred to as MAHLE, to continue to guarantee the safety of the entire system. Any manipulation, modification or repair by a third party not authorised by MAHLE will automatically invalidate the warranty terms and the original certification, as well as exempt MAHLE from any criminal or civil liability.

This manual may not be reproduced in any form other than in its entirety, except with the prior written approval of MAHLE.

Only certified suppliers of MAHLE may undertake repairs or replacements.

If you have any questions regarding the X30 system, please contact your local supplier or MAHLE Smartbike Systems SLU at: mahle-smartbike.com/contact/

1.1. General warnings

This manual contains DANGER, WARNING and CAUTION notices concerning the consequences of failure to use, install, maintain, store, inspect and dispose of MAHLE e-Bikes (Electric Bikes) safely. The combination of the safety alert symbol and the word DANGER indicates a hazardous situation which, if not avoided, may result in death or serious injury. Please observe all warnings and safety instructions in the future and do not open the engine or the battery yourself. Furthermore, the system is maintenance-free and should only be opened and repaired by qualified experts using original spare parts and specific tools, as unauthorised opening of a system will invalidate the warranty. All parts of the engine and e-Bike may only be replaced by identical parts or parts specifically approved

by the manufacturer of your e-Bike in order to protect it from damage. Do not modify the engine, battery or any other element, or add any other non-approved products to improve performance or handling, as there is a risk of accident in the event of accidental activation. On the other hand, please take care when touching the surface of your engine, as it may become very hot and cause skin burns. The pedal assistance feature can only be used when riding the e-Bike and requires the use of specific controls. If the wheels are not in contact with the ground when using this function, there is a risk of injury. Only use original MAHLE batteries approved by the e-Bike manufacturer, as the use of unauthorised batteries can cause injury or fire. Finally, please observe regional and local regulations regarding e-Bikes and Pedelecs (Pedal Electric Cycle).

Please pay particular attention to any warning symbols highlighted with these graphics that appear on the system.

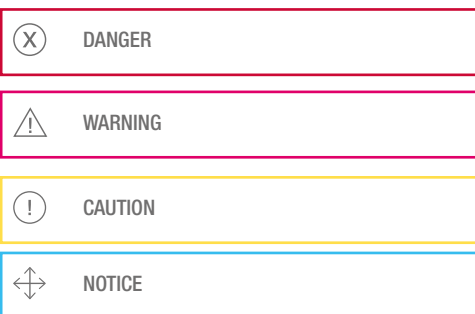

1.2. Safe charging procedure

Before using your e-bike for the first time, please read the guidelines for safe battery charging and handling carefully.

The X30 system includes an intelligent charger that establishes charge management between the internal and external batteries of the MAHLE X30. This charger provides the correct charging current and ideal cell balancing.

Only use original MAHLE chargers to charge the range extenders or internal batteries of the X30 system and ensure that the battery and charger are compatible. Both the charger and batteries are fully qualified for use under current regulations in regions where the X30 system is approved for use.

- Connect the charger directly to a power source and do not use extension cords.
- Do not perform reverse charging.
- Do not use the active charger with non-rechargeable batteries, there is a risk of overheating and fire.
- The active charger is not designed to charge car batteries.
- Before each charging process, check the charger, the charging cable and the charging plug for any damage.
- Do not cover the charger during the charging process.
- Check the battery regularly and never charge a battery that may be damaged or defective.
- Make sure that the socket and plug are not wet or damp before connecting and charging the battery, which may occur when cleaning your bicycle.
- If the e-Bike or the battery pack is too cold, wait until it warms up before charging the system.
- Before first use, make sure that the battery is fully charged.



WARNING

Batteries contain flammable gases. Avoid open flames and sparks. Ensure adequate ventilation while charging. The charger is intended for indoor use only. Improper use of other batteries may cause explosions resulting in personal injury and property damage. Do not burn, disassemble or short-circuit batteries.

1.3. Use and operation

Please refer to the specific section on the use and operation of your e-bike before using your X30 system.

1.4. Care and maintenance

Refer to the specific section on care and maintenance of your e-bike before carrying out any of these tasks.

Please note that only official MAHLE services may carry out maintenance, replacement and repair of certain system components. In the event of a repair, the MAHLE Service Department must approve the process.

Note that the capacity of a battery deteriorates over time. During normal use for 2 years or after 500 full charge cycles, the battery may degrade to about 70% of its initial capacity, requiring replacement to regain 100% capacity.

1.5. Recycling

Please ensure that the various components of the system, as well as the packaging elements, are recycled correctly. Pay special attention to the battery, especially when it reaches the end of its service life. To do so, please contact your dealer or the e-Bike manufacturer to ensure that the recycling process is correct. If you need to replace the battery, please note that only official MAHLE service technicians are authorised to replace the internal battery and to recycle the old one.

In compliance with European Regulation 2012/19/EU, electrical devices or systems that are no longer in use must be properly recycled and disposed of in an environmentally friendly manner. This product must be deposited at an authorised recycling point for electrical and electronic components. Please also take into account the regional regulations in your country.

The process of waste separation, management and disposal must comply with current legislation. Dispose of batteries and rechargeable batteries according to the specific regulations in your region.

MAHLE Smartbike Systems, S.L.U. is registered with the Spanish Government for waste management under RII-PYA 2575, RII-AEE 8233 and ENV/2023/000030717 in compliance with EU Directives 2013/56/EU, 2012/19/EU and 2019/904/EC, respectively.

1.6. Product certifications

MAHLE Smartbike Systems SLU declares that the X30 system or components of the X30 system to which it applies comply:

EUROPE:

With the harmonised standard EN15194:2017, the European Directives 2006/42/EC, 2014/30/EU, 2014/53/EC, 2006/66/EU, 2014/35/EU and the POP Regulations RoHS and REACH. Noise emissions do not exceed the limits set by current European legislation.

USA and CANADA:

With the ANSI /CAN/ UL 2849:2020 standard, in the US with Title 15 Chapter 47 Section 2085 of the Code.

Moreover, this equipment has been tested and found to comply with Part 15 of the FCC rules in the USA and with RSS-102, RSS-247 and Canadian radiation exposure limits for uncontrolled environments set forth in CAN IC-ES-3(E)/NMB-3(b).

The full text of the EU Declaration of Conformity and other relevant documentation of the system for certification purposes is available on the following website:
<https://mahle-smartbike.com/conformity>



CAUTION

In the event of substantial assembly, changes or modifications that have not been expressly approved by the manufacturer, the certification of the system shall be cancelled. The person who has carried out such assemblies, changes or substantial modifications shall be liable for recertifying the system.



WARNING

Some parts of the system may contain chemicals known to the State of California to cause cancer, birth defects and reproductive harm.



2. General description

You have purchased an e-Bike that includes a MAHLE X30 SmartBike system designed to assist you while pedalling according to your country's regional regulations for this activity. The X30 system consists of the following components. Some of these components have a specific manual which can be consulted at <https://mahle-smartbike.com/downloads/>

1 X30 Engine



2 IX2 / IX3 Internal Battery



3 Control unit



4 Charging port



5 Torque/cadence sensor



6 Cables and adapters



Accessories

A Pulsar ONE Display



B eShifters / Duo

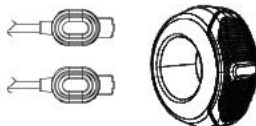

C External Battery eX1

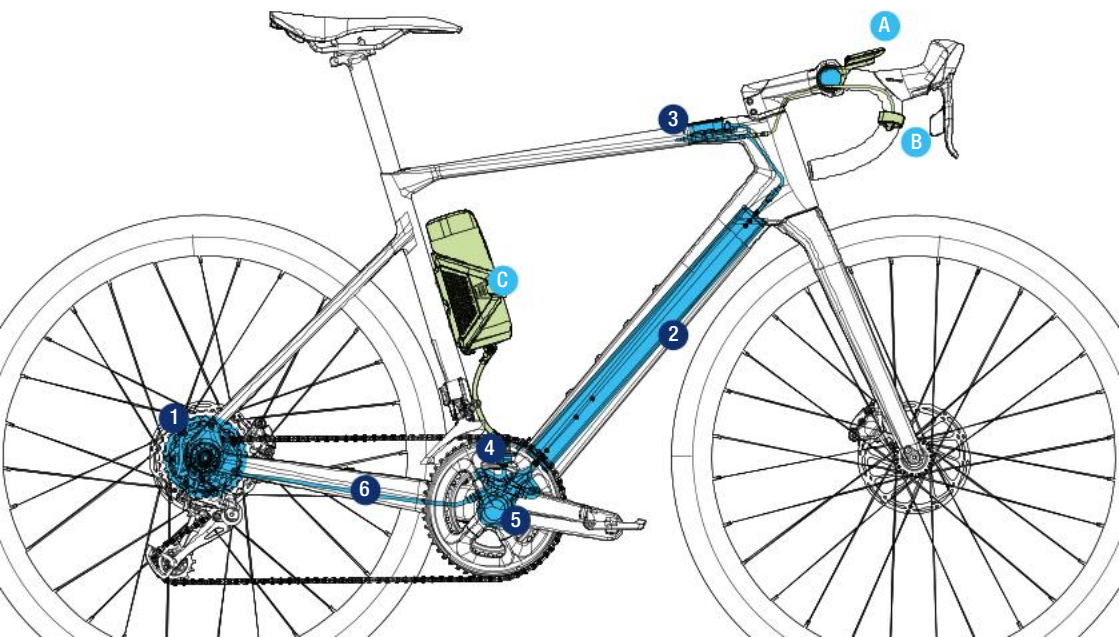

2.1. Main System

Protection Against Dust and splashing water in general, except where otherwise indicated.

2.1.1. X30 Engine

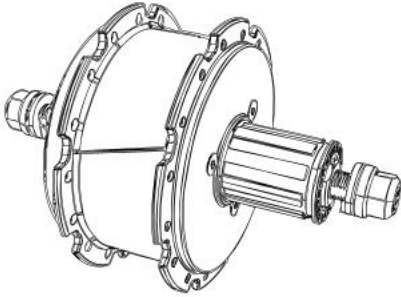

- Engine with torque equivalent to that of a 45 Nm mid-engine.
- O.L.D. Axis 136.5 mm.
- Rated voltage: 36 V.
- Max. speed: 25 km/h or 20 mph (limited by region).
- Motor connection system by means of a watertight connector.
- Standard free wheel installation.
- CAN-BUS interface.
- Weight: 1,900 g (without core).

2.1.2. Internal Battery

There are two internal battery options for the MAHLE X30 system depending on their charging capacity.

2.1.2.1 iX2 Battery

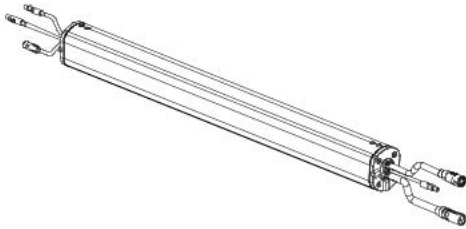

- Capacity: 236 Wh.
- Rated voltage: 36 V.
- Maximum charge current: 3.2 A.
- Measurements: 469.5 x 49.6 x 41.8 mm.
- CAN-BUS interface.
- Energy support for accessories: 2A (maximum) / 12 V (maximum).
- Weight: 1,500 g.

2.1.2.2 iX3 Battery

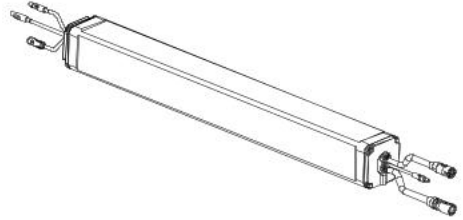

- Capacity: 350 Wh.
- Rated voltage: 36 V.
- Maximum charge current: 4 A.
- Measurements: 469.5 x 51 x 52 mm.
- CAN-BUS interface.
- Energy support for accessories: 2A (maximum) / 12 V (maximum).
- Weight: 2250 g.

2.1.3. Control unit

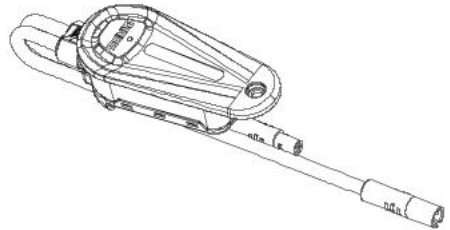

- Action button.
- Light sensor.
- Measurements: 73.1 x 28.2 x 18.9 mm.
- Dynamic RGB LED interface.
- CAN-BUS, ANT+ and Bluetooth® interface.
- Temperature of use: -10 °C to 60 °C.
- Weight: 32 g.

2.1.4. Charging port

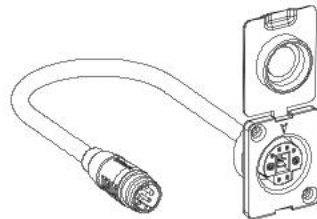

- 6-pin connector with single connection.
- Weight: 24 g.

2.1.5. Pedal sensor

The X30 system has two ways of monitoring the cyclist's pedalling.

2.1.5.1 Torque/cadence sensor

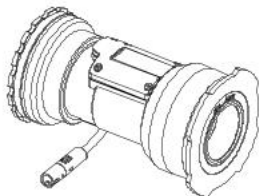

- Torque/cadence reading.
- Designed for BB snap-on housings.
- 4 different models available.
- Compatible with all spindles on the market.
- Mixed press-fit and threaded mechanism.
- Digital interface.
- Weight: 159 g.

2.1.5.2 Cadence sensor



- Magnetic cadence sensor.
- Number of magnets: 20.
- Compatible with Shimano Hiper Glyde cassettes (12v and 10/11v).

2.1.6. Engine connector X30



- Cable length 300 mm.
- Weight: 44 g.

2.1.7. Active Charger

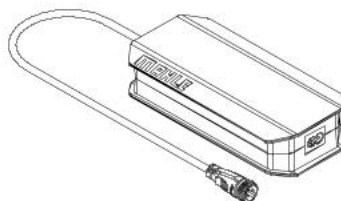

- Input voltage (AC): 90-246 V 50-60 Hz.
- Rated output voltage/current: 42 V – 3.2A / 4A.
- Recommended temperature of use: -15 °C to 35 °C.
- Measurements: 187 x 90 x 44.4 mm.
- Protection against water ingress: IP20.
- Weight: 690 g.

2.2. Accessories

2.2.1. Pulsar ONE

PULSAR ONE is an ANT+ e-Bike computer developed by MAHLE and specially designed for use with ANT+ compatible MAHLE systems (X35+, X20 or X30). It connects wirelessly to the e-Bike system via the ANT+ LEV (Light Electronic Vehicle) communication protocol. All new MAHLE systems are fully compatible with this protocol.

The 2.1" wide display enables you to view essential information about your e-Bike system, such as battery level, assistance level, light status, range and errors, as well as basic riding information such as speed or time. This information is complemented with other essential data for any cyclist, such as average speed, maximum speed, ride time, distance travelled, e-Bike odometer, heart rate, cadence, etc.

Pulsar ONE Display
SKU: 33010000000000

Includes screen, screen protector, CR2032 battery and user manual.

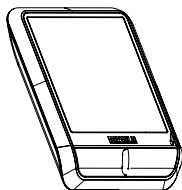

- 2.1" black and white LCD with 3 buttons.
- Wireless connectivity via ANT+.
- Battery type CR2032 (included).
- Certifications (CE, FCC, IC, KCC, Telec and RCM).
- ANT+ LEV, HR, CAD, PWR, CTF.
- Dimensions 57.7 x 41.1 mm.
- Weight 28 g (with CR2032).



NOTICE

You can use the buttons on the display to control the assistance levels and lights. For more information on this product, please refer to the Pulsar ONE user manual.

2.2.1.1. Pulsar ONE Brackets

Two optional brackets are available to place the screen in 4 different positions. Other GARMIN compatible device media can also be used. To ensure a safe installation, make sure you use a bracket compatible with your Pulsar ONE display:

Pulsar ONE Sport Bracket
SKU: 33010000001000

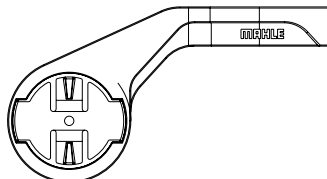

Pulsar ONE Urban Bracket
SKU: 33010000002000

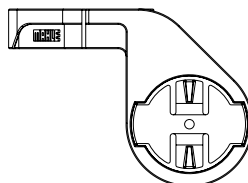

2.2.2. Electronic shifters

The electronic shifters, also known as e-Shifters, are a set of 2 small optional buttons connected to the main unit that enable the features of the MAHLE SmartBike system to be controlled directly from the handlebars (assistance level, lights, etc.). Their minimalist design enables them to be installed regardless of the handlebar used (road or flat).

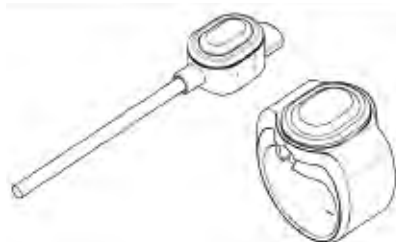

Long or short presses on the shifts enable different commands to be sent to the system and a maximum of 2 e-Shifters can be installed per e-Bike (left and right).

The e-Shifters give haptic feedback to the rider by vibrating (under patent) every time the state of the system is changed so as not to divert attention from riding.

The use of these electronic shifters can help to increase riding safety by avoiding taking your hand off the handlebars. In addition, the vibration provides additional information to the rider when the APP or e-Bike system changes status or reports an alert.

To upgrade the e-Shifters on your X30 equipped bike, please contact your local dealer to ensure proper installation and connection to the X30 system. The following configurations are therefore available:

720 e-Shifters

SKU: 3501000000200

Box + Y-Joint + 2 e-Shifters with 720 mm cable + 2 silicone bands + manual.

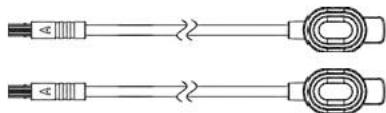

970 e-Shifters

SKU: 3501000000300

Box + Y-Joint + 2 e-Shifters with 970 mm cable + 2 silicone bands + manual.

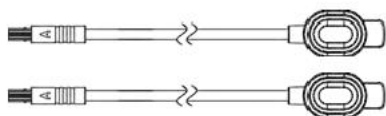

2.2.2.1. Installation of e-Shifters

Installation is possible on various areas of the handlebars and in different ways. In addition, the included rubber covers can be used for installation, but without them, the shifters can be installed under the handlebar tape on road handlebars.

The ergonomic design of the e-Shifters and rubber covers enables them to be perfectly positioned and easily accessible.

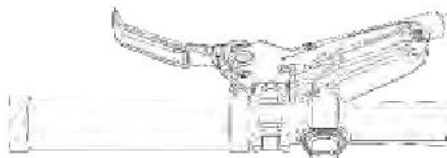
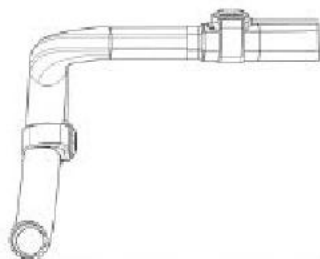

2.2.3. Duo

Two-button wired control handlebar-mounted control unit. It enables the easy change the level of assistance, controlling the lights and activating the walk mode. Installation is optional and can be done on both sides of the handlebar.

Duo

SKU: 36000000000001

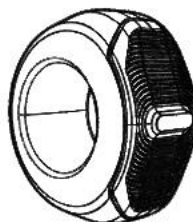

- For 22.2 mm handlebars.
- Dimensions 19 x 43.6 mm.
- Weight: 40 g.

2.2.4. External Battery

The External Battery eX1 (e185) is our latest generation external battery and can be incorporated into the X30 system. The External Battery operates as a stand-alone battery that supplies its power directly to the engine without any interference from the main battery. In addition, with the new My SmartBike application, it is now possible to customise the power consumption of your e-Bike between the main battery and the external battery.

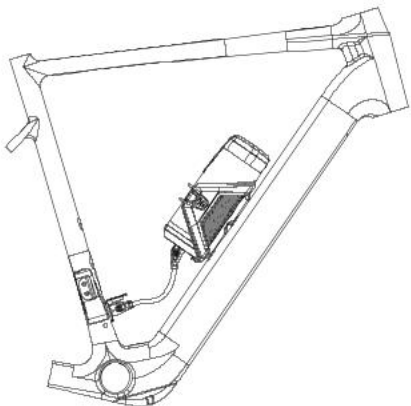

The external battery has an additional 171 Wh and enables a considerable increase in battery life, while adding only 1.1 kg of additional weight to the system. On the other hand, the new holder designed for the External Battery eX1 follows the design, size and mounting points of a normal bottle cage and can therefore also be used to carry a normal bottle when not in use.

2.2.4.1. Elements of the External Battery eX1 Package

The External Battery eX1 pack includes:

External battery eX1

SKU: 41010400000000

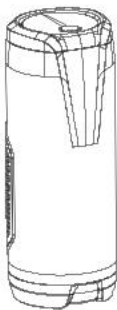

- Capacity: 171 Wh.
- Weight 1,100 g.

Bracket

SKU: 24010414300000

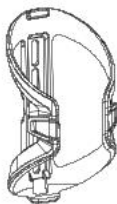

- Compatible with standard water bottles.
- 4 slotted holes of 15 mm (64 mm standard spacing).
- Weight 46 g.

Rubber (to lock the bracket)

SKU: 24010414301000

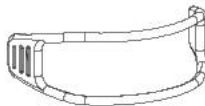

2.2.4.2. External battery cable

Due to the different frame designs, the External Battery eX1 is sold without connecting cables. However, there are two versions of the connection cable, enabling two different installation positions for each cable. When purchasing, check with your bike manufacturer to make sure you choose the correct one that will not interfere with your cranks when pedalling.

AD RA2 30° Connector

SKU: 24010411000000

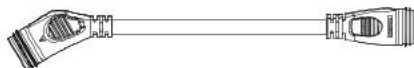

AD RA2 90° Connector

SKU: 24010411001000



2.2.4.3. Energy Hub

Energy Hub is a high power digital charging device, up to 100 W, that enables you to share the energy stored in your External Battery eX1 with any other device via USB-C connection, as well as charge your External Battery eX1 via USB-C connection using a wall charger.

Energy Hub

SKU: 27010400000000

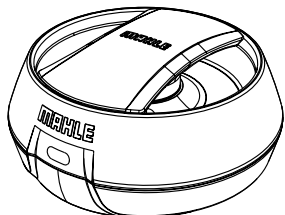

- Input voltage: 9 V-3A, 15 V-3A, 20 V-5A / 100 W MAX.
- Output voltage: 5 V-3A, 9 V-3A, 15 V-3A, 20 V-5A / 100 W MAX.
- IP20 water resistance.
- Weight 119 g.

2.3. Compatible e-bikes

The X30 system can only be mounted on e-bikes that have been designed for the integration of X30 components. A post-sale or retrofit application is not possible. The e-Bike needs to pass all certifications and approvals required by the specific regions in which it will be sold. For an up-to-date list of e-Bikes on the market with our X30 system, please refer to the official MAHLE SmartBikes website:

mahle-smartbike.com

3. Use and operation

Thank you for purchasing an e-Bike that includes the MAHLE X30 system. This system includes a wealth of connectivity features, as well as AI functions, which will give you the opportunity to enter the world of the new Smart-Bikes. This section describes how to use the system and should be read before operation.

3.1 Use

3.1.1. Before first use

For proper operation, make sure that the e-Bike system, including the rear wheel, is completely connected and correctly mounted.

Make sure that the e-Bike is fully charged before the first use and for this purpose, we recommend keeping the e-Bike system connected to the power supply and the Active Charger for as long as required until charging is complete. For additional information on how to charge your e-Bike, please refer to the section "Operation of the active charger/Charging process".

Before you start riding, always make sure that the battery is sufficiently charged, that the active charger of your e-Bike is switched off and switch the system on by pressing the button on the main control unit once. Never use the e-Bike during the charging process.

3.1.2. Intended use

The intended use of our product is to assist the pedalling of an EPAC (Electronic Power Assisted Cycling) bike and not for any other e-Bike application. All elements of the X30 have been designed to be integrated into a comprehensive e-Bike made by a professional bike manufacturer.

Our product is designed according to the requirements established by the regulations for use in EPAC systems and to certain environmental conditions in which this type of system can be used, such as rain, saline areas, mud, etc.

3.1.3. Prohibited use

It is not permitted to integrate our system on a non-compatible EPAC that has not been certified as such according to EN 15494 or on a normal bicycle. Tampering with the legal parameters (speed or power), repairing the battery or reusing it for any other system or EPAC is a violation of MAHLE regulations. Moreover, tampering with our components, changing the software and firmware designed and approved by MAHLE, or adding electronic components that change the maximum assistance speed is a violation of MAHLE regulations. If the MAHLE standard is impaired by non-compliance with the above, MAHLE accepts no legal liability for personal injury or damage to property.

The MAHLE system reserves the right to include features that can analyse and record any kind of anomalous behaviour caused by system manipulation, such as a maximum speed that is too high or anomalous data communication. Any tampering will immediately void all MAHLE warranty terms.

It is strictly forbidden to integrate our system on a bicycle, even if it is compatible, that does not have a CE marking.

Tampering with the legal parameters (speed or power), repairing the battery or reusing it for any other system or EPAC is a violation not only of MAHLE standards but also of current legislation, as is tampering with our elements, changing the software and firmware designed and approved by MAHLE, and adding electronic elements that modify the maximum assistance speed.

MAHLE accepts no liability for personal injury or damage to property or for any circumstances that may occur on a bicycle that is not CE marked.

3.2 Operation

3.2.1. Operating status

The system has three different operating statuses:

- **Normal:** everything is correct. The systems show the charge level and the current assistance level.
- **Warning:** the control unit line flashes orange. Although some events have occurred in the system, driving and assistance are not limited.
- **Error:** the control unit line flashes red. There is a malfunction that limits assistance.

If warning (orange light) or errors (red light) occur, the system sends a diagnostic code via Bluetooth® and ANT+LEV to identify the event in detail. To view this code, link your phone using the MAHLE My SmartBike app or via the Pulsar ONE screen. The diagnostic code number shall be displayed. The list of diagnostic codes is attached at the end of this document.

3.2.2. Switching the system on and off

- **Switching the system on.** Press the button on the main unit once to turn on the system. The LED on the main control unit will light up and a welcome animation will be displayed. If everything is correct, the LED will show the battery charge status in white.
- **Switching the system off:** To turn off the system, simply press and hold the button on the main unit for 2 seconds until the LED shows a goodbye animation, after which the LED will turn off.
- **Switching the system off automatically:** When there is no speed and the phone with the app is not connected to the e-bike, the system will automatically shut down after 5 minutes to save battery power. The system can be switched on again at any time by following the normal procedure. This automatic shut-down process also occurs during the charging process when the internal battery reaches 100 % charge.

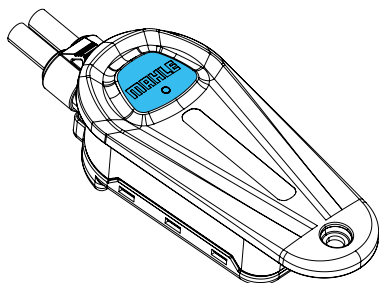

3.2.3. Assistance levels

The system's engine provides pedalling assistance to the cyclist. There are different levels of assistance which differ in peak power, acceleration and reactivity they offer. The levels of assistance can be changed using different methods:

- **Through the main control system.** To increase the level of assistance, briefly press the button on the main control unit and the level of assistance will increase. Once the highest level of assistance has been reached, the system will restart the unassisted cycle by pressing the button.

- **By means of the electronic gears:** The system will enable the optional addition of electronic shifters. These changes are based on 2 small micro-buttons that can be installed on the handlebars. If these 2 remote buttons are connected to the main control unit, you can additionally control the e-Bike assistance by using them when the system is switched on.

Operation	Action
Short press of left button	Decrease assistance
Short press of right button	Increase assistance
Hold down left button	Nothing
Hold down right button	Activate "Walk" mode

- **Control the level of assistance via the Pulsar ONE display:** You can use your X30 system with the Pulsar ONE wireless display that shows all the information: speed, current assistance level, battery charge level, time, distance, power, etc. Pulsar ONE and your e-Bike communicate automatically via ANT+. The Pulsar ONE display includes 3 buttons: a small one in the centre and two large ones on each side, so, with this accessory, you can also control the assistance of your e-Bike when it is on using the left and right buttons of the Pulsar ONE display.

Operation	Action
Short press of left button	Decrease assistance
Short press of right button	Increase assistance
Long press of left button	Turn the lights on/off
Long press of right button	Nothing



NOTICE

Before the bike is switched off, the system saves the last selected assistance level, but if an error occurs before the bike is switched off, the assistance level will be 0.

- **Through the Duo control unit:** You can operate your X30 system with the Duo control unit. This controller and your e-bike communicate via cable. The controller is connected to the e-bike system via cable and consists of two buttons, one at the top and one at the bottom.

Operation	Action
Short press of top button	Increase assistance
Short press of bottom button	Decrease assistance
Long press of top button	Turn the lights on/off
Long press of bottom button	Activate walk mode

NOTICE

The e.Bike manufacturer can set up or change the functionality of the left and right remote buttons in the case of electronic shifting, or top and bottom in the case of the Duo control.

This functionality is set by default during the manufacturing process. For more information on this product, please refer to the manual included in the electronic exchanges or download it from the website: mahle-smartbike.com.

NOTICE

Remember that the driving assistance mode should only be used when moving on foot, without being mounted on the bicycle, with both hands holding both sides of the handlebars and with two wheels in contact with the ground to avoid injury.

NOTICE

The manufacturer may modify the functionality of the right and left buttons. Check the manual for your specific model for detailed information. If you hold the button down for longer, you can control both the pedal assistance and the lights.

Due to some particular regulations, the original manufacturer may configure the e-Bike status lights when starting up the system.

3.2.4. Pedal assistance mode

This mode enables you to get assistance from the engine when you have to push the bike while walking and with both hands holding the handlebars. This helps, for example, when cycling in areas that are not very cycle-friendly. To use the walk assist mode (Walk mode), a remote electronic shifter or an external remote control (Duo) is required to enable it to function correctly.

To activate the ride assistance, press and hold the right button on the electronic shifter, but please note that the bike manufacturer can always customise the functionality of the electronic shifting.

The maximum speed of the driving assistance is 6 km/h (approximately 3.5 mph) and if exceeded, the driving assistance will automatically switch off. The driving assistance will also be switched off when the button is released.

The colour of the current assistance level will be displayed on 50% of the LED bar, when the walk mode is active. This animation will be visible as long as the mode is active.

3.3. Control unit information

The main control unit will constantly inform you about the two most important parameters:

- Battery charge level
- Active assistance level

- 1 Control button
- 2 Ambient light sensor
- 3 Dynamic RGB light
- 4 Adjusting screw

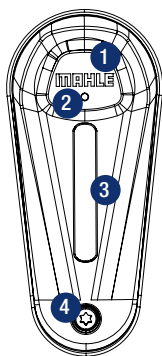

3.3.1. Battery charge level

The main unit will display the current battery level (SOC State Of Charge) by means of the visible length of the LED bar. 100% capacity is represented along the whole line, but as the battery is gradually depleted, the illuminated length of the LED bar will decrease representing the decrease in capacity. However, the LED bar will always keep a minimum of one LED illuminated in order to show the level of assistance used.

The LED line is generated by 7 LEDs that can create visual effects and animations. For the charge level and the length of the illuminated LED bar, the reference is as follows:

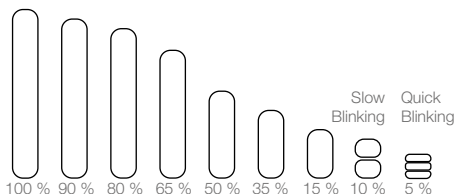

Illuminated LEDs	Charge level
#7	94 - 100 %
#6	82 - 93 %
#5	70 - 81 %
#4	56 - 69 %
#3	36 - 55 %
#2	16 - 35 %
#1	0 - 15 %
#1 (Slow blinking)	0 - 10 %
#1 (Quick flashing)	0 - 5 %

5 - 10 % SOC - The system gives at most 70 % of the nominal maximum power.

0 - 5 % SOC - The system gives at most 40 % of the nominal maximum power.

3.3.2. Actual assistance level

The system has three different assistance levels that can be customised by the user using the MAHLE My SmartBike APP. In addition, you can activate the "Smart Assist" mode via the app and a fourth level of assistance is then displayed. Each level of assistance is represented by a colour:

Level	Colour
0 - No assistance	White
1 - Minimum	Green
2 - Medium	Orange
3 - Maximum	Purple
4 - Smart Assist (App)	Cyan

3.3.3. Adjusting LED intensity

The main button of the control unit has an integrated light sensor by means of which the control unit will automatically increase or decrease the intensity of the LED line to improve the visibility of the information.

3.3.4 Other information displayed by the control unit

The battery status and the level of assistance are shown by the colour and length of the LED bar.

Depending on the status of the e-Bike system, additional information can be transmitted:

The battery status and the level of assistance are shown by the colour and length of the LED bar.

Depending on the status of the e-Bike system, additional information can be transmitted:

Tuning off the bicycle.

A white animation is displayed after the button has been held down for a few moments.

Tuning on the bicycle.

A white animation is displayed after the button has been held down for a few moments.

State of charge during charging.

A cyan-coloured animation with flashing effect is displayed.

Battery charged.

Steady green LED bar.

Bluetooth BLE connected or disconnected.

A blue animation is displayed.

Lights on or off.

A yellow exterior animation is displayed when the lights are switched on.

A yellow exterior animation is displayed when the lights are switched off.

Error.

A flashing red light is displayed when the system has an active error. Switch off the system and make sure that the error has been rectified.



WARNING

A flashing orange light is displayed when the system has an active warning. The use of the system is not prohibited, but the warning should be heeded.

Update in progress.

A flashing pink light is displayed when the software update is performed on the system.

Drive assist mode activated.

The colour of the current assistance level will be displayed on 50% of the LED bar, when the walk mode is active. This animation will be visible as long as the mode is active

3.4. Functioning of the active charger

3.4.1. X30 Active charger

The X30 active charger includes a CAN-BUS communication system. This charger is compatible with all internal batteries of MAHLE's X30 System and extension leads.

The charger enables fast charging up to 4A, using the CAN communication port to identify the battery model and current charge level, supplying the appropriate charge current based on the current charge level.

It includes 2 LED bars to inform about charging mode and status, projecting a backlight against any surface, such as wall or floor.

As an optional feature, a wall bracket is available to attach the charger, keeping the wiring organised when not connected to the e-Bike or while charging.

3.4.2. Charging process

To ensure correct charging, follow these instructions:

1. Connect the charger from the power socket.

The LED on the charger will show a steady white light.

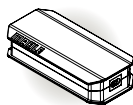

2. Connect the charger to the charging port of the electric bike.

The LED on the charger and the bike control unit will turn cyan.

Breathing effect: from high to low frequency with increasing charge level.

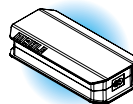

3. Charging process completed

Once charging is complete, the LED on the control unit will display a steady green light.

Disconnect the charger from the power supply before disconnecting it from the e-Bike.

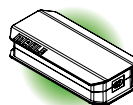

Error in the loading process.

If a critical error occurs during charging, the LED in the charger will flash red.

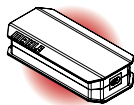

3.5. Lights

The MAHLE X30 system can supply power to a lighting system (optional). Ensure that the lights used are compatible and that you use a MAHLE-compatible remote to activate and deactivate the lights system.

There are 3 modes to control the lights:

- **Automatic mode:** using the ambient light sensor and according to the ambient conditions, the main unit will automatically activate/deactivate the lights.
- **Always on mode:** the lights will remain on whenever the bike is switched on.
- **Manual mode:** the user can take control of the activation of the lights at any time, either via the ANT+LEV screen or using the electronic gear changes if these are installed.



NOTICE

You can change the operating mode of the e-bike via the My SmartBike mobile app or by visiting an authorised MAHLE SmartBike Systems dealer.

Turning the lights on manually

Push and hold the left button on the electronic gear change system or display to turn the lights on. You will see a "lights on" graphic light up in yellow. Next, the LED bar will show the battery level again.

Turning the lights off manually

Push and hold the left button of the electronic gear change system or display to turn the lights off again. You will see a "lights off" graphic in the LED bar. If everything is correct, the LED bar will show the battery level again.

3.6. Update process

Whenever there is an update available, you will be able to update the system through the My SmartBike application in just a few simple steps. Please see this website for more information:

mahle-smartbike.com/activecharger/

4. Application and services

The MAHLE My SmartBike mobile app enables you to connect your mobile device to your X30 system. This application will not only display all the essential ride data and enable you to track and record your activity, but also to customise your assistance levels as you see fit.

MAHLE will continue to add new features and functions to the system to ensure that your bicycle will always be fully compatible with new software applications and intelligent solutions added in the future.

Your X30 system is compatible with the full range of MAHLE SmartBike Systems APPs available on the following platforms:

- iOS: available on the Apple Store
- Android: available on Google Play
- Web: my-smartbike.com

For system diagnostics by professionals (e.g. workshop), we also offer an exclusive dealer application:

- Smartbike Lab (iOS and Android)



NOTICE

To ensure that your X30 system is always up to date, we strongly recommend that you download the My SmartBike app and connect the system to your mobile device. This ensures that your bike is always up to date.

4.1. My SmartBike APP

The MAHLE My SmartBike mobile app enables you to connect your mobile device to your X30 system. This application will not only display all the essential ride data and enable you to track and record your activity, but also to customise your assistance levels as you see fit.



CAUTION

For your own safety, we do not recommend using your mobile device while riding if it is not securely attached to your handlebars.

Use the links below to download the APP.



4.1.1. Smartphone APP account creation

To enjoy all the features of the My Smartbike, create your personal account using one of these two methods:

1. WEB: on a web browser, go to: my-smartbike.com/user/login
2. APP: by downloading the My SmartBike app on a mobile device and following the steps to create an account



Web registration

Once you have created your personal account, open the MAHLE My SmartBike app, turn on your e-Bike and simply follow the process shown on the APP to connect your device with your e-Bike via Bluetooth.



NOTICE

All the information related to the APP can be found in the "tutorials" section of the APP itself. If you have any questions, please check this section.

4.1.2. Main features

If you link your e-Bike to the MAHLE My SmartBike app, you will benefit from the following features:

- Engine performance definition: power control, acceleration and reactivity of each assistance level.
- Log and track your activity and synchronise it automatically with STRAVA. You will also be able to view the activity you have completed online.
- Use your smartphone as the main screen to view your main parameters, such as battery status, heart rate, range, etc.
- Automatic control of the level of assistance (**Smart Assist**).
- Access additional information and tutorials.
- Check the status of your e-Bike.
- Keep your system up to date.
- Records the last position in which the bike was connected to the APP.
- More features will be added soon.

4.1.3 Engine modes

Preset modes.

The X30 system has 3 preset engine modes (Eco, Urban and Sport) and a special self-assist mode (Smart Assist).

Each preset mode is a comprehensive system configuration that will modify the maximum power, acceleration and reactivity of each assistance level (1 to 3). Each of the three assistance modes, Eco, Urban and Sport, are appropriate for different circumstances: power, acceleration and reactivity needs, battery charge, rider weight, terrain inclination, etc.

The system also has a customisation mode that enables you to adjust each of the assistance levels (1 to 3) by setting the maximum power, acceleration and reactivity.

Smart Assist mode.

The special Smart Assist mode is one of our system modes that, based on the inclination of the terrain, the user's weight and power needs, modifies the behaviour of the X30 system, so you can enjoy the ride without worrying about changing assistance modes during the session.

This behaviour is fully personalised for the user, providing the required assistance at every moment of the route. The main parameters involved in this mode are:

- **Peak power:** Peak power defines the maximum power that the engine can achieve during a short period of time (watts).
- **Acceleration:** Acceleration defines the time it takes to reach the full level of assistance selected. A lower % will result in a smoother shift, while a higher % will result in a faster shift.

- **Reactivity to applied torque:** The reactivity defines the effort required to reach the intended socket. A lower % will result in a higher effort, while a higher % will facilitate access to the selected socket.

To find out how to use this mode, please refer to the instructions directly on the APP.

4.2. My SmartBike web browser

You can also view all the details of your e-Bike online on your web browser (on any mobile device or computer). This web application is designed to provide you with more details about your activity and a greater level of monitoring of your overall system usage. To access the website, visit my-smartbike.com and use the same username and password as for the mobile device application.

4.2.1 WEB application: main features

The following features are available on the web application:

- Timetable of all your activities.
- Overview of all your achievements.
- Detailed visualisation of your general use including the use of the different levels of assistance.
- Location of your e-Bike (last position connected to your mobile device).
- Status of your e-Bike (serial number, errors, reports, troubleshooting, components, etc.)
- Complete tracking of your activities, including map overview and power map.
- Segmentation of your ride by elevation, speed, gradient, altitude, heart rate, level of assistance used or power consumed.
- Access to all public activities.
- Synchronisation with STRAVA.
- Sharing of your information on social media.
- Documentation of your system.
- Help.

5. Care and maintenance

The X30 system is designed for prolonged use. There are only a few guidelines to follow to prolong the life of the system.



WARNING

All parts of the X30 system are fully replaceable, but please note that only MAHLE service personnel or authorised MAHLE dealers may change or manipulate certain parts.

Contact the retailer or a bicycle dealer for information on installation and adjustment of products not listed in the owner's manual.

Do not disassemble or modify this product.

Small waterproof connectors are available. Do not unnecessarily repeat switching on and off, as this may impair functionality.

The elements are designed to be fully waterproof to withstand wet weather driving conditions. However, do not deliberately put them in water.

The warranty does not cover natural wear and tear or deterioration of the products due to normal use and the passage of time.

The X30 system can be installed on children's e-Bikes, but do not leave the child unattended and follow the e-Bike manufacturer's safety instructions for this type of use. Cleaning and maintenance should not be undertaken by children without supervision. It is prohibited for children to tamper with the components or the entire e-Bike system.

5.1. Your e-bike care

5.1.1 General system care

Keep your e-Bike system clean and dry.

Never wash any of the components of your e-Bike with a pressure washer or high-pressure cleaning system, because if water gets into any of the components, this can lead to malfunctions or rust, or to safety problems such as fire or explosion. Do not use aggressive cleaning agents for cleaning. If you need to remove mud or other elements, do not use sharp or metallic objects that could damage the surface.

Store your e-bike system in a cool, dry, temperature-controlled place.

The standard environmental conditions of the system are:

- Charging temperature: from 0 °C to 45 °C.
- Discharge temperature: from -20 °C to 60 °C.
- Relative humidity: 65 % ± 20 %.

To ensure the correct charge level, you can check the length of the LED line on the control unit, or connect the Pulsar ONE display or phone app to the bike.

Energy consumption can increase considerably during winter use, especially when the temperature drops below 0 °C. Therefore, fully charge your e-Bike and the external batteries before any winter use and remember that the range of your e-Bike may be reduced.

5.1.2 Engine care

Before cleaning, make sure that the wheel is in the correct position and the connector is fully connected. After cleaning, check that the engine and connector are dry.



CAUTION

When replacing the engine rotor, make sure that the screws meet the following specifications:

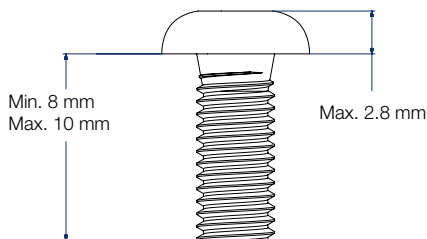

5.1.3 Battery care

The batteries in MAHLE systems use high-quality energy storage cells in order to provide maximum performance. There are a number of guidelines to follow when using batteries to prolong their life. These guidelines are regarding the environmental conditions in which the battery operates, the way the MAHLE system is used, storage, etc.

While standard temperature and humidity ranges and recommended charge levels are set out in other sections depending on the situation, more restrictive criteria and recommended guidelines for extending the life of the various batteries in the system are set out below.

In general

- Full battery charging/discharging can shorten the life of the battery. It is recommended to work in the range of 20 to 80 % of its capacity.
- The optimum relative humidity of the environment is less than 80 %

During discharging

- Optimal discharge temperature range (use): 20 °C to 35 °C.
- Maximum temperature range: -20 ° to 60 °C.

During charging

- Optimum charge temperature range: 20 °C to 35 °C
- Maximum charge temperature range: 0 °C to 45 °C.

During storage

- The optimum storage temperature range is 10 °C to 20 °C.
- In case of prolonged storage, keep the charge level between 20 and 60 %.
- Check the charge level every 6 months and, if required, charge the battery to the previously recommended level.
- Take special care that the battery charge level does not drop below 30 % for extended periods of time.
- Do not store your battery with more than 90 % charge for extended periods of time.
- Do not leave your bicycle in the sun for long periods of time.
- Never expose the battery to high temperatures.

5.1.4 Active charger care

Disconnect the charger and all mains power for any cleaning operation. The charger is intended for indoor use only, so do not expose it to wet, rainy or snowy conditions.

5.2. Your e-bike maintenance

Your X30 system requires regular maintenance and some elements are prone to wear and tear. To ensure that your e-Bike is always working properly, be sure to perform regular maintenance. If you need to replace any of the items, please contact your local dealer for further assistance.

5.2.1 Rear wheel maintenance

The engine of the X30 system is on the rear wheel axle. The electrical connection of this engine is made by means of an adapter cable. When carrying out maintenance or replacement of any of the elements that make up the wheel, the following sections must be taken into account.

Removing the rear wheel

1. If using a single-speed configuration, continue with step 3.
2. If you have a cassette, change to the smallest sprocket.

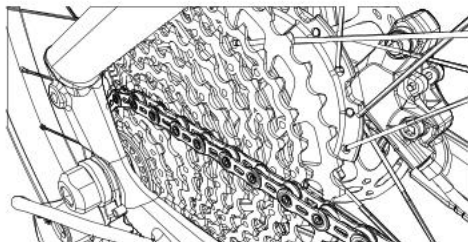

3. Disconnect the engine cable, loosen the nuts on each side of the shaft and remove it.

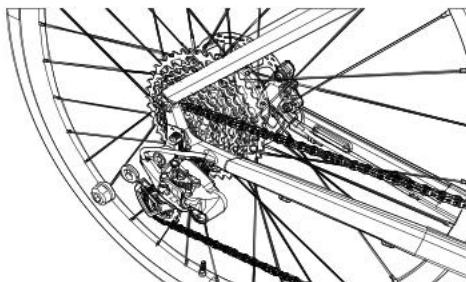
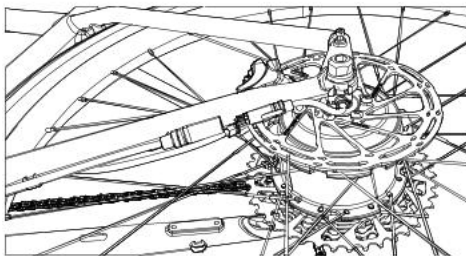

4. Slide the wheel out of the frame, but be sure to give the wheel clearance by pressing the rear shift away from the cassette.

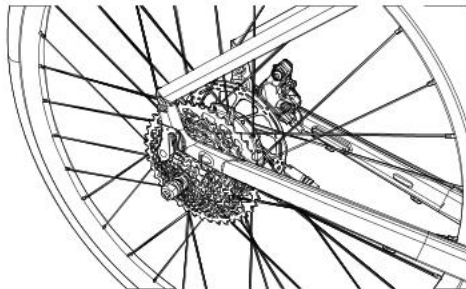

5. Be careful not to damage the frame with the disc rotor by sliding the wheel out of the frame.

Mounting the rear wheel

1. Make sure that the upper part of the chain is over the cassette, while the lower part of the chain passes under the cassette and does not block the shift dropouts.

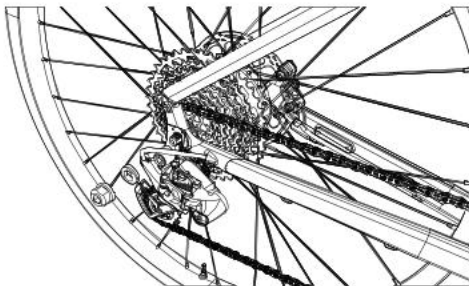

2. Check that both the disc rotor and brake caliper are perfectly aligned to avoid any damage to the frame or brake caliper.

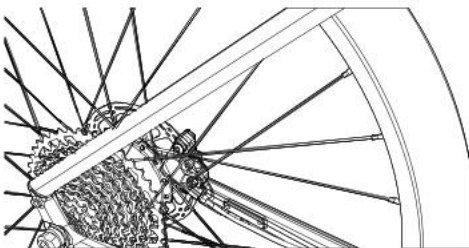

3. Carefully slide the rear wheel into the dropouts. Once the wheel is seated smoothly in the dropouts, tighten the nuts on each side of the axle and connect the engine cable.

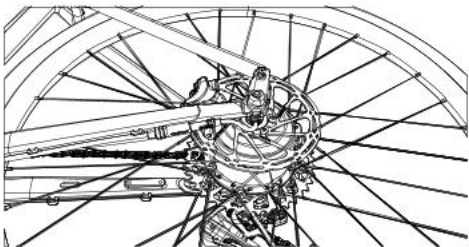

5.2.2 Free wheel and bottom bracket maintenance

The X30 system features a fully replaceable free wheel and bottom bracket that requires regular maintenance.

For both the free wheel and the bottom bracket there are detailed step-by-step instructions.

MAHLE manufactures the free wheel and the various bottom brackets and they are only compatible with the X30 system. The use of non-original spare parts voids the warranty and can lead to malfunctions that could result in serious injury or death.

Any replacement or maintenance should be carried out by a professional mechanic. Always check that cables or connectors are not damaged in the process of assembling or disassembling the system components.

Before making any replacements, read the recommendations of both MAHLE and the bicycle manufacturer, including all additional information on maintenance and care of the bicycle. Pay special attention to the instructions for disassembly and assembly of the bottom bracket.

5.2.3 Battery, engine and main unit

Batteries, especially internal batteries, should only be replaced or serviced by an authorised service centre.

We therefore recommend that you contact your dealer prior to replacement, as several items may require additional steps (such as battery activation) that can only be carried out by authorised MAHLE service technicians.

Please note that the MAHLE warranty does not cover the wheel assembly, only the X30 engine. If you have any problems with the spokes, rim or other parts of the rear wheel, please contact the manufacturer of your bicycle directly.



WARNING

Always confirm that both the engine side and the frame side of the automatic connector are clean before mounting the rear wheel. Check the connector before mounting the rear wheel: all pins must be straight. However, if you need help fitting the rear wheel, please contact your local dealer.



NOTICE

MAHLE SmartBike Systems elements require specific software activation. Pay special attention when replacing the bottom bracket, engine, battery or control unit. In any case, only professional mechanics should carry out such replacements.

5.3 Transporting your e-bike

Observe the region-specific regulations for the transport of your e-bike and external batteries to avoid possible damage during transport. Please refer to the applicable regulations or contact your local supplier.

5.4 Warranty

Warranty terms and periods are based on our final policy and the end-user warranty regulations and laws of each region. Please contact your distributor if you have any problems with the system, as MAHLE has established a global distribution and service network for the regions where the X30 system is authorised for sale.

5.5 Frequently Asked Questions Care and maintenance

I haven't used my SmartBike for a long time and now it doesn't turn on when I press the button.

If you haven't used the electric bike for more than 60 days, it has automatically gone into sleep mode. To activate, connect the charger. The battery may have gone into ultra-sleep mode, in which case you should leave it connected to the charger for at least one hour.

Can the internal battery be replaced?

Changing the battery also requires an additional process that only the dealer with the right tools can do, so they can only be changed in the official network.

Can a MAHLE display be installed in the SmartBike?

X30 Systems support the ANT+ LEV profile, so using the Pulsar ONE as a display is fully compatible with your X30.

Is it compatible with other displays?

You can find other compatible displays here: thisisant.com/directory/

Can the e-Bike electronic gears be installed or retrofitted?

It can technically be done, but the wiring of some OEM integrations could be complicated from the end-user's point of view.

By how much does the External Battery eX1 increase my range?

The External Battery eX1 gives you an extra 171 Wh. As with internal batteries, the increase in range depends on several factors such as the way the e-Bike is used, the environmental conditions, the rider's own conditions, etc. But it can be said that you could increase the range of the e-Bike by 50 % with iX3 batteries and 75 % with iX2 batteries.

Can the e-Bike battery be upgraded from the iX2 to the iX3?

Please consult your dealer, as changing the batteries will change the specifications of your e-Bike. However, although the two batteries share the same set points, they have different dimensions, so replacement will not be possible in some cases. Any replacement of the battery also requires the activation of the new battery by the dealer.

What do I have to do in the event of an incident in the system?

The main unit will display an error or warning. Connect to the MAHLE My SmartBike app to check the diagnostic code number that identifies the issue and share it with the authorised dealer or customer service.

Can the battery be repaired?

The battery is a dangerous object, which is why MAHLE recommends that it should only be handled by a MAHLE specialist and replaced with a new one from the MAHLE dealer network.

Can the system be updated?

Yes, visit our website for all the information on how to update your system:

<https://mahle-smartbike.com/firmware-update/>

Why does the main unit flash when the battery is about to run out?

The LED bar on the main unit will light up in the colour of the activated assistance level and will show the actual charge state of your battery. When the battery charge status is below 10 %, the LED bar on the main unit starts flashing to warn you of this status. On the other hand, when the state of charge is below 5 % the flashing is faster to warn you that the system may shut down at any time.

The X30 system is too powerful or not powerful enough, can I reduce or increase the power?

Of course. The X30 system includes the feature to adjust power, acceleration and reactivity. For a proper setting, install the My SmartBike APP, link your e-Bike and go to the engine settings. The custom setting gives you the opportunity to set your own power.

What is the range of the iX2 to iX3 batteries?

Range depends on weight and load carried, terrain elevation, wheel size, assistance used, defined engine configuration, speed and type of battery installed. This table can be used as a reference:

Internal Battery	Minimum Autonomy	Maximum Autonomy
iX2	40 km	100 km
iX3	60 km	140 km

Remember that you can always add an external battery eX1 which will almost double the internal battery of your iX2.

How long does it take to charge the internal battery?

80 % of the charge level can be obtained after the first 2 hours of charging, under standard conditions. The last part of the charging process will take longer depending on the version of the internal battery installed, but the maximum charging time is about 4 hours. 5 minutes after reaching the maximum charge level, the e-Bike switches off automatically.

My display or the main control unit shows an incident, what do I have to do?

The main unit will display an incident, so you will need to connect to the MAHLE My SmartBike app to check the diagnostic code number that identifies the type of issue and share it with the authorised dealer or customer service.

The control on the main unit flashes orange.

The functionality of the X30 is limited and therefore the main unit shows a warning signal. Connect to the MAHLE My SmartBike app to check the diagnostic code number that identifies the warning and share it with the authorised dealer or customer service.

The control on the main unit flashes red.

The functionality of the X30 is damaged and therefore the main unit shows an error signal. Connect to the MAHLE My SmartBike app to check the diagnostic code number that identifies the error and share it with the authorised dealer or customer service.

Can I use a third-party charger?

No. The charger is a device that communicates digitally with the batteries, and if you use non-genuine MAHLE equipment, you risk damaging the elements and breaching the terms of the warranty.

Can third-party External Battery eX1 be used?

No. The External Battery eX1, like the active charger, is a device that communicates digitally with the batteries, and if you use non-genuine MAHLE equipment, you risk damaging the elements and breaching the terms of the warranty.

What are the consequences of tampering with the e-Bike system?









Tampering with the system entails serious legal consequences. Tampering will cause a direct safety and security problem that will affect the normal designed mode of operation with a high risk of personal injury and loss of normal warranty terms. To avoid this, use only official MAHLE parts.













6. Diagnostic codes

The different diagnostic codes, the visual indication of the control unit and the actions to be taken in each situation are shown below. For more information, check with your local distributor or contact MAHLE's technical support:

 Flashing ORANGE (WARNING)

 Flashing RED (ERROR)

Code	HMI	Description / action
30		BATTERY Restart the bicycle. If the warning persists, take the bicycle to an authorised dealer.
32		CONTROL UNIT Restart the bicycle. If the warning persists, take the bicycle to an authorised dealer.
33		ENGINE SENSOR Restart the bicycle. If the warning persists, take the bicycle to an authorised dealer.
43		ENGINE SENSOR Restart the bicycle. If the warning persists, take the bicycle to an authorised dealer.
44		ENGINE CONTROL Charge the bicycle. If the warning persists, take the bicycle to an authorised dealer.
45		ENGINE CONTROL Discharge the bicycle. If the warning persists, take the bicycle to an authorised dealer.
46		ENGINE SENSOR Restart the bicycle. If the warning persists, take the bicycle to an authorised dealer.
47		ENGINE CONTROL HIGH TEMPERATURE Let the bike cool down by stopping or pedalling without assistance. If the warning persists, take the bicycle to an authorised dealer.
49		BATTERY Restart the bicycle. If the warning persists, update the system firmware to the latest available version. If the warning persists, take the bicycle to an authorised dealer.

50		BATTERY COMMUNICATION Restart the bicycle. If the warning persists, update the system firmware to the latest available version. If the warning persists, take the bicycle to an authorised dealer.
51		CONTROL UNIT Restart the bicycle. If the warning persists, update the system firmware to the latest available version. If the warning persists, take the bicycle to an authorised dealer.
52		ENGINE CONTROL Restart the bicycle. If the warning persists, take the bicycle to an authorised dealer.
53		ENGINE CONTROL HIGH TEMPERATURE Let the bike cool down by stopping or pedalling without assistance. If the warning persists, take the bicycle to an authorised dealer.
54		ENGINE CONTROL Restart the bicycle. If the warning persists, take the bicycle to an authorised dealer.
55		ENGINE CONTROL Restart the bicycle. If the warning persists, take the bicycle to an authorised dealer.
56		ENGINE SENSOR Restart the bicycle. If the warning persists, take the bicycle to an authorised dealer.
57		ENGINE SENSOR Restart the bicycle. If the warning persists, take the bicycle to an authorised dealer.
59		ENGINE SENSOR Restart the bicycle. If the warning persists, take the bicycle to an authorised dealer.
61		ENGINE Restart the bicycle. If the warning persists, take the bicycle to an authorised dealer.
62		ENGINE CONTROL Restart the bicycle. If the warning persists, update the system firmware to the latest available version. If the warning persists, take the bicycle to an authorised dealer.
67		CONTROL UNIT COMMUNICATION Restart the bicycle. If the warning persists, update the system firmware to the latest available version. If the warning persists, take the bicycle to an authorised dealer.

69		ENGINE Restart the bicycle. If the warning persists, take the bicycle to an authorised dealer.	133		CONTROL UNIT COMMUNICATION Restart the bicycle. If the warning persists, update the system firmware to the latest available version. If the warning persists, take the bicycle to an authorised dealer.
74		ENGINE Restart the bicycle. If the warning persists, take the bicycle to an authorised dealer.	134		CONTROL UNIT COMMUNICATION Restart the bicycle. If the warning persists, update the system firmware to the latest available version. If the warning persists, take the bicycle to an authorised dealer.
77		ENGINE Restart the bicycle. If the warning persists, take the bicycle to an authorised dealer.	135		CONTROL UNIT COMMUNICATION Check the External Battery eX1 connection. Restart the bicycle. Switch on the External Battery eX1. If the warning persists, take the bicycle to an authorised dealer.
80		ENGINE Restart the bicycle. If the warning persists, take the bicycle to an authorised dealer.	136		CONTROL UNIT Restart the bicycle. If the warning persists, update the system firmware to the latest available version. If the warning persists, take the bicycle to an authorised dealer.
81		CONTROL UNIT COMMUNICATION Restart the bicycle. If the warning persists, update the system firmware to the latest available version. If the warning persists, take the bicycle to an authorised dealer.	137		CONTROL UNIT Restart the bicycle. If the warning persists, update the system firmware to the latest available version. If the warning persists, take the bicycle to an authorised dealer.
84		ENGINE CONTROL Restart the bicycle. If the warning persists, take the bicycle to an authorised dealer.	138		CONTROL UNIT Restart the bicycle. If the warning persists, update the system firmware to the latest available version. If the warning persists, take the bicycle to an authorised dealer.
85		ENGINE CONTROL LOW TEMPERATURE Move the bicycle to a warmer place. If the warning persists, take the bicycle to an authorised dealer.	139		CONTROL UNIT Recalibrate the sensor using the APP. Restart the bicycle. Update the system firmware to the latest available version. If the warning persists, take the bicycle to an authorised dealer.
86		ENGINE CONTROL HIGH TEMPERATURE Let the bike cool down by stopping or pedalling without assistance. If the warning persists, take the bicycle to an authorised dealer.	140		CONTROL UNIT Restart the bicycle. If the warning persists, update the system firmware to the latest available version. If the warning persists, take the bicycle to an authorised dealer.
87		ENGINE SENSOR Restart the bicycle. If the warning persists, take the bicycle to an authorised dealer.	141		CONTROL UNIT COMMUNICATION Restart the bicycle. If the warning persists, update the system firmware to the latest available version. If the warning persists, take the bicycle to an authorised dealer.
129		CONTROL UNIT Take the bicycle to an authorised dealer.	132		CONTROL UNIT COMMUNICATION Restart the bicycle. If the warning persists, take the bicycle to an authorised dealer.
130		CONTROL UNIT Restart the bicycle. If the warning persists, update the system firmware to the latest available version. If the warning persists, take the bicycle to an authorised dealer.			
131		CONTROL UNIT Restart the bicycle. If the warning persists, update the system firmware to the latest available version. If the warning persists, take the bicycle to an authorised dealer.			

144		CONTROL UNIT Restart the bicycle. If the warning persists, update the system firmware to the latest available version. If the warning persists, take the bicycle to an authorised dealer.	184		BATTERY Charge the battery fully. If the warning persists, take the bicycle to an authorised dealer.
145		CONTROL UNIT Restart the bicycle. If the warning persists, update the system firmware to the latest available version. If the warning persists, take the bicycle to an authorised dealer.	185		HIGH BATTERY TEMPERATURE Let the bike cool down by stopping or pedalling without assistance. If the warning persists, take the bicycle to an authorised dealer.
160		CONTROL UNIT Restart the bicycle. If the warning persists, update the system firmware to the latest available version. If the warning persists, take the bicycle to an authorised dealer.	186		LOW BATTERY TEMPERATURE Place the bicycle in a warmer place. If the warning persists, take the bicycle to an authorised dealer.
167		BATTERY Charge the internal battery.	187		HIGH BATTERY TEMPERATURE DURING CHARGE Place the bicycle in a cool place and let it to cool down before charging. If the warning persists, take the bicycle to an authorised dealer.
168		BATTERY Charge the internal battery.	188		LOW BATTERY TEMPERATURE DURING CHARGE Place the bicycle in a warm place before charging. If the warning persists, take the bicycle to an authorised dealer.
169		HIGH BATTERY TEMPERATURE DURING CHARGE Let the bike to cool down before attempting charging again.	189		BATTERY Discharge the battery. If the warning persists, take the bicycle to an authorised dealer.
170		HIGH BATTERY TEMPERATURE Let the bike cool down by stopping or pedalling without assistance.	190		BATTERY Perform a full charge of the battery. If the warning persists, take the bicycle to an authorised dealer.
171		HIGH BATTERY TEMPERATURE Charge the internal battery	191		BATTERY Discharge the battery. If the warning persists, take the bicycle to an authorised dealer.
172		BATTERY If you have a device connected to the USB, disconnect it. Restart the bicycle. If the warning persists, take the bicycle to an authorised dealer.	192		BATTERY Perform a full charge of the battery. If the warning persists, take the bicycle to an authorised dealer.
173		BATTERY Restart the bicycle. If the warning persists, take the bicycle to an authorised dealer.	193		BATTERY Let the bike cool down by stopping or pedalling without assistance. If the warning persists, take the bicycle to an authorised dealer.
174		CONTROL UNIT Restart the bicycle. If the warning persists, take the bicycle to an authorised dealer.	194		CONTROL UNIT Take the bicycle to an authorised dealer.
180		BATTERY Restart the bicycle. If the warning persists, take the bicycle to an authorised dealer.	195		CONTROL UNIT Take the bicycle to an authorised dealer.
181		BATTERY Use a lower level of assistance. If the warning persists, take the bicycle to an authorised dealer.	196		ENGINE Restart the bicycle. If the warning persists, take the bicycle to an authorised dealer.
182		BATTERY Take the bicycle to an authorised dealer.	197		BATTERY Restart the bicycle. If the warning persists, take the bicycle to an authorised dealer.
183		BATTERY Take the bicycle to an authorised dealer.			

198		BATTERY COMMUNICATION Disconnect any device that is not a MAHLE original. Restart the bicycle. If the warning persists, take the bicycle to an authorised dealer.	228		LOW EXTERNAL BATTERY EX1 TEMPERATURE Place the external battery in a warmer environment. If the warning persists, take the external battery to an authorised dealer.
200		BATTERY COMMUNICATION Restart the bicycle. If the warning persists, take the bicycle to an authorised dealer.	229		EXTERNAL BATTERY EX1 Take the external battery to an authorised dealer.
201		BATTERY Restart the bicycle. If the warning persists, take the bicycle to an authorised dealer.	231		EXTERNAL BATTERY EX1 Unplug the charger and try using your e-Bike and the Range Extender. If the warning persists, take the external battery to an authorised dealer.
210		HIGH EXTERNAL BATTERY EX1 TEMPERATURE Lower the assist level, turn off the external battery or turn off the system completely. If the warning persists, take the external battery to an authorised dealer.	232		EXTERNAL BATTERY EX1 Charge the external battery. If the warning persists, take the external battery to an authorised dealer.
211		EXTERNAL BATTERY EX1 Charge the external battery. If the warning persists, contact an authorised dealer.	236		HIGH EXTERNAL BATTERY EX1 TEMPERATURE Place the external battery in a cooler environment. If the warning persists, take the external battery to an authorised dealer.
220		EXTERNAL BATTERY EX1 Take the external battery and its charger to an authorised dealer.	237		EXTERNAL BATTERY EX1 Take the external battery to an authorised dealer.
221		EXTERNAL BATTERY EX1 Disconnect the external battery. Check if the warning disappears. If the warning persists without an external battery, take the bicycle and external battery to an authorised dealer. If the warning does not persist without an external battery, take the bicycle to an authorised dealer.	238		EXTERNAL BATTERY EX1 Take the external battery to an authorised dealer.
222		EXTERNAL BATTERY EX1 Take the external battery to an authorised dealer.	248		HIGH CHARGER TEMPERATURE Allow the charger to cool down. If the warning persists, contact an authorised dealer.
224		EXTERNAL BATTERY EX1 Take the external battery to an authorised dealer.	249		CHARGER Contact an authorised dealer.
225		HIGH EXTERNAL BATTERY EX1 TEMPERATURE Place the external battery in a cooler environment. If the warning persists, take the external battery to an authorised dealer.	250		CHARGER Disconnect the charger from the mains. If the warning persists, contact an authorised dealer.
226		LOW EXTERNAL BATTERY EX1 TEMPERATURE Place the external battery in a warmer environment. If the warning persists, take the external battery to an authorised dealer.	251		CHARGER Disconnect the charger from the mains. If the warning persists, contact an authorised dealer.
227		HIGH EXTERNAL BATTERY EX1 TEMPERATURE Place the external battery in a cooler environment. If the warning persists, take the external battery to an authorised dealer.	252		CHARGER Disconnect any device that is not a MAHLE original. Restart the bicycle. If the warning persists, take the bicycle to an authorised dealer.
			253		CHARGER Disconnect any device that is not a MAHLE original. Restart the bicycle. If the warning persists, take the bicycle to an authorised dealer.

MAHLE SmartBike Systems S.L.U.
Los Orfebres 10
Palencia, Spain

mahle-smartbike.com