

# 2026 Salsa Fargo Apex S1000 AXS Transmission - Peat Moss - Geometrical Chart

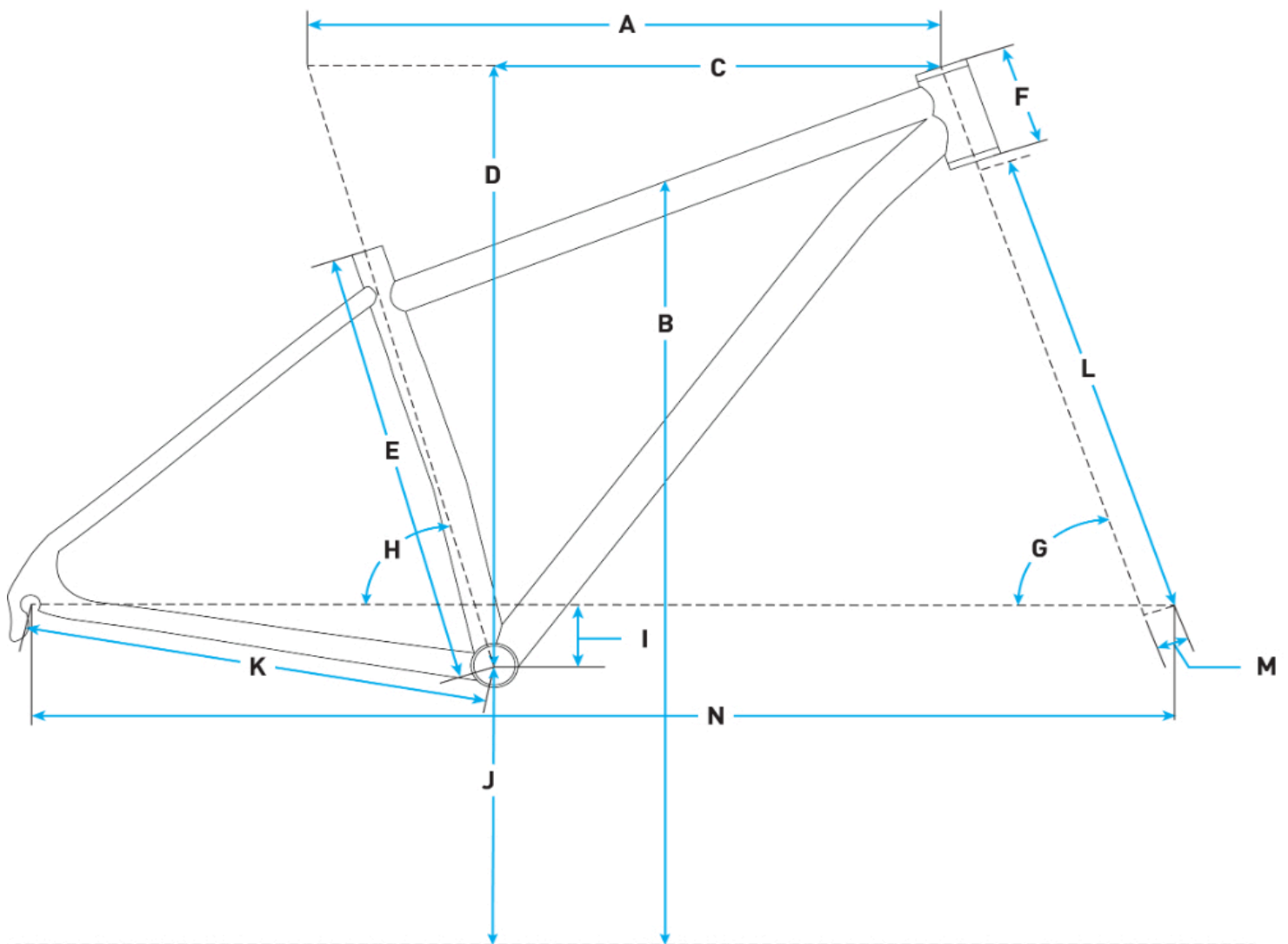

## Metric

| Size                             | X-Small | Small | Medium | Large | X-Large |
|----------------------------------|---------|-------|--------|-------|---------|
| <b>A. Effective Top Tube</b>     | 520.0   | 540.0 | 565.0  | 590.0 | 620.0   |
| <b>B. Stand Over</b>             | 690.0   | 732.0 | 778.0  | 821.0 | 859.0   |
| <b>C. Reach</b>                  | 352.0   | 366.0 | 371.0  | 388.0 | 412.0   |
| <b>D. Stack</b>                  | 584.0   | 605.0 | 633.0  | 661.0 | 680.0   |
| <b>E. Total Seat Tube Length</b> | 355.6   | 406.4 | 457.2  | 508.0 | 558.8   |
| <b>F. Headtube Length</b>        | 90.0    | 110.0 | 140.0  | 170.0 | 190.0   |
| <b>G. Headtube Angle</b>         | 68.5    | 69.0  | 69.0   | 69.0  | 69.0    |
| <b>H. Seat Tube Angle</b>        | 74.0    | 74.0  | 73.0   | 73.0  | 73.0    |
| <b>I. BB Drop</b>                | 70.0    | 70.0  | 70.0   | 70.0  | 70.0    |
| <b>J. BB Height</b>              | 303.0   | 303.0 | 303.0  | 303.0 | 303.0   |
| <b>K. Chainstay Length</b>       | 462.0   | 462.0 | 462.0  | 462.0 | 462.0   |

|                                     |               |               |               |               |               |
|-------------------------------------|---------------|---------------|---------------|---------------|---------------|
| <b>L. Fork Length Axle to Crown</b> | 483.0         | 483.0         | 483.0         | 483.0         | 483.0         |
| <b>M. Fork Offset</b>               | 51.0          | 51.0          | 51.0          | 51.0          | 51.0          |
| <b>N. Wheelbase</b>                 | 1067.0        | 1083.0        | 1099.0        | 1126.0        | 1158.0        |
| <b>Crank Arm Length</b>             | 165.0         | 165.0         | 170.0         | 170.0         | 175.0         |
| <b>Handlebar Width</b>              | 44.0          | 46.0          | 48.0          | 50.0          | 52.0          |
| <b>Recommended Rider Height</b>     | 147.0 - 160.0 | 157.0 - 170.0 | 168.0 - 180.0 | 178.0 - 191.0 | 188.0 - 201.0 |
| <b>Stem Length</b>                  | 60.0          | 70.0          | 70.0          | 80.0          | 80.0          |

## Imperial

| Size                                | X-Small       | Small         | Medium        | Large        | X-Large       |
|-------------------------------------|---------------|---------------|---------------|--------------|---------------|
| <b>A. Effective Top Tube</b>        | 20.47         | 21.26         | 22.24         | 23.23        | 24.41         |
| <b>B. Stand Over</b>                | 27.17         | 28.82         | 30.63         | 32.32        | 33.82         |
| <b>C. Reach</b>                     | 13.86         | 14.41         | 14.61         | 15.28        | 16.22         |
| <b>D. Stack</b>                     | 22.99         | 23.82         | 24.92         | 26.02        | 26.77         |
| <b>E. Total Seat Tube Length</b>    | 14            | 16            | 18            | 20           | 22            |
| <b>F. Headtube Length</b>           | 3.54          | 4.33          | 5.51          | 6.69         | 7.48          |
| <b>G. Headtube Angle</b>            | 68.5          | 69.0          | 69.0          | 69.0         | 69.0          |
| <b>H. Seat Tube Angle</b>           | 74.0          | 74.0          | 73.0          | 73.0         | 73.0          |
| <b>I. BB Drop</b>                   | 2.76          | 2.76          | 2.76          | 2.76         | 2.76          |
| <b>J. BB Height</b>                 | 11.93         | 11.93         | 11.93         | 11.93        | 11.93         |
| <b>K. Chainstay Length</b>          | 18.19         | 18.19         | 18.19         | 18.19        | 18.19         |
| <b>L. Fork Length Axle to Crown</b> | 19.02         | 19.02         | 19.02         | 19.02        | 19.02         |
| <b>M. Fork Offset</b>               | 2.01          | 2.01          | 2.01          | 2.01         | 2.01          |
| <b>N. Wheelbase</b>                 | 42.01         | 42.64         | 43.27         | 44.33        | 45.59         |
| <b>Crank Arm Length</b>             | 6.5           | 6.5           | 6.69          | 6.69         | 6.89          |
| <b>Handlebar Width</b>              | 173.23        | 181.1         | 188.98        | 196.85       | 204.72        |
| <b>Recommended Rider Height</b>     | 57.87 - 62.99 | 61.81 - 66.93 | 66.14 - 70.87 | 70.08 - 75.2 | 74.02 - 79.13 |
| <b>Stem Length</b>                  | 2.36          | 2.76          | 2.76          | 3.15         | 3.15          |

## Measurements based on:

- A Salsa Cutthroat Carbon Deluxe 483 x 51 mm offset fork
- A 29 x 2.4" tire measuring 746mm in diameter
- Standover (P) measured vertically to top of toptube from a position 50mm forward of BB center