

2026 Salsa Moraine Cues 10 - Black Coffee - Geometrical Chart

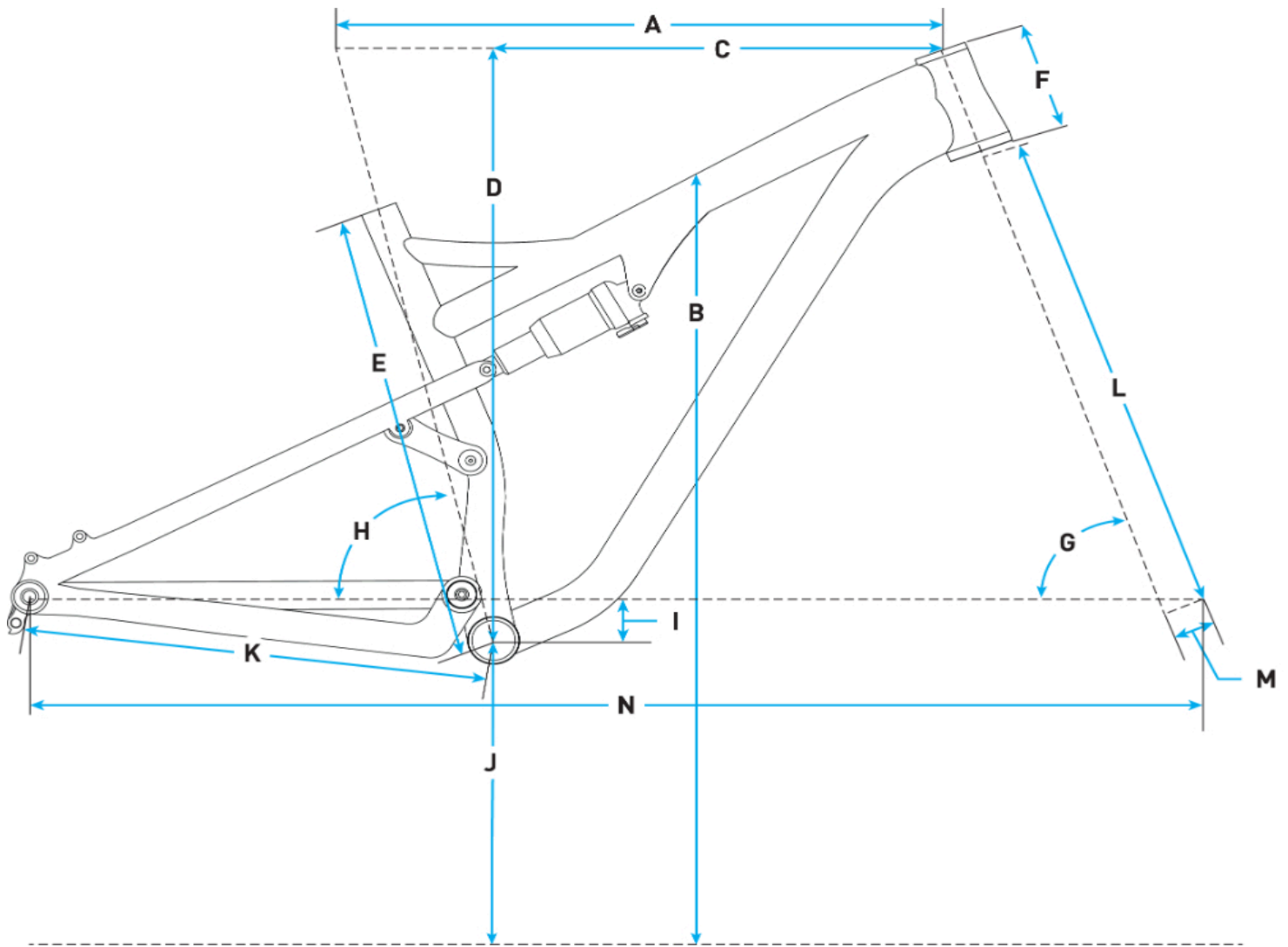

Metric

Size	Small	Medium	Large	X-Large
A. Effective Top Tube	590.2	612.2	634.2	656.2
B. Stand Over	754.6	754.5	754.3	754.2
C. Reach	453.0	473.0	493.0	513.0
D. Stack	613.6	622.6	631.6	640.5
E. Total Seat Tube Length	405.0	430.0	455.0	480.0
F. Headtube Length	100.0	110.0	120.0	130.0
G. Headtube Angle	63.9	63.9	63.9	63.9
H. Seat Tube Angle	77.4	77.4	77.4	77.4
I. BB Drop	25.0	25.0	25.0	25.0
J. BB Height	351.0	351.0	351.0	351.0
K. Chainstay Length	435.3	435.3	435.3	435.3
L. Fork Length Axle to Crown	573.0	573.0	573.0	573.0
M. Fork Offset	44.0	44.0	44.0	44.0

N. Wheelbase	1225.0	1249.4	1273.8	1298.2
Crank Arm Length	165.0	165.0	165.0	165.0
Handlebar Width	780.0	780.0	780.0	780.0
Recommended Rider Height	157.0 - 170.0	168.0 - 180.0	178.0 - 191.0	188.0
Stem Length	40.0	40.0	40.0	40.0

Imperial

Size	Small	Medium	Large	X-Large
A. Effective Top Tube	23.24	24.1	24.97	25.83
B. Stand Over	29.71	29.7	29.7	29.69
C. Reach	17.83	18.62	19.41	20.2
D. Stack	24.16	24.51	24.87	25.22
E. Total Seat Tube Length	15.94	16.93	17.91	18.9
F. Headtube Length	3.94	4.33	4.72	5.12
G. Headtube Angle	63.9	63.9	63.9	63.9
H. Seat Tube Angle	77.4	77.4	77.4	77.4
I. BB Drop	0.98	0.98	0.98	0.98
J. BB Height	13.82	13.82	13.82	13.82
K. Chainstay Length	17.14	17.14	17.14	17.14
L. Fork Length Axle to Crown	22.56	22.56	22.56	22.56
M. Fork Offset	1.73	1.73	1.73	1.73
N. Wheelbase	48.23	49.19	50.15	51.11
Crank Arm Length	6.5	6.5	6.5	6.5
Handlebar Width	780.0	780.0	780.0	780.0
Recommended Rider Height	61.81 - 66.93	66.14 - 70.87	70.08 - 75.2	74.02
Stem Length	1.57	1.57	1.57	1.57

Measurements based on:

- An unsprung bike (no sag)
- A 29 x 2.5" tire measuring 752 mm in diameter
- Standover (D) for all sizes is measured vertically to top of toptube from a position 50mm forward of BB center