

2026 Salsa Tributary C Rival GX AXS SUS - Charcoal/Black - Geometrical Chart

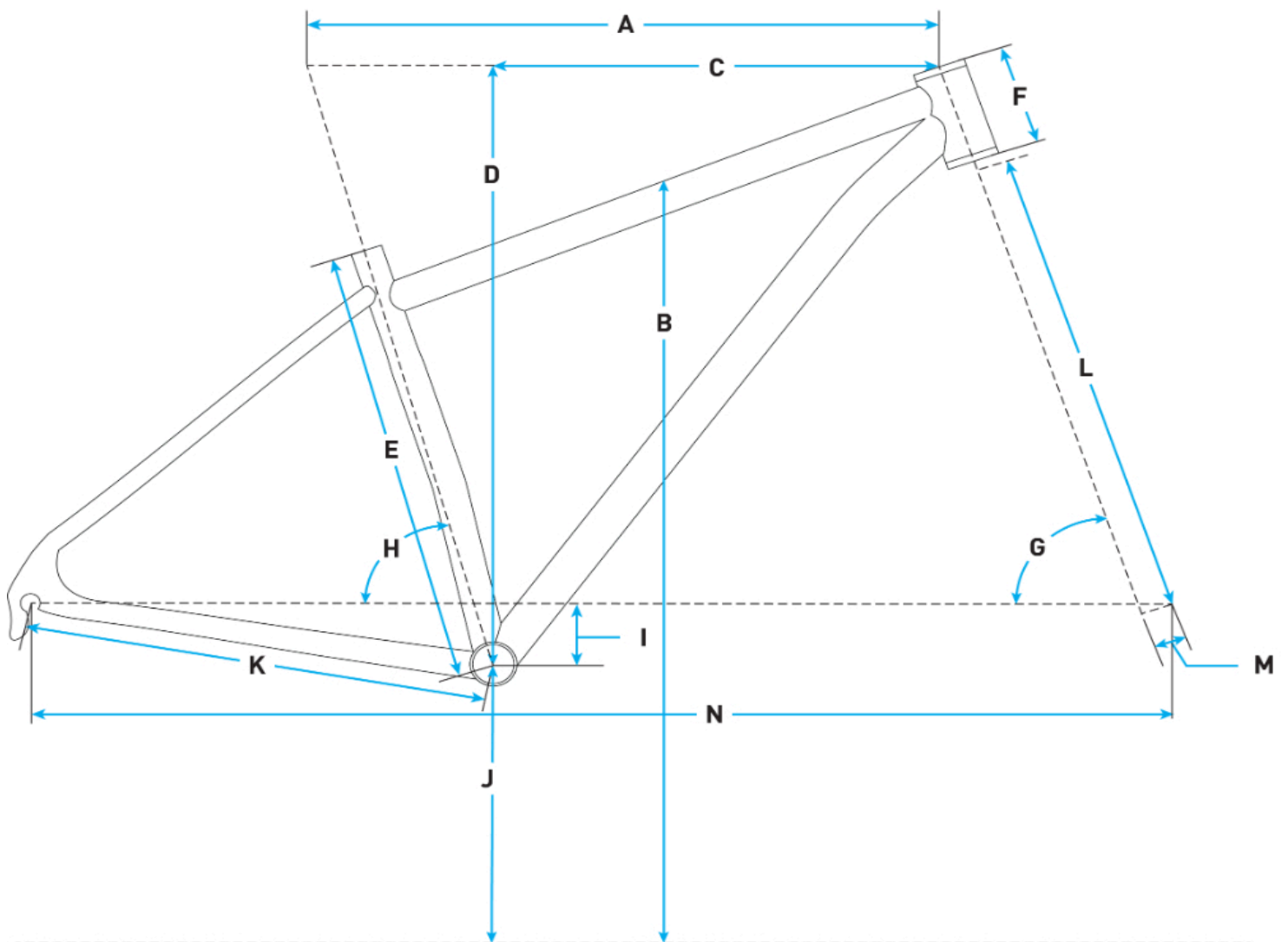

Metric

Size	X-Small	Small	Medium	Large	X-Large
A. Effective Top Tube	535.0	560.0	585.0	610.0	635.0
B. Stand Over	725.1	729.7	775.0	808.9	827.4
C. Reach	373.7	398.7	417.6	437.6	457.7
D. Stack	601.8	601.8	624.8	643.2	661.7
E. Total Seat Tube Length	380.0	405.0	460.0	500.0	520.0
F. Headtube Length	100.0	100.0	125.0	145.0	165.0
G. Headtube Angle	67.0	67.0	67.0	67.0	67.0
H. Seat Tube Angle	75.0	75.0	75.0	75.0	75.0
I. BB Drop	70.0	70.0	70.0	70.0	70.0
J. BB Height	303.0	303.0	303.0	303.0	303.0
K. Chainstay Length	445.0	445.0	445.0	445.0	445.0

L. Fork Length Axle to Crown	498.4	498.4	498.4	498.4	498.4
M. Fork Offset	51.0	51.0	51.0	51.0	51.0
N. Wheelbase	1094.4	1119.4	1148.0	1175.8	1203.7
Crank Arm Length	165.0	165.0	170.0	170.0	170.0
Handlebar Width	44.0	46.0	48.0	50.0	52.0
Recommended Rider Height	155.0 - 163.0	163.0 - 170.0	170.0 - 178.0	178.0 - 185.0	185.0 - 193.0
Stem Length	50.0	50.0	50.0	50.0	50.0

Imperial

Size	X-Small	Small	Medium	Large	X-Large
A. Effective Top Tube	21.06	22.05	23.03	24.02	25
B. Stand Over	28.55	28.73	30.51	31.85	32.57
C. Reach	14.71	15.7	16.44	17.23	18.02
D. Stack	23.69	23.69	24.6	25.32	26.05
E. Total Seat Tube Length	14.96	15.94	18.11	19.69	20.47
F. Headtube Length	3.94	3.94	4.92	5.71	6.5
G. Headtube Angle	67.0	67.0	67.0	67.0	67.0
H. Seat Tube Angle	75.0	75.0	75.0	75.0	75.0
I. BB Drop	2.76	2.76	2.76	2.76	2.76
J. BB Height	11.93	11.93	11.93	11.93	11.93
K. Chainstay Length	17.52	17.52	17.52	17.52	17.52
L. Fork Length Axle to Crown	19.62	19.62	19.62	19.62	19.62
M. Fork Offset	2.01	2.01	2.01	2.01	2.01
N. Wheelbase	43.09	44.07	45.2	46.29	47.39
Crank Arm Length	6.5	6.5	6.69	6.69	6.69
Handlebar Width	173.23	181.1	188.98	196.85	204.72
Recommended Rider Height	61.02 - 64.17	64.17 - 66.93	66.93 - 70.08	70.08 - 72.83	72.83 - 75.98
Stem Length	1.97	1.97	1.97	1.97	1.97

Measurements based on:

- An unsprung bike (no sag)
- A 29 x 2.3" tire measuring 747 mm in diameter
- Standover (B) for all sizes is measured vertically to top of toptube from a position