

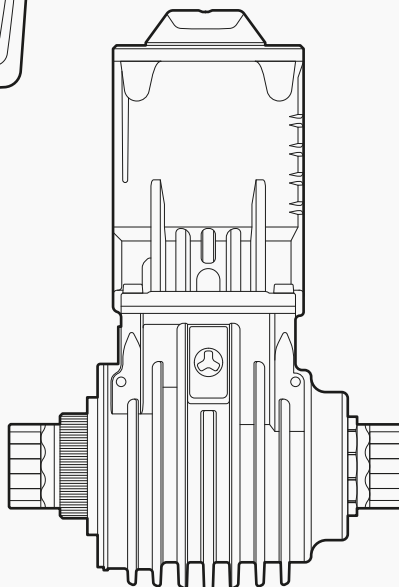

# FAZUA *RIDE 60 DRIVE SYSTEM*

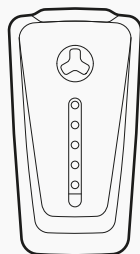

**FAZUA**

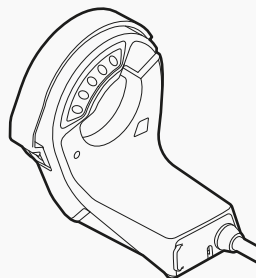
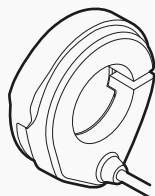
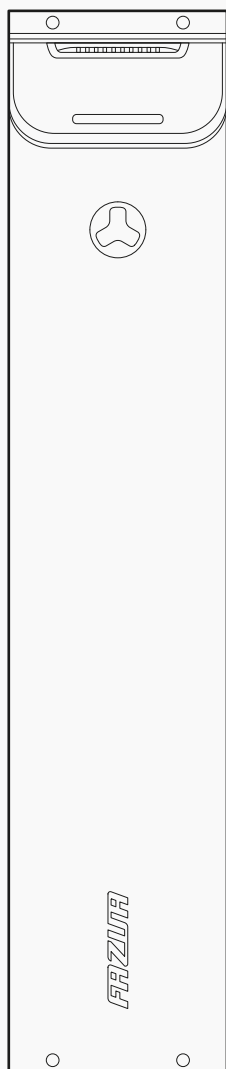

## GENERAL INFORMATION

<b>1</b>	<b>ABOUT THESE INSTRUCTIONS</b> .....	<b>6</b>
1.1	Read and keep the instructions.....	6
1.2	Description of signs and symbols.....	6
<b>2</b>	<b>SAFETY</b> .....	<b>7</b>
2.1	Functionality & intended use .....	7
2.2	Limitation of liability .....	8
2.3	Symbols & pictograms of the drive system.....	8
2.4	Important safety instructions .....	10
2.5	Notes on safe riding in road traffic .....	12
<b>3</b>	<b>INSTRUCTIONS FOR RIDING a E-BIKE WITH THE FAZUA DRIVE SYSTEM</b> .....	<b>12</b>
<b>4</b>	<b>STORAGE AND TRANSPORT OF E-BIKES WITH THE FAZUA DRIVE SYSTEM</b> .....	<b>14</b>
<b>5</b>	<b>FAZUA APP</b> .....	<b>15</b>
<b>6</b>	<b>PERFORMING a FIRMWARE UPDATE</b> .....	<b>15</b>
<b>7</b>	<b>TROUBLESHOOTING</b> .....	<b>16</b>
<b>8</b>	<b>DISPOSAL INFORMATION</b> .....	<b>17</b>
8.1	Disposal of your e-bike .....	17
8.2	Battery disposal .....	18
<b>9</b>	<b>CONSUMER WARRANTY IN THE UNITED STATES</b> .....	<b>18</b>
<b>10</b>	<b>SERVICE</b> .....	<b>19</b>
<b>11</b>	<b>CONFORMITY</b> .....	<b>20</b>

## DRIVE UNIT

<b>12</b>	<b>FUNCTIONALITY AND MODEL VARIANTS OF THE DRIVE UNIT</b> .....	<b>21</b>
<b>13</b>	<b>ILLUSTRATIONS FOR THE DRIVE UNIT</b> .....	<b>21</b>
13.1	Detail view and part designations/positions on the e-bike.....	21
<b>14</b>	<b>TECHNICAL DATA ON THE DRIVE UNIT</b> .....	<b>22</b>
<b>15</b>	<b>CORRECT POSITION OF SPEED SENSOR AND MAGNET</b> .....	<b>22</b>
<b>16</b>	<b>CLEANING AND MAINTAINING THE DRIVE UNIT</b> .....	<b>23</b>

## **CONTROL ELEMENT AND DISPLAY**

<b>17</b>	<b>FUNCTIONALITY AND MODEL VARIANTS OF THE CONTROL ELEMENT AND DISPLAY</b> .....	<b>24</b>
<b>18</b>	<b>CONTROL ELEMENT AND DISPLAY ILLUSTRATIONS</b> .....	<b>24</b>
18.1	Detailed view and part designations .....	24
18.2	Positions on the e-bike .....	25
<b>19</b>	<b>TECHNICAL DATA FOR THE CONTROL ELEMENT AND DISPLAY</b> .....	<b>26</b>
<b>20</b>	<b>DRIVING AND STATUS INFORMATION ON THE DISPLAY</b> .....	<b>26</b>
20.1	E-bike status .....	26
20.2	Current charge level and set support level .....	27
<b>21</b>	<b>USING THE CONTROL ELEMENT</b> .....	<b>28</b>
21.1	Switching the drive system on and off .....	28
21.2	Setting the pedal support .....	29
21.3	Levels of support .....	29
21.4	Boost function .....	30
21.5	"Push Assist" mode .....	31
21.5.1	General information about the mode .....	31
21.5.2	Using "Push Assist" mode .....	32
21.6	Switching the bicycle lighting on and off .....	32
21.7	Bluetooth® connection .....	32
<b>22</b>	<b>CLEANING AND MAINTAINING THE CONTROL ELEMENT AND DISPLAY</b> .....	<b>33</b>

## **BATTERY AND CHARGER**

<b>23</b>	<b>FUNCTION AND MODEL VARIANTS OF THE BATTERY</b> .....	<b>34</b>
<b>24</b>	<b>BATTERY AND CHARGER ILLUSTRATIONS</b> .....	<b>34</b>
24.1	Detailed view and part designations .....	34
24.2	Position on e-bike .....	35
<b>25</b>	<b>TECHNICAL DATA FOR BATTERY AND CHARGER</b> .....	<b>36</b>
25.1	Technical data on the battery .....	36
25.2	Technical data on the charger .....	36
<b>26</b>	<b>GENERAL SAFETY INSTRUCTIONS FOR THE BATTERY AND CHARGER</b> .....	<b>36</b>

<b>27 USING THE BATTERY .....</b>	<b>40</b>
27.1 Inserting the battery on the e-bike/removing it from the e-bike .....	40
27.1.1 Inserting the battery .....	40
27.1.2 Removing the battery .....	41
27.2 Checking the charge level and SOH of the battery .....	42
<b>28 CHARGING THE BATTERY .....</b>	<b>43</b>
28.1 Prepare charger.....	43
28.2 Connecting the charger .....	44
28.2.1 Charging the (integrated) battery in the e-bike .....	44
28.2.2 Charging the battery separately .....	44
28.3 Charging process.....	44
28.4 Unplug charger from battery .....	45
<b>29 CLEANING THE BATTERY AND CHARGER.....</b>	<b>45</b>
29.1 Cleaning the battery .....	46
29.2 Cleaning the charger .....	46

# 1 ABOUT THESE INSTRUCTIONS

## 1.1 Read and keep the instructions

These original instructions\* are part of the scope of supply of the FAZUA RIDE 60 drive system. They contain all important information on the safety and use of the individual components and the drive system as a whole. These instructions are based on the laws applicable in the United States, as well as national regulations such as UL® and ANSI testing standards.

Be sure to read the complete instructions carefully before using the components or the drive system installed in your e-bike for the first time. Failure to follow the instructions could result in serious injury to you or others and/or damage to the drive system or individual components.

Always keep these instructions handy for further use and pass them on if you pass on the drive system or the equipped e-bike to third parties.

In addition to these instructions for the drive system, always observe the manufacturer's instructions for the e-bike in which the drive system is installed.

The Bluetooth® word mark and logos are registered trademarks of Bluetooth SIG, Inc. and are used by FAZUA under license.

These instructions may not be reproduced, modified, distributed or used in any way, in whole or in part, without prior written permission.

## 1.2 Description of signs and symbols

Certain types of notes and information in these instructions are identified by signs or symbols, which are listed below together with their meaning.

### DANGER

High risk level! Risks that result in death or serious injury are indicated by the signal word "Danger".

### WARNING

Risks that could result in death or serious injury are marked with the signal word "Warning".

### CAUTION

Risks that could result in moderate or minor injuries are indicated by the signal word "Caution".

\* These "original instructions" will be referred to as "instructions" in the further course.

## NOTE

Risks relating to damage to the product itself or to property damage to other objects are indicated by the signal word "Notice".



Useful additional information is marked with this information symbol.

## 2 SAFETY

### 2.1 Functionality & intended use

FAZUA drive systems are designed as electric drive systems for e-bikes used as a means of transport. As intended, the electric pedal assist switches off as soon as you reach or exceed a certain [country and product specific] speed\*. When you ride at a speed that exceeds the switch-off point, you pedal without assistance from the motor, using only your own muscle power.

The drive system as a whole consists of several components:

**A** → **Drive unit**

→ You can find detailed information here in section "Drive unit"

**B** → **Remote**

→ You can find detailed information here in section "Control element and display"

**C** → **Battery and charger**

→ You can find detailed information here in section "Battery and charger"

The individual components are available in different model versions, which partly differ from each other due to their design and handling. Detailed information on the function of the individual components as part of the drive system, as well as on special features and handling of the specific models can be found in the component sections of these instructions.

The version of the drive system installed in your e-bike, i.e. the specific combination of component models, is specially adapted to your e-bike and must therefore not be changed.

Categorically, the installation of the drive system and certain work on it may only be carried out in the ways planned by the manufacturer or by an authorized specialist. Authorized specialists for repair and maintenance work can be found with the official FAZUA service partners (See Chapter 10 "Service").

\* In the United States, the speed at which the electric pedal assist automatically switches off is 20 mph (32 km/h).

For information on which work you can carry out yourself and which work must be carried out by an authorized specialist, refer to the sections on the individual components of this manual.

## 2.2 Limitation of liability

FAZUA accepts no liability for damage caused by incorrect or improper installation or use other than that intended. Only use the components of the drive system as described in this manual. Any other use is considered improper and may result in accidents, serious injury and damage to the drive system.

## 2.3 Symbols & pictograms of the drive system

On individual components of the drive system you will find certain symbols and pictograms, which are listed below including their meaning.



This symbol indicates that the user of the drive system or the individual components must have read and understood this original instructions before using it.

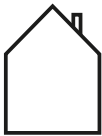

A device marked with this symbol (here: the charger) may only be used in dry indoor areas.

 **DANGER**

When used in a humid environment and in contact with liquids, there is a risk of electric shock!



An electrical appliance marked with this symbol corresponds to protection class II: The device has double or reinforced insulation to protect against electric shock.



This symbol warns of hot surfaces.

 **DANGER**

There is a burning risk if touched, contact with combustible materials may cause a fire.



These symbols indicate that the battery (lithium-ion battery) must be disposed of separately at the end of its service life and may not be disposed of with household waste.



Li-ion

The symbols must be affixed in the European Union in accordance with the laws and directives in force there.



This symbol indicates that the marked component must be disposed of separately as electrical or electronic equipment at the end of its service life and may not be disposed of with household waste.

The symbol must be affixed in the European Union in accordance with the laws and directives in force there.



This symbol indicates products that meet all the requirements for obtaining the European CE marking.



This symbol identifies products that meet all requirements for obtaining the British UKCA marking.



The test seal "Geprüfte Sicherheit" (GS mark) is awarded by independent certification bodies.

A device marked with the GS test seal complies with the safety-relevant requirements of the German Product Safety Act (ProdSG).



The "UL®-Listed" seal of approval is awarded by the US UL® Certification Body.

A device marked with the "UL®-Listed" test seal shown corresponds to the safety-relevant requirements for Canada and the USA.



The accompanying test seal is awarded by the SGS certification body.

A device marked with this test seal complies with the safety-relevant requirements for Canada and the United States in accordance with UL Standards.

The drive system and the battery were tested according to UL Standards. The following UL Standards were applied: UL 2271 - Standard for Batteries for Use in Light Electric Vehicle (LEV) Applications, UL 2849 - Outline of Investigation for Electric Bicycles, Electrically Power Assisted Cycles (EPAC Bicycles), Electric Scooters, and Electric Motorcycles.



The FCC seal is awarded by the Federal Communications Commission, an independent U.S. government agency responsible for implementing and enforcing U.S. communications laws and regulations.

An electrical device marked with the FCC seal complies with American standards for electromagnetic compatibility.

## 2.4 Important safety instructions

# **READ AND KEEP ALL IMPORTANT SAFETY INSTRUCTIONS!**

The general safety instructions listed below refer to the drive system as a whole and must always be taken into account when using the e-bike equipped with it.

### **DANGER**

#### **Dangers for users of e-bikes!**

Basically there are specific dangers for the users of e-bikes. Depending on the e-bike model in which the drive system is installed, additional dangers may arise which are not mentioned here.

- ▶ Read and follow the manufacturer's instructions for your e-bike.
- ▶ Find out about and observe any applicable national regulations regarding e-bikes.

### **DANGER**

#### **Dangers due to unauthorized changes!**

If you make unauthorized changes to the drive system or components, you may cause an explosion, electric shock, or serious injury to yourself or others.

- ▶ Under no circumstances should you modify or alter individual components of the drive system autonomously.
- ▶ Never replace any drive system components independently.
- ▶ Never open the drive system components without authorization. The drive system components do not require any maintenance.
- ▶ Only allow repairs to the drive system to be carried out by an authorized specialist.
- ▶ Only allow components of the drive system to be replaced by an authorized specialist with permissible original spare parts.

### **DANGER**

#### **Risk of electric shock and fire if handled incorrectly!**

If you handle the battery and/or charger improperly or use incompatible

batteries and chargers together, they may cause a fire. The battery may explode if handled incorrectly.

- ▶ Only use the battery in e-bikes equipped with an original FAZUA RIDE 60 drive system. Never use the battery for other purposes or in other drive systems.
- ▶ Follow all charging instructions and do not charge the battery pack (battery) outside of the temperature range specified in the instructions. Charging improperly or at temperatures outside of the specified range may damage the battery and increase the risk of fire.
- ▶ Do not modify or attempt to repair the charger or the battery pack.

### **WARNING**

**Danger from accidental starting!**

Starting the drive system in unsuitable situations can result in accidents and serious injury.

- ▶ To prevent the drive system from starting up, switch off the drive system and, if necessary, secure it against being switched back on unintentionally or unnoticed when the e-bike is being transported or stored and during all work on the e-bike.
- ▶ If possible, remove the battery.\*

### **NOTE**

**Risk of damage!**

Improper handling can damage the drive system or individual components.

- ▶ Only have individual components of the drive system replaced with components of identical design or other components expressly approved by the manufacturer of the drive system. This will protect the other components from possible damage.
- ▶ Have individual components of the e-bike replaced exclusively by identical components or other components expressly approved by the e-bike manufacturer. This will protect your e-bike (incl. drive system) from possible damage.

\* This applies only if your e-bike is equipped with a removable battery (See Chapter 23 "Function and model variants of the battery").

## 2.5 Notes on safe riding in road traffic

By following the road safety precautions listed below, you can reduce the risk of accidents and injuries when riding a bicycle or e-bike in road traffic.



The term "road traffic" also refers to private areas open to the public and to field or forest paths open to the public.

- Only ride your e-bike on the road if the equipment complies with national road traffic regulations. Please contact your e-bike manufacturer for more information.
- Find out about the regulations applicable to road traffic in your country or region, e.g. from the Ministry of Transport. You should also keep yourself informed about any changes to the contents of the valid regulations.
- Observe and follow national and regional road traffic regulations.
- When riding, use a suitable bicycle helmet that complies with national and regional regulations (CPSC (Consumer Product Safety Commission, 16 CFR Part 1203 or ASTM F1447-06).
- When riding, wear light-colored clothing with reflective elements to attract the attention of other road users.
- Do not ride your e-bike if you are under the influence of alcohol, narcotics or medications.
- Do not use mobile devices such as smartphones, MP3 players, etc. while riding.
- Do not distract yourself while riding by other activities such as switching on the light. Stop to carry out such activities.
- Never ride without your hands, under any circumstances. Always keep both hands on the handlebars.
- Ride carefully and be considerate of other road users.
- Ride in such a way that nobody is harmed, endangered, obstructed or annoyed.
- Ride on prescribed lanes for bicycles.

## 3 INSTRUCTIONS FOR RIDING a E-BIKE WITH THE FAZUA DRIVE SYSTEM

Observe the following instructions for riding your e-bike equipped with the FAZUA drive system.

### Gear change:

The gearshift of your e-bike can be operated in the same way as that of a conventional bicycle. Selecting a suitable gear increases the speed, power and range of your e-bike while maintaining pedal frequency.

Irrespective of the type of gearshift mounted, the following applies:

→ Stop pedaling when you change gears. This relieves the load on the rear derailleur and the drive of your e-bike.

### **Range/trip planning:**

How long or how far you can ride your e-bike before you need to recharge the battery depends on several factors.

These factors include, but are not limited to:

- the set assistance level;
- the (riding) speed with which you move;
- your gear changing;
- the type of tire and the tire pressure set;
- the selected route and the weather conditions;
- the weight of driver and e-bike (total weight);
- the condition and age of the battery.

The following therefore applies as a matter of principle:

- Familiarize yourself with your e-bike step by step and away from roads and heavy traffic.
- Test the maximum range of your e-bike under various external conditions before planning longer trips. An exact statement about the range of your system is neither possible before nor during a trip.

### **Storage and operating temperatures**

- Observe the operating and storage temperatures for the components of the drive system and for the components of your e-bike - especially for the battery, as it can be damaged by extreme temperatures.
- For more detailed information on operating and storage temperatures, refer to the technical data of the individual components on Page 22, Page 26 and Page 36, as well as in Chapter 4 "Storage and transport of e-bikes with the FAZUA drive system".



If you do not handle the battery properly, it may explode!

## 4 STORAGE AND TRANSPORT OF E-BIKES WITH THE FAZUA DRIVE SYSTEM

### WARNING

#### Danger from accidental starting!

Starting the drive system in unsuitable situations can result in accidents and serious injury.

- ▶ To prevent the drive system from starting up, switch off the drive system and, if necessary, secure it against being switched back on unintentionally or unnoticed when the e-bike is being transported or stored.
- ▶ If possible, remove the battery.\*

- When transporting and storing your e-bike or the components of the drive system, observe the specified temperature ranges for the components.
- If your e-bike has a removable battery, always transport and store the battery separately from the e-bike.

Batteries are subject to the dangerous goods regulations. Undamaged batteries may be transported by private individuals in road traffic. Commercial transport requires compliance with the rules on the packaging, labeling and transport of dangerous goods. Open contacts must be covered and the battery securely packed. When sending, the parcel service must be informed of the presence of dangerous goods in the packaging.

- Please note the following information on the charge level of the battery during prolonged non-use and the information on the temperature ranges for the corresponding storage periods.

If you do not intend to use the battery for an extended period of time, it should have a minimum charge level of 60% before you stop using it.

Check the charge status of the battery after 6 months of non-use: If the check reveals that the charge level is 20% or less, recharge the battery to a charge level of 60% or more.

Consider the following storage time-dependent temperature ranges for the battery (charge level 60 %):

- < 1 month storage time: 5 to 140 °F (-15 to 60 °C)
- 3 months storage time: 5 to 113 °F (-15 to 45 °C)
- 1 year storage time: 5 to 70 °F (-15 to 25 °C)

\* This applies only if your e-bike is equipped with a removable battery (See Chapter 23 "Function and model variants of the battery").

→ If you have further questions, please contact a FAZUA Certified Partner or visit the official FAZUA service platform (<https://fazua.com/de/support>).

## 5 **FAZUA APP**

Your control element is equipped with a Bluetooth® function. As a result, you can connect a mobile device to the remote and utilize other features using the FAZUA app. You can download the FAZUA app from the FAZUA homepage, which provides detailed information about the FAZUA app and its functions. You can access the corresponding website directly by scanning the following QR code:



[fazua.com/energy/app-connectivity](https://fazua.com/energy/app-connectivity)

## 6 **PERFORMING a FIRMWARE UPDATE**



To update the firmware, connect the drive system to your computer. You will need a USB cable for this purpose\*.

Depending on the model, the USB socket for connection is located on the control element or on the separate display (see chapter 18 “Control element and display illustrations” | 18.2 “Positions on the e-bike”).

Visit the FAZUA homepage for a detailed description of how to perform the firmware update. You can access the corresponding website directly by scanning the following QR code:



[fazua.com/firmware](https://fazua.com/firmware)

---

\* The USB cable is not supplied.

## 7 TROUBLESHOOTING

1. If your e-bike or drive system does not function as desired, first check whether the fault can be rectified using the "Troubleshooting" overview table below.
2. If necessary, contact a FAZUA Certified Partner or visit the FAZUA service platform (<https://fazua.com/de/support>), if:
  - the error is not listed in the overview table,
  - the error is listed in the overview table, but it cannot be corrected in the way described here or you are unsure.

<b>TROUBLESHOOTING" OVERVIEW TABLE</b>	
<b>Problem</b>	<b>possible Reason / Solution</b>
The engine feels weaker than usual.	The drive system is brand new. → Wait until the drive system is "run in". The drive system needs a few miles to develop its full power
	It is very hot and the heat management of the battery and/or drive unit limits the performance.
	It is very cold and the battery (=lithium-ion battery) does not deliver the usual performance.
The upper LED on the control element/ display lights up/flashes red.	There is a connection error between the drive unit and battery. Dirt on the connectors or jammed cables may be preventing the connection. → Clean the connectors to be able to insert the battery properly.*
The upper LED on the control element/ display lights up/flashes yellow.	There may be a bad connection between the speed sensor and the bottom bracket. → Check that the speed sensor and magnet are correctly located in their receptacle on the rear wheel. If you cannot find any faults, contact a FAZUA Certified Partner.
The white LEDs of the control element/ display flash.	Software update → After a new firmware update, the control element is updated automatically. In this case, please wait and do not switch off the control element until the LEDs stop flashing

\* This applies only if your e-bike is equipped with a removable battery (See Chapter 23 "Function and model variants of the battery").

<b>TRUBLESHOOTING" OVERVIEW TABLE</b>	
<b>Problem</b>	<b>possible Reason / Solution</b>
The control element/ display cannot be switched on.	The battery is flat or has switched off due to a longer rest period (standstill). → Try turning on the battery using the on/off button. → Charge the battery if necessary.
	The interface between the battery and the drive unit may be dirty. → Clean the interface between the battery and the drive unit.*
The battery cannot be inserted or does not engage in the battery holder.	The interface between the battery and the drive unit may be dirty. / It is possible that the engagement of the battery is obstructed by a cable, hydraulic line or Bowden cable. → Clean the interface between the battery and the drive unit. → Make sure that no cable prevents the battery from engaging.
The pedal support suddenly fails during the ride.	BMS protection function → Shut down the drive system by pressing and holding the control switch down for 8 seconds. When the drive system is ready to be switched on again, the status indicator LED flashes green: Now you can restart your drive system as usual.

## **8 DISPOSAL INFORMATION**

According to the EU Directives for waste electrical and electronic equipment (Directive 2012/19/EU) and spent batteries (Directive 2006/66/EC), the relevant components must be collected separately and disposed of in an environmentally sound manner.

→ Before disposing of your e-bike, remove the battery and any other batteries installed on the e-bike as well as all components and controls that contain batteries.

### **8.1 Disposal of your e-bike**

After you have removed all batteries, the e-bike is considered an old electrical appliance and must be recycled.

\* This applies only if your e-bike is equipped with a removable battery (See Chapter 23 "Function and model variants of the battery").

- Find out from your city or municipal administration (municipality, district) about free collection points for old electrical appliances and/or collection points, via which the components or the e-bike can be recycled.
- When disposing of the product, observe the requirements of the United States Environmental Protection Agency ([www.epa.gov](http://www.epa.gov)).
- If necessary, make sure to delete any personal data stored on the device before you return the electrical or electronic equipment to the collection point. This task is your responsibility.

## **8.2 Battery disposal**

The drive system battery is a lithium-ion battery that must be disposed of as hazardous waste.

- Dispose of the battery of the drive system and any other batteries installed in the e-bike at a recycling center or a collection point in your town or municipality.
- If required, visit the website of call2recycle: [www.call2recycle.org](http://www.call2recycle.org). You will find extensive content here on the subject of "Recycling batteries", as well as a search function for collection points in your area.

## **9 CONSUMER WARRANTY IN THE UNITED STATES**

FAZUA GmbH, warrants to the end customer (hereinafter referred to as "customer"), in accordance with the provisions set forth below, that the drive system integrated in the bicycle purchased by the customer, including the components of the drive system, (hereinafter collectively referred to as "product") will remain free of construction, material and manufacturing defects and be fully functional for a period of two years following delivery to you (warranty period).

However, in the event that a defect should occur, or if the drive system does not remain fully functional, the FAZUA GmbH shall, at its own discretion, remedy the defect(s) at its own expense by either performing repairs or providing new or refurbished parts.

However, claims under this warranty shall only be deemed valid if:

- The product does not exhibit any damage or signs of wear caused by a form of use deviating from normal intended use or the specifications provided by FAZUA GmbH in the user manual.
- The product does not exhibit any signs indicating that repairs or other procedures were performed by anyone not authorized by FAZUA GmbH.
- The damage is not due to improper assembly or follow-up maintenance or lack of skill, competence or experience of the user or assembler.
- The product was assembled or serviced by an authorized Fazua dealer.

- The product has not been modified, neglected, used in competition, or for commercial purposes such as rental, courier, police, security, etc., misused or abused, involved in accidents or anything other than normal use.
- There was no installation of components, parts, or accessories not originally intended for use with or compatible with Fazua Products.
- The serial number has not been removed or rendered illegible.
- Notice of the defect has been given within fourteen (14) days of the discovery of the defect.

Claims under this warranty require that,

- prior to returning the product, the customer contact either the dealer from whom the customer purchased the bicycle or FAZUA GmbH, and that the customer gives the dealer or FAZUA GmbH an opportunity to perform a fault analysis over the telephone within a period of eight days.
- the product is delivered or returned to FAZUA GmbH.
- the original invoice containing the date of purchase is presented.
- the shipping is carried out by a carrier designated by FAZUA GmbH. The customer may use a different carrier at his or her own expense.

In the event of resale, this warranty shall also apply within the aforementioned scope, and under the conditions stated above (including the requirement to provide proof of purchase) to any subsequent future owner of the Product. Each new owner assumes the warranty based on the time remaining from the original date of purchase. In consideration of the above warranties by FAZUA GmbH, the buyer agrees to and accepts the following conditions:

- This warranty is subject to the law of the US, provided that mandatory consumer protection regulations in the country of the respective Customer are not in conflict therewith.
- That this warranty is in lieu of all other warranties, expressed or implied.
- That ALL WARRANTIES OF MERCHANTABILITY OR OF FITNESS FOR A PARTICULAR PURPOSE ARE HEREBY EXCLUDED AND/OR WAIVED.
- That this remedy is in lieu of all other remedies or claims for damages, consequential or otherwise, which the buyer may have against FAZUA GmbH.
- FAZUA GmbH shall have no liability for any loss or injury caused, in whole or in part, by its actions, omissions, or negligence, or for contingencies beyond its control.

## 10 SERVICE



**Authorized specialists** for repair and maintenance work can be found with the official Fazua service partners. Contact the Fazua service team or visit the Fazua service platform to find Fazua service partners for your region.



If possible, prepare the error image and all information on the relevant component before contacting a FAZUA Certified Partner or the FAZUA service team.

→ If service is required, contact a FAZUA Certified Partner or the FAZUA service team.

→ Visit the FAZUA service platform, if necessary:

<https://fazua.com/de/support>.

You will find extensive content here on the subject of "Service", as well as a search function for locating a FAZUA Certified Partner in your area.

## 11 CONFORMITY

FAZUA confirms conformity according to 47 CFR Section 15.19 – Information for the user.

This device complies with part 15 of the FCC Rules. Operation is subject to the following two conditions:

1. This device may not cause harmful interference, and
2. this device must accept any interference received, including interference that may cause undesired operation.

FAZUA confirms the conformity according to 47 CFR Section 15.21 - Information for the user.

NOTE: This equipment has been tested and found to comply with the limits for a Class B digital device, pursuant to part 15 of the FCC Rules. Any changes or modifications not expressly approved by the party responsible for compliance could void the user's authority to operate the equipment. These limits are designed to provide reasonable protection against harmful interference in a residential installation. This equipment generates, uses and can radiate radio frequency energy and, if not installed and used in accordance with the instructions, may cause harmful interference to radio communications. However, there is no guarantee that interference will not occur in a particular installation. If this equipment does cause harmful interference to radio or television reception, which can be determined by turning the equipment off and on, the user is encouraged to try to correct the interference by one or more of the following measures:

- Reorient or relocate the receiving antenna.
- Increase the separation between the equipment and receiver.
- Connect the equipment into an outlet on a circuit different from that to which the receiver is connected.
- Consult the dealer or an experienced radio/TV technician for help.

# DRIVE UNIT

## 12 FUNCTIONALITY AND MODEL VARIANTS OF THE DRIVE UNIT

The drive unit converts the energy of the battery and supports you while pedaling. The speed sensor on the rear wheel determines the driving speed (with the help of a magnet). If the determined cycling speed exceeds the switch-off point\*, the drive unit automatically switches off the electric pedal assist. As soon as the cycling speed drops below the switch-off point, the electric pedal assist starts again.

**IMPORTANT:** Drive unit and speed sensor are permanently installed on your e-bike and may not be modified. If you make changes to the drive unit or to the speed sensor itself, this may impair the safety and function of the drive system.

## 13 ILLUSTRATIONS FOR THE DRIVE UNIT

### 13.1 Detail view and part designations/positions on the e-bike

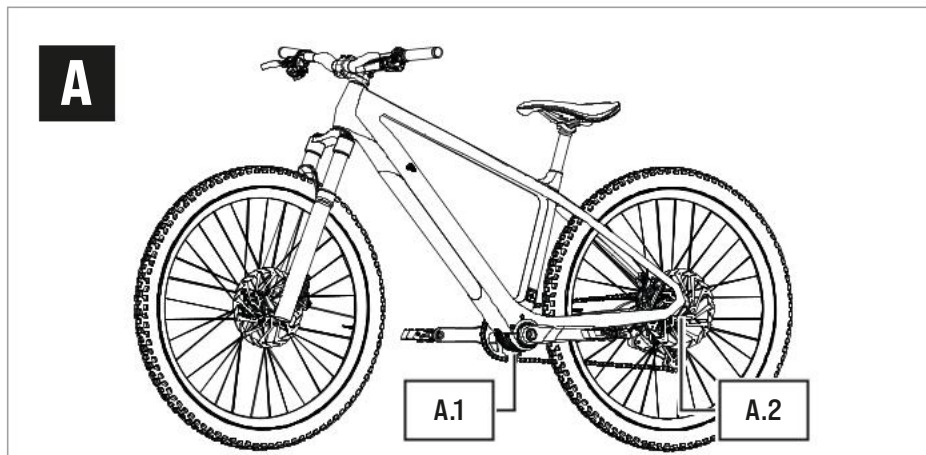

#### Part designations

- A.1 → Drive unit (permanently installed component)
- A.2 → Speed sensor + magnet

\* The electric pedal assist switches off as soon as you reach or exceed a certain (country and product specific) speed

## 14 TECHNICAL DATA ON THE DRIVE UNIT

Article number	→ 10A101000A/10A101100A
Continuous rated power	→ 250 W
[Mechanical] power, max.	→ 450 W
Nominal voltage	→ 43.2 V
Support torque, max.	→ 60 Nm
Pedaling cadence [range]	→ 55–125 rpm
Protection type	→ IP54
Weight, approx.	→ 4.3 lbs (1.95 kg)
Operating temperature	→ 23 °F to 113 °F [-5 °C to +45 °C] [ambient temperature]
Storage temperature [< 1 month]*	→ 5 °F to 140 °F [-15 °C to +60 °C]

## 15 CORRECT POSITION OF SPEED SENSOR AND MAGNET



For the drive system to function correctly, the speed sensor and magnet [A.2] must be mounted in the correct position on the rear wheel. If this is not the case or if the speed sensor is not connected correctly, the drive system will operate in "Soft Fault" mode.

→ You can find detailed information here in Chapter 20.1 "E-bike status".

- If you find that the drive system is in "Soft Fault" mode, make sure the Speed Sensor and magnet are correctly located in their holder on the rear wheel.
- If the problem cannot be solved, do not use the e-bike but contact an authorized specialist.

\* The specification only applies if your e-bike is equipped with a removable battery and you have removed the battery before storage (See Chapter 23 "Function and model variants of the battery").

## 16 CLEANING AND MAINTAINING THE DRIVE UNIT



### WARNING

**Danger from accidental starting!**

If the drive system is set in motion while you are handling it, you may injure yourself.

- ▶ To prevent the drive system from being set in motion, switch off the drive system and, if necessary, secure it against being switched back on unintentionally or unnoticed when cleaning the e-bike or the components of the drive system. If necessary, remove the battery before cleaning to prevent unintentional start-up.\*

### NOTE

**Risk of damage!**

Improper cleaning can damage the drive unit.

- ▶ Never clean the drive unit with a hard water jet or a high-pressure cleaner.
- ▶ Do not use aggressive cleaning agents for cleaning.
- ▶ Do not use sharp, angular or metallic cleaning objects when cleaning.
- Always keep all components of the e-bike and the drive system in a clean condition.
- Clean the exterior of the drive unit gently with a cloth or soft brush.
- If necessary, use a mild soap solution for the external removal of coarser soiling.
- Wipe all surfaces dry after cleaning.

**IMPORTANT:** Pay particular attention to the contacts and interfaces between the battery and drive unit\*: The interfaces may not be soiled or contaminated and must be completely dried before inserting the battery to avoid damage.

- Clean the cooling unit of the drive unit regularly.  
Do not wait until the cooling unit is visibly or heavily soiled before cleaning it!
- For more information on cleaning and maintaining your drive system, contact a FAZUA service partner or visit the FAZUA service platform (<https://fazua.com/de/support>).

\* This applies only if your e-bike is equipped with a removable battery (See Chapter 23 "Function and model variants of the battery").

# CONTROL ELEMENT AND DISPLAY

## 17 FUNCTIONALITY AND MODEL VARIANTS OF THE CONTROL ELEMENT AND DISPLAY

Use the control panel to make all settings for the drive system; the display provides information on current settings and battery charge level.



Depending on the model, the control element and display are either:

- a combined component (model: Control Hub);
- Or
- two separate components located in different mounting locations on the e-bike (models: Ring Control; LED Hub).

## 18 CONTROL ELEMENT AND DISPLAY ILLUSTRATIONS

### 18.1 Detailed view and part designations

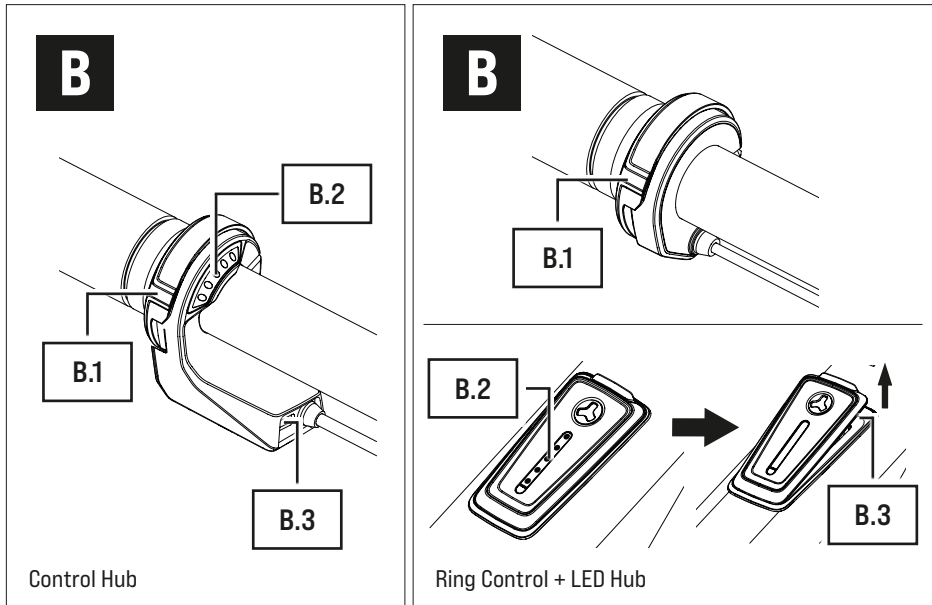

### Part designations

- B.1 → Control switch
- B.2 → LED display
- B.3 → USB port

## 18.2 Positions on the e-bike

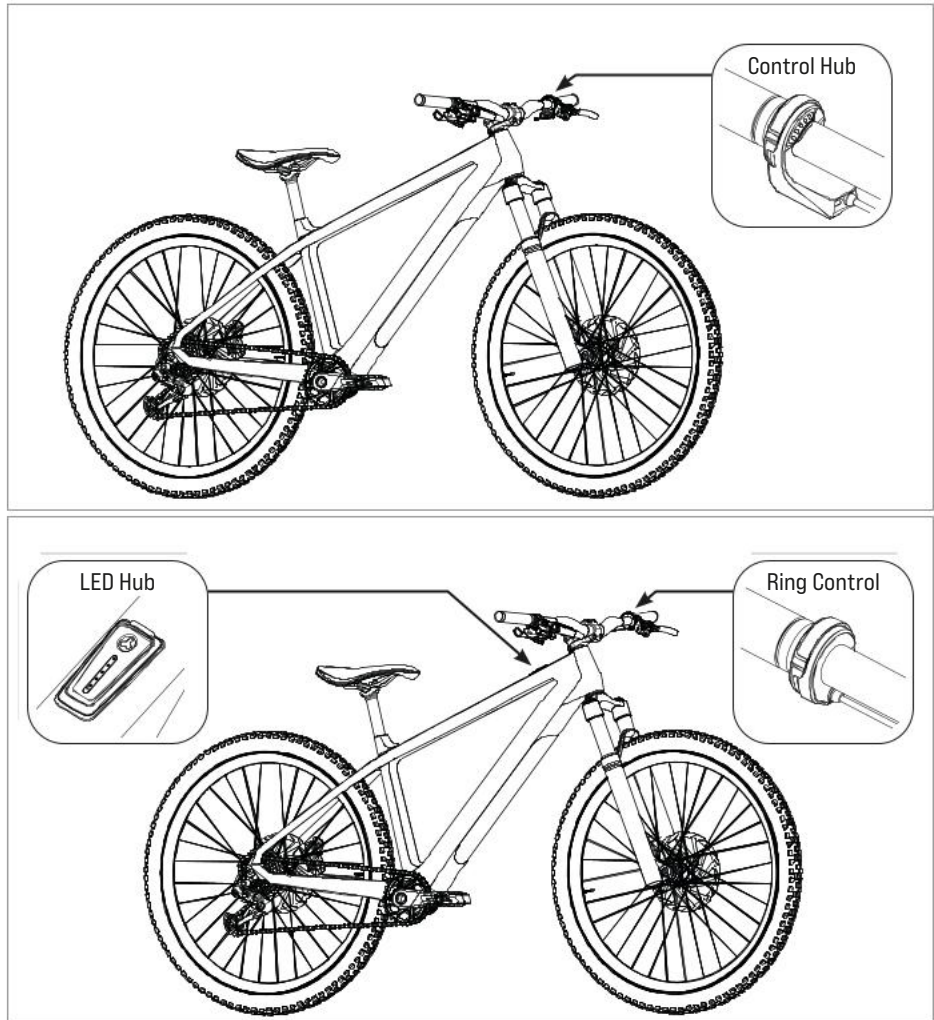

## 19 TECHNICAL DATA FOR THE CONTROL ELEMENT AND DISPLAY

Model designations	
Combined component	→ Control Hub [control element, including the display]
Separate components	→ LED Hub [= display] Ring Control [= control element]
Degree of protection (in assembled condition)	→ IP54
Operating temperature	→ 23 °F to 113 °F [-5 °C to +45 °C] [ambient temperature]
Storage temperature [< 1 month]*	→ 5 °F to 140 °F [-15 °C to +60 °C]

## 20 DRIVING AND STATUS INFORMATION ON THE DISPLAY

The LED display [B.3] has 5 LEDs.

- All five LEDs together serve as a display for the charge level and the set assistance level of the pedal assist.
- The upper of the five LEDs (see arrow in figure on the right) additionally informs you about the status of your e-bike.

### 20.1 E-bike status

The upper LED on the display indicates a status change or a pending fault.

Depending on which status is displayed, the LED of the status indicator lights up in different colors.

If no fault is detected, the LED will act as one of the five LEDs that indicate the charge level or set assistance level.

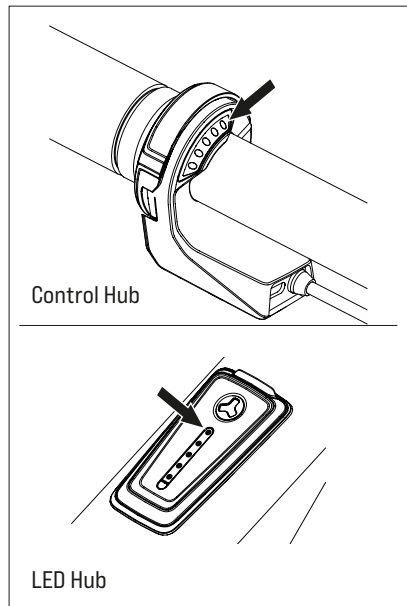

\* The specification only applies if your e-bike is equipped with a removable battery and you have removed the battery before storage (See Chapter 23 "Function and model variants of the battery").

## Possible status displays

- The upper LED **flashes green** = **"Ready for operation"**  
After successful installation of the battery in the e-bike, the status indicator flashes green briefly to indicate that you can now switch on the drive system using the control element.
- The upper LED **flashes yellow** = **"Soft Fault"**  
When a "Soft Fault" occurs, the status indicator flashes yellow. The drive system signals that a temporary or non-critical fault is present, which in most cases leads to a loss of power.  
If a "Soft Fault" occurs, you can continue riding your e-bike, but FAZUA strongly advises against doing so in order to avoid further damage to the drive system or e-bike.
- The upper LED **flashes red** = **"Hard Fault"**  
When a "Hard Fault" occurs, the status indicator flashes red. If a "Hard Fault" occurs on your e-bike, the e-bike can no longer be operated and must be serviced.

## 20.2 Current charge level and set support level

All five LEDs of the LED display [B.2] together indicate two parameters.

### 1. The battery charge level indicator:

The charge level of the battery can be read from the number of illuminated LEDs. Each of the 5 LEDs represents 20% of the total charging capacity.

When the battery is fully charged, all 5 LEDs light up. If the battery is flat, the upper LED of the status indicator lights up white or no LED lights up.

### 2. The selected assistance level of the pedal assist:

Each support level is assigned a color; i.e. the color of the LEDs on the display indicates the currently set support level.

→ You can find detailed information here in Chapter 21.3 "Levels of support".

## 21 USING THE CONTROL ELEMENT

### WARNING

#### Danger due to distraction during operation!

If you are distracted by shifting gears on the control or looking at the display while cycling, accidents and serious injury may result.

- ▶ Before using your e-bike for the first time, familiarize yourself with the functions and handling of your control element away from road traffic.
- ▶ Do not use the control element and do not look at the display while riding if it distracts you.

### 21.1 Switching the drive system on and off

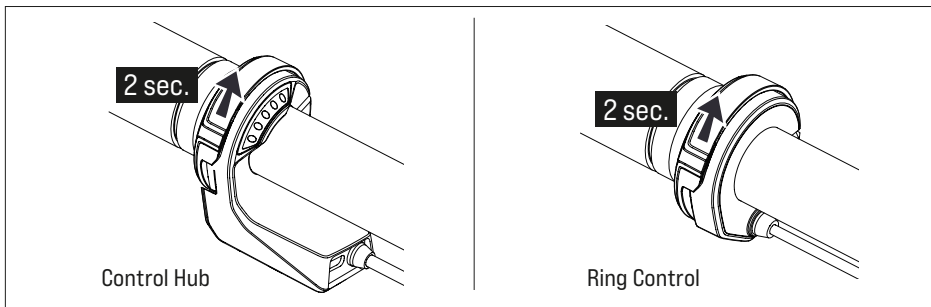

→ To **switch on**, keep the operating switch [B.1] pressed up (for at least 2 seconds).

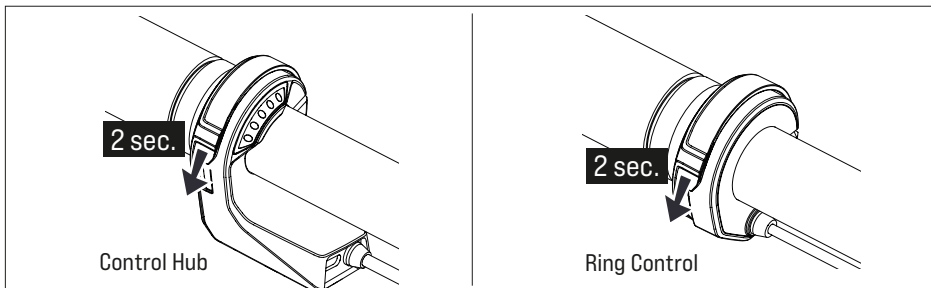

→ To **switch off**, keep the operating switch [B.1] pressed down (for at least 2 seconds).

## 21.2 Setting the pedal support

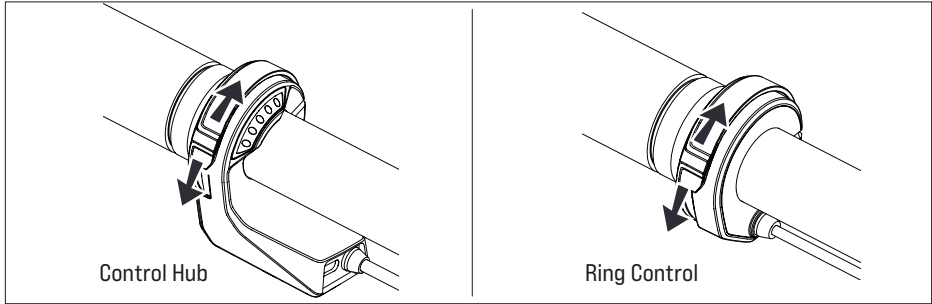

You can set or change the assistance level either while cycling or while stationary.

- To switch to the **next higher** support level:  
Press the **operating switch [B.1]** 1× briefly **upwards**.
- To switch to the **next lower** support level:  
Press the **operating switch [B.1]** **down** 1× briefly.

## 21.3 Levels of support

**No support (white)** The LED display [B.2] lights up white.

- You ride without electric pedal support (as with a conventional bicycle).

**Assistance level "Breeze"** The LED display [B.2] lights up green.

- You ride with low but effective support for maximum range.

**Assistance level "River"** The LED display [B.2] lights up blue.

- You ride with reliable support for most applications.

**Assistance level "Rocket"** The LED display [B.2] lights up pink.

- You ride with maximum support for very demanding trips.



You can check and individually adjust the maximum motor power using the FAZUA Toolbox or the FAZUA app.

→ See in Chapter 5 "FAZUA app" for more information on the FAZUA app.

## 21.4 Boost function

In addition to the "regular" support levels, which you can use at any time\*, the drive system has an additional function: The Boost function allows you to ride with a (higher) maximum motor power of 450 watts for a short time to momentarily give you an extra push.

The duration of the extra push due to the Boost function depends on the situation in which you activate the Boost function:

- If you activate the Boost function **from a standstill**, you receive an extra push for **4 seconds**.
- If you activate the Boost function **while already riding**, you receive an extra push for **12 seconds**.

**To activate the Boost function:**

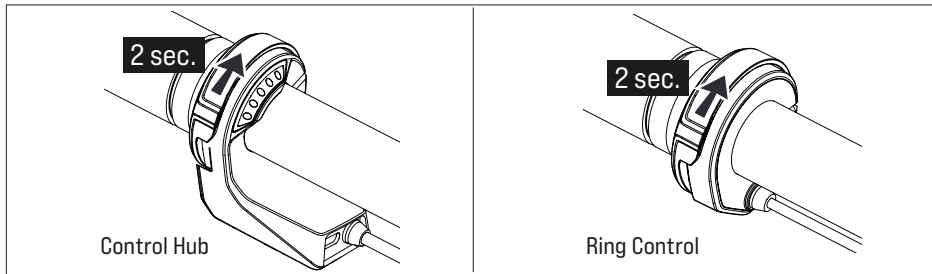

→ Press and hold the operating switch **[B.1]** upwards (for at least 2 seconds).

The Boost function is deactivated automatically after 4 or 12 seconds or when you stop pedaling (e.g. to brake).



The Boost function cannot be activated if:

- you are riding at a speed of more than 25 km/h / 20 mph.
- you have not selected an assistance level (the LEDs on the display light up white).

\* depending on the charge level of the battery.

## 21.5 "Push Assist" mode

### WARNING

**Danger due to distraction during operation!**

Starting the drive system in unsuitable situations can result in accidents and serious injury.

- ▶ Use the "Push Assist" function only when pushing the e-bike.
- ▶ When the push assist is activated, hold the e-bike securely with both hands and make sure that the wheels are in contact with the ground.

### CAUTION

**Risk of injury!**

If you push the e-bike with the push assist activated, the pedals rotate slowly and you may be injured.

- ▶ Be careful not to injure yourself on the rotating pedals when using the "Push Assist" function.



The "Sliding support" mode is a model-dependent function of the control. The following controls have the "slide support" mode:

- Control Hub
- Ring Control

### 21.5.1 General information about the mode

The push assist facilitates the pushing of the e-bike. In "Push Assist" mode, your e-bike can reach a speed of up to 6 km/h / 3.7 mph depending on the gear selected. You can slow down the speed of the e-bike to your walking speed by holding or restraining the e-bike.

The push assist is automatically disabled if:

- You release the operating switch,
- The wheels on the e-bike are locked,
- the e-bike reaches a speed of more than 6 km/h. / 3.7 mph.

### 21.5.2 Using "Push Assist" mode

1. Set the assistance level to "none".
2. Press and hold the control switch **[B.2]** towards the center of the handlebar to use the push assist. After 2 seconds, push assist is activated and sets the e-bike in motion as long as you keep the control switch pressed.
3. Guide the e-bike with both hands and, if necessary, brake the speed of the e-bike to your own walking speed by holding or restraining the e-bike while pushing.
4. Switch off the push assist by releasing the control switch.

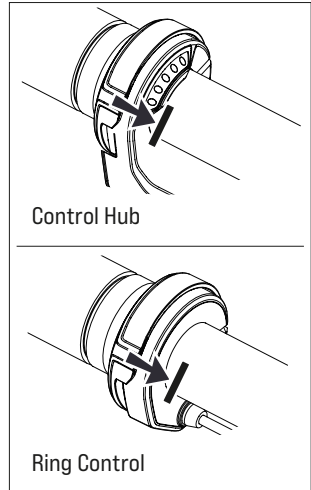

### 21.6 Switching the bicycle lighting on and off



This function depends on the model and is only available when a bicycle light is connected.

- Press the control switch **[B.1]** 1× briefly towards the center of the handlebar to switch on the bike lights.
- Press the control switch **[B.1]** again 1× briefly towards the center of the handlebar to switch the bike lights off again.

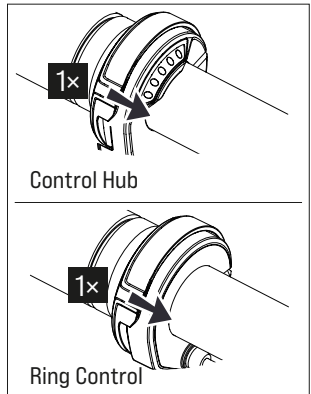

### 21.7 Bluetooth® connection

You can connect your cell phone to your drive system via the FAZUA app. Once the connection has been successfully established, the five LEDs of the LED display **[B.2]** flash blue 3 times.

- See in Chapter 5 "FAZUA app" for more information on the FAZUA app.

## 22 *CLEANING AND MAINTAINING THE CONTROL ELEMENT AND DISPLAY*

### **WARNING**

#### **Danger from accidental starting!**

If the drive system is set in motion while you are handling it, you may injure yourself.

- ▶ Be careful not to start the drive system unintentionally when cleaning the control element. If necessary, remove the battery before cleaning to prevent unintentional start-up\*.

### **NOTE**

#### **Risk of damage!**

Improper cleaning may damage the control element or display.

- ▶ Never immerse the control element and display in water or other liquids for cleaning.
  - ▶ Do not use aggressive cleaning agents for cleaning.
  - ▶ Do not use sharp, angular or metallic cleaning objects when cleaning.
- Always keep all components of the e-bike and the drive system in a clean condition.
- Clean the exterior of the control element and display gently with a cloth or soft brush.
- If necessary, use a mild soap solution for the external removal of coarser soiling.

**IMPORTANT:** Dampen the cloth only slightly or wring it out well to prevent liquid from penetrating the inside of the housing and the connections. If liquid enters the inside of the housing or the connections, the control element and the display may be damaged.

- Wipe all surfaces dry after cleaning.

\* This applies only if your e-bike is equipped with a removable battery (See Chapter 23 “Function and model variants of the battery”).

# BATTERY AND CHARGER

## 23 FUNCTION AND MODEL VARIANTS OF THE BATTERY

The battery acts as an energy supply for the electric pedal assist of your e-bike. Use the charger to charge the battery.



Depending on the model, the battery is either:

- permanently installed in the e-bike and cannot be removed from it;
- Or
- a separate component that can be removed from the e-bike.

## 24 BATTERY AND CHARGER ILLUSTRATIONS

### 24.1 Detailed view and part designations

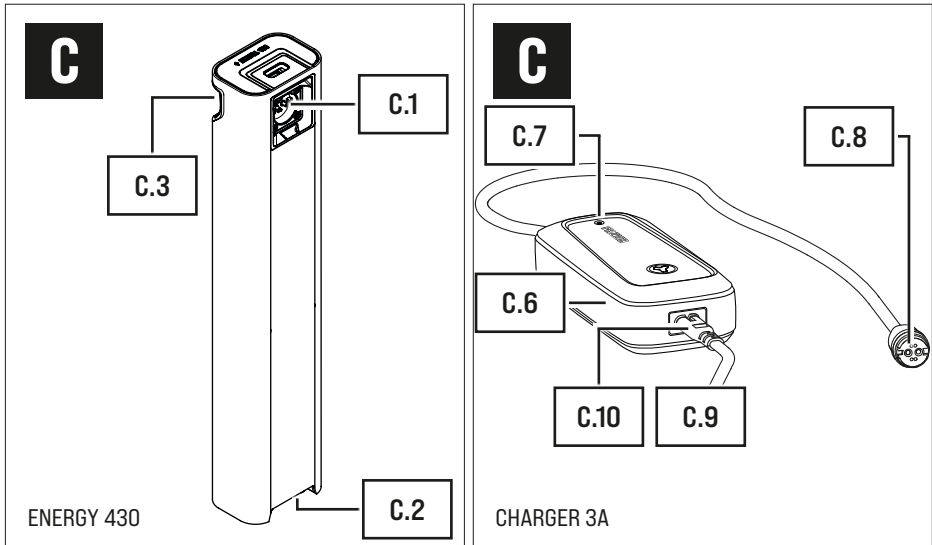

#### Part designations

- C.1 → Charging port\* (battery)  
 C.2 → Interface\* (battery interlock)  
 C.3 → Push button\* (battery lock)

\* Applies only to removable batteries, not to permanently installed batteries.

## Part designations

- C.4 → Cylinder lock and key\*
- C.5 → Charging socket with cover flap\*\* (e-bike)
- C.6 → Mains adapter
- C.7 → LED display
- C.8 → Charging plug
- C.9 → Mains cable with mains plug\*\*\* (power connection)
- C.10 → Plug

## 24.2 Position on e-bike

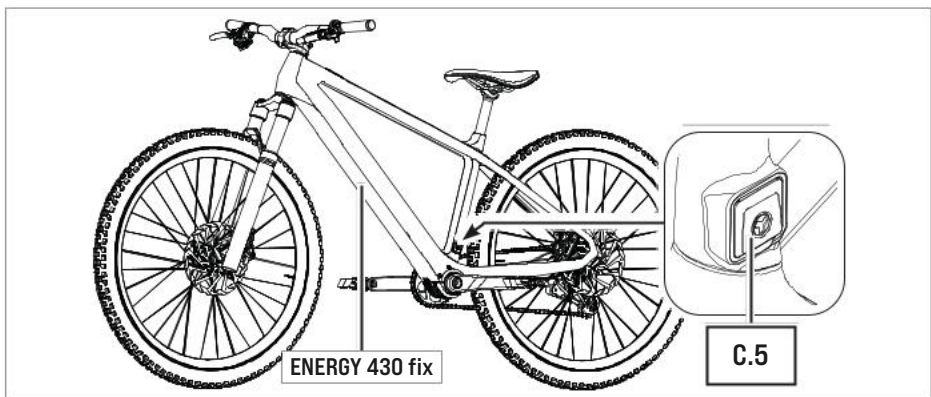
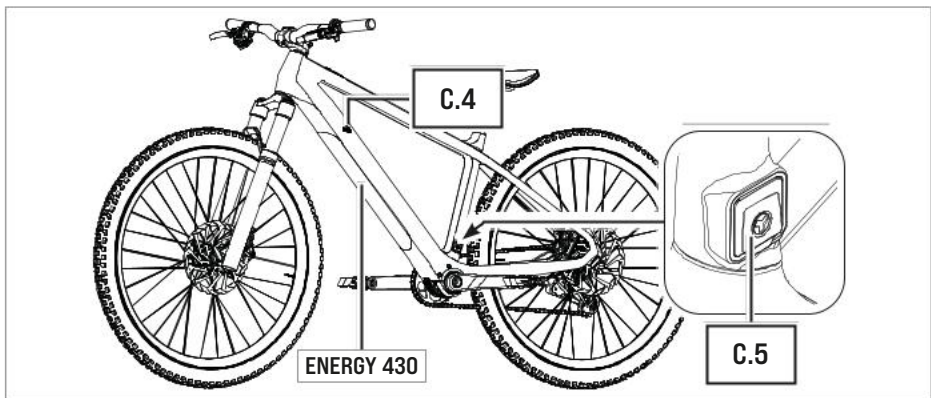

\* Applies only to removable batteries, not to permanently installed batteries.

\*\* Applies to removable and permanently installed batteries. The charging connection is optional. The position could vary depending on the individual manufacturer.

\*\*\* Different from country to country, therefore without illustration.

## 25 TECHNICAL DATA FOR BATTERY AND CHARGER

### 25.1 Technical data on the battery

Model designations	
Permanently installed battery	→ FAZUA ENERGY 430 fix
Removable battery	→ FAZUA ENERGY 430
Weight, approx.	→ 4.85 lbs [2.2 kg]
Operating temperature	→ 23 °F to 104 °F [-5 °C to +40 °C] [ambient temperature]
Storage temperature (< 1 month)*	→ 5 °F to 140 °F [-15 °C to +60 °C]
Storage temperature (> 1 month)*	→ 5 °F to 77 °F [-15 °C to +25 °C]

### 25.2 Technical data on the charger

Model designation	→ CHARGER 3A (Model STC-8207LD)
Nominal input voltage	→ 100–240 V AC
Frequency	→ 47–63 Hz
Charging current	→ 3 A
Charging time, approx.	→ 3.5 h
Protection class	→ 2 [symbol: 
Protection type	→ IP54 (when plugged in)
Weight, approx.	→ 1.32 lbs [0.6 kg]
Operating temperature	→ 32 °F to 95 °F [0 °C to +35 °C]
Storage temperature	→ 32 °F to 113 °F [0 °C to +45 °C]

## 26 GENERAL SAFETY INSTRUCTIONS FOR THE BATTERY AND CHARGER



**DANGER**

**Batteries may explode!**

If you use inappropriate batteries or do not handle the battery properly, the battery may explode.

- ▶ Only use the original FAZUA charger for charging.
- ▶ Never use a damaged battery!
- ▶ Never attempt to charge a damaged battery!

\* Please also note the information on the storage time-dependent temperature ranges for the battery in Chapter 4 "Storage and transport of e-bikes with the FAZUA drive system".

- ▶ Never open the battery! Attempting to open a battery increases the risk of explosion!
- ▶ Keep the battery away from heat (e.g. strong sunlight), open fire or water or other liquids.
- ▶ Only use the battery in e-bikes equipped with an original FAZUA RIDE 60 drive system. Never use the battery for other purposes or in other drive systems.

 **DANGER****Fire hazard due to incorrect handling!**

Improper handling of the battery and/or charger or attempting to charge batteries with an incompatible charger could cause a fire.

- ▶ Only use original and compatible components from FAZUA with each other! Do not attempt to charge an unfamiliar battery with the FAZUA charger and do not attempt to charge the FAZUA battery with an unfamiliar charger.
- ▶ The charger and battery heat up during charging, so keep away from combustible materials and do not leave the two components unattended during charging. During charging place the charger and battery on a well ventilated surface.
- ▶ Never attempt to charge non-rechargeable batteries!
- ▶ Take care not to handle metal objects such as coins, paper clips, screws, etc. in the immediate vicinity of the battery and to store the battery separately from metal objects. Metal objects can close a circuit between the terminals of the battery (i.e. "short-circuit" the battery) and cause a fire as a result.
- ▶ Do not short-circuit the battery.

 **DANGER****Risk of electric shock!**

Improper handling of the charger or incorrect mains connection may expose you and others to the risk of electric shock.

- ▶ Only connect the charger to an easily accessible and properly installed power outlet.

- ▶ Make sure that the mains voltage at the mains connection corresponds to the information on the charger.
- ▶ Only use the charger in dry indoor areas.
- ▶ Keep the charger away from any liquid or moisture.
- ▶ Do not pull on the cables, but always grasp the corresponding plug when disconnecting the connectors.
- ▶ Do not handle the plugs of the charger with wet or damp hands.
- ▶ Take care not to bend the charger cable or lay them over sharp edges.
- ▶ Do not open the charger without authorization. The charger may only be opened by an authorized specialist and repaired using original spare parts.
- ▶ Before each use of the charger, check all individual parts (mains adapter, mains cable, charger cable and all plugs) for damage. If the charger's power cord is damaged, it must be replaced by the manufacturer, their customer service or a similarly qualified person, to avoid hazards.
- ▶ Never use a damaged charger. Otherwise there is a high risk of electric shock!
- ▶ Keep the charger in a clean condition. There is an increased risk of electric shock if the charger is dirty or contaminated.

 **DANGER****Dangers during unattended use!**

If children (younger than 14) or people with physical or mental impairments handle the battery or charger, there is an increased risk potential as these user groups may not be able to correctly assess certain risks, for example.

- ▶ This appliance is not intended for use by children (younger than 14) and persons (including children) with reduced physical, sensory or mental capabilities, or lack of experience and knowledge, unless they have been given supervision or instruction concerning use of the appliance by a person responsible for their safety.
- ▶ Children shall not play with the appliance.
- ▶ Only for rechargeable li-ion battery.

- ▶ Do not attempt to disassemble the charger by yourself.
- ▶ Do not use the charger in high temperature, moist, inflammable or explosive outdoor environments.
- ▶ Disconnect the power supply before marking or breaking the connections to the battery.

 **DANGER**

**Danger of impairment of medical devices!**

The magnetic connections in the battery and charger can interfere with the function of pacemakers.

- ▶ Keep the battery and charger away from pacemakers or persons wearing a pacemaker and draw the attention of persons with pacemakers to the danger.

 **DANGER**

**Risk of caustic burns due to battery acid!**

The battery contains battery acid. If you come into contact with this fluid, the affected skin area and/or mucous membrane may be burnt. Eye contact can cause loss of vision.

- ▶ Do not touch any liquid leaking from the battery.
- ▶ If you have come into contact with liquid leaking from the battery, immediately rinse the affected part of the body thoroughly under plenty of running water.
- ▶ Consult a doctor immediately after rinsing, especially in case of eye contact and/or if mucous membranes (e.g. nasal mucosa) are affected.

 **WARNING**

**Health hazard due to irritation of the respiratory tract!**

If the battery is damaged, gases may escape which may irritate the respiratory tract.

- ▶ Protect the battery from mechanical influences and any other load.
- ▶ If you notice or suspect that gas is leaking from the battery, immediately ensure a supply of fresh air and seek medical attention as soon as possible.

**⚠ WARNING**  
Risk of burns!

The cooling unit on the drive unit can become very hot during operation and you may burn yourself when touching it.

- ▶ Be careful when handling the battery. If necessary, allow the drive unit to cool down completely first.

**NOTE**  
Risk of damage!

Improper handling can damage the drive system or individual components.

- ▶ Before inserting the battery, make sure that the contacts inside the drive unit and on the battery are dry. If the contacts are damp or wet when inserted, the battery may be damaged.
- ▶ When charging the battery, make sure that the cable labels of the charger are not trip hazards in order to prevent components from being damaged, e.g. by a fall.
- ▶ Always make sure that the cover flap of the charging socket on the e-bike is closed correctly and completely to ensure that no dust or splash water can enter the charging socket.

## 27 USING THE BATTERY

### 27.1 Inserting the battery on the e-bike/removing it from the e-bike



This applies only if your e-bike is equipped with a removable battery (See Chapter 23 “Function and model variants of the battery”).

#### 27.1.1 Inserting the battery

**⚠ DANGER**  
Risk of explosion and fire!

A damaged or dirty battery may explode and/or cause a fire.

- ▶ Never insert a damaged battery into the e-bike.

- ▶ Check the battery for visible damage, such as cracks or burn marks, before each insertion.
  - ▶ Make sure that the interfaces on the battery are free of dirt before using it.
1. Check the battery for visible damage before insertion (visual check).
  2. Place the battery with the interface [C.2] first on the corresponding interface on the e-bike.

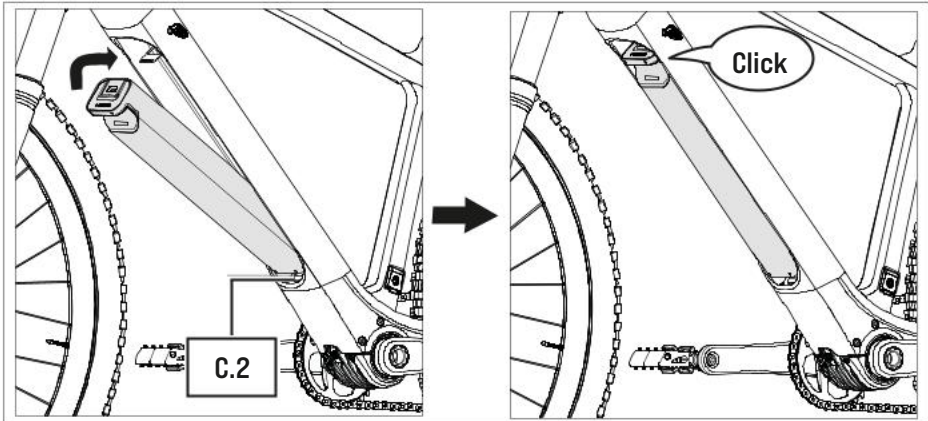

3. Swing the upper end of the battery into the down tube of the e-bike.  
 The battery is automatically locked in place when the two interfaces on the battery and e-bike are correctly interlocked and the battery is swiveled fully into the designated receptacle on the down tube. An audible engagement sound ("click") is heard when the device engages.  
 Contact an authorized specialist if the battery cannot be inserted/if the battery does not (audibly) engage on the e-bike.

### 271.2 Removing the battery

#### **WARNING**

**Risk of burns and injury!**

The cooling unit on the drive unit can become very hot during operation and you may burn yourself when touching it. You may trap your fingers when removing the battery without due care.

- ▶ Be careful when handling the battery. If necessary, allow the drive unit to cool down completely first.

► When pressing the push button or removing the battery, be careful not to pinch your fingers.

1. Secure the battery with one hand.
2. Reach into the cutout on the battery and push the elastic pushbutton [C.3] in as far as it will go.

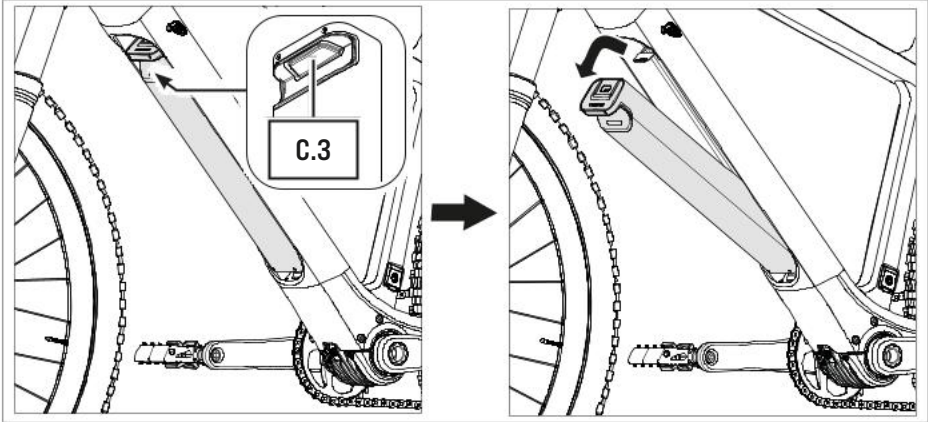

3. Press and hold the push button and gently pull the battery forwards out of the battery holder.
4. Remove the battery from the interface on the e-bike.

## 27.2 Checking the charge level and SOH of the battery



This applies only if your e-bike is equipped with a removable battery (See Chapter 23 “Function and model variants of the battery”).

### Checking the SOH/current charge level of the battery

→ Tilt the battery back and forth to check the current charge level (e.g., before or during a [longer] trip).

Depending on the charge level, different numbers of LEDs light up on the display in the battery section. Each LED represents 20% of the capacity. If all five LEDs are lit, the battery is fully charged.

**IMPORTANT:** The charge level indicator is not designed to be used during the charging process to ascertain whether the battery has already reached maximum charge or whether it can still be charged. You can use the LED indicator [C.7] on the charger for this purpose.

→ You can find detailed information here in Chapter 28.3 “Charging process”.

## Checking the SOH

The "aging state" of the battery, the so-called SOH ("state of health"), can be queried via the FAZUA Service Toolbox and via the FAZUA app.

→ For the query, connect the e-bike (with inserted battery) via the USB socket\* to a computer with access to the FAZUA Service Toolbox or open the FAZUA app\*\*.

## 28 CHARGING THE BATTERY



**DANGER**

**Risk of electric shock!**

Improper handling of the charger or incorrect mains connection may expose you and others to the risk of electric shock. Improper handling of the battery and/or charger or attempting to charge batteries with an incompatible charger could cause a fire.

► Read and follow the safety instructions in Chapter 26 "General safety instructions for the battery and charger" before charging the battery.

Regularly charge the battery via the charging socket [C.5] on the e-bike (See Chapter 28.2.1 "Charging the [integrated] battery in the e-bike").

If you have a removable battery, you can alternatively remove it from the e-bike and charge it separately (See Chapter 28.2.2 "Charging the battery separately").

The charging process can be interrupted at any time.

**IMPORTANT:** Charge the battery **only within the specified temperature range**. Charging outside the specified temperatures may damage the charger or battery.

→ Fully charge the battery prior to initial operation so that you can use the full capacity of the battery.

### 28.1 Prepare charger

1. Pick up the mains adapter [C.6] and the power cord [C.9].
2. Plug the appliance plug [C.10] of the mains cable into the corresponding socket [on the mains adapter].

\* The USB cable is not supplied.

\*\* See in Chapter 5 "FAZUA app" for more information on the FAZUA app.

## 28.2 Connecting the charger

### 28.2.1 Charging the (integrated) battery in the e-bike

1. Open the cover flap to access the charging socket [C.5] on the e-bike.
2. Insert the charging plug [C.8] into the charging socket [C.5].

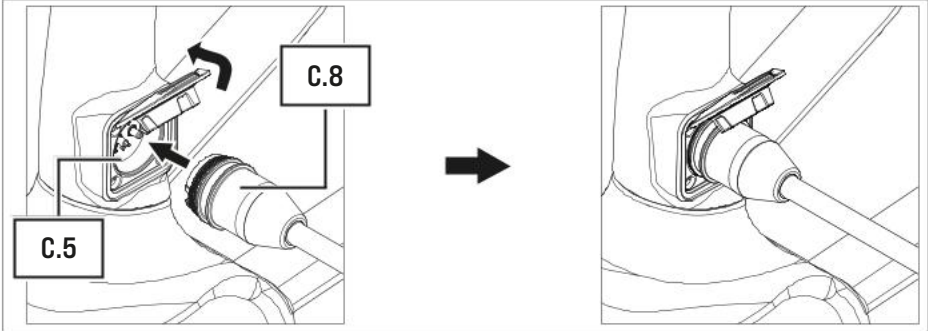

3. Plug the power plug [C.9] into a suitable wall outlet to establish the power connection.

### 28.2.2 Charging the battery separately

1. Remove the battery from the e-bike (See Chapter 27.1.2 “Removing the battery”).
2. Insert the charging plug [C.8] into the charging connection [C.1] on the battery.

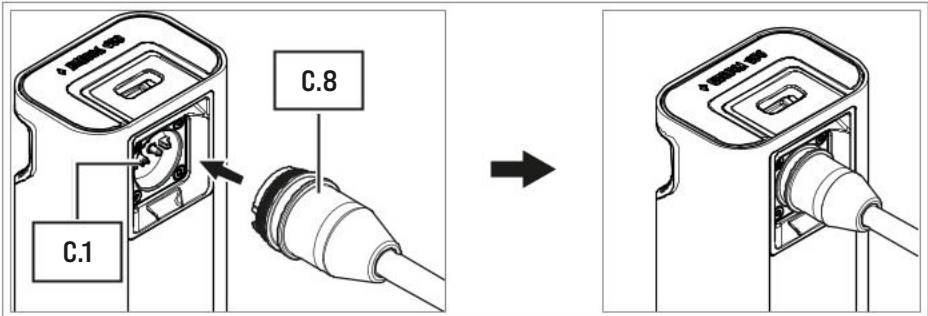

3. Plug the power plug [C.9] into a suitable wall outlet to establish the power connection.

## 28.3 Charging process

The charging process begins as soon as you have connected the charger to the e-bike or battery on one side and to the power supply on the other.

The flashing LEDs on the battery charge indicator indicate that the battery is being charged.\*

\* Applies only to removable batteries, not to permanently installed batteries.

During the charging process, the **LED indicator [C.7]** on the mains adapter lights up **red** to indicate that the **battery is charging**.

When the color of the **LED indicator [C.7]** switches to **green**, this indicates that the **battery is fully charged**.

### **28.4 Unplug charger from battery**

1. When charging is complete, unplug the mains plug **[C.9]** from the outlet to disconnect the charger from the mains.
2. Then disconnect the charger from the e-bike/battery by pulling the charging plug **[C.8]** out of the charging socket **[C.5]** on the e-bike or out of the charging connection **[C.1]** on the battery.

**IMPORTANT:** Close the cover flap of the charging socket again after the charging process and ensure that the charging socket is correctly closed.

3. If necessary, reinsert the battery into the e-bike.\*
4. Then disconnect the mains cable **[C.9]** from the mains adapter **[C.6]** and keep the two parts separate.

## **29 CLEANING THE BATTERY AND CHARGER**

### **NOTE**

**Risk of damage!**

Improper cleaning can damage the battery or the charger.

- ▶ Never immerse the battery or the charger in water or other liquids. Keep liquids away from the battery and charger.
- ▶ Do not use aggressive cleaning agents for cleaning.
- ▶ Do not use sharp, angular or metallic cleaning objects when cleaning.
- ▶ Always keep all components of the e-bike and the drive system in a clean condition.



**IMPORTANT:** The cleaning instructions for the battery only apply to removable batteries (See Chapter 23 “Function and model variants of the battery”). If your e-bike is equipped with a permanently installed battery, you do not need to clean it separately!

\* Applies only to removable batteries, not to permanently installed batteries.

## 29.1 *Cleaning the battery*

- Clean the exterior of the battery gently with a cloth or soft brush.
- If necessary, use a mild soap solution for the external removal of coarser soiling.

**IMPORTANT:** Dampen the cloth only slightly or wring it out well to prevent liquid from penetrating the inside of the housing and the contacts/interfaces. If liquid gets into the inside of the housing or into the contacts/interfaces, the battery may be damaged and electrical safety may be impaired.

- Wipe all surfaces dry after cleaning.

**IMPORTANT:** Pay particular attention to the contacts and interfaces between the battery and drive unit\*: The interfaces may not be soiled or contaminated and must be completely dried before inserting the battery to avoid damage.

## 29.2 *Cleaning the charger*

- Clean the exterior of the charger gently with a cloth or soft brush.
- If necessary, use a mild soap solution for the external removal of coarser soiling.

**IMPORTANT:** Dampen the cloth only slightly or wring it out well to prevent liquid from penetrating the inside of the housing and the connections. If liquid enters the interior of the housing or the connections, the charger may be damaged and electrical safety may be impaired.

- Wipe all surfaces dry after cleaning.

---

\* This applies only if your e-bike is equipped with a removable battery (See Chapter 23 "Function and model variants of the battery").





**Fazua GmbH**  
Marie-Curie-Straße 6  
85521 Ottobrunn, Germany  
[www.fazua.com](http://www.fazua.com)

Dok.ref.: FAZUA RIDE 60 | Original instructions | 20220323

**FAZUA**