

**SRAM**

2019

Road Components

**SRAM**  
**RED** 

**SRAM**  
**RED** 

**SRAM**  
**RED** 

**SRAM**  
**FORCE** 

**SRAM**  
**FORCE** 

**SRAM**  
**FORCE1** 

**SRAM**  
**RIVAL** 

**SRAM**  
**RIVAL1** 

**SRAM**  
**APEX** 

**SRAM**  
**APEX1** 

**S-Series**



FRAME FIT SPECIFICATIONS

**General Notes**

All dimensions are in millimeters unless otherwise noted.

Images in this document are not to scale.

Your product's appearance may vary slightly from the images in this document.

Information in this document is subject to change without prior notice.

If you have any questions please contact your SRAM representative.

# Table of Contents

## Electronic Shifters

---

<b>BlipBox</b> Dimensions without Elastic Band.....7	<b>Blips</b> Remote Shift Buttons and Connector Dimensions.....10	<b>Clics</b> Extension Shift Buttons.....12
<b>BlipBox</b> Dimensions with Elastic Band ..... 8	<b>BlipClamp and BlipGrip</b> Remote Shifter Mounting.....11	<b>Shift-Brake Levers</b> Remote Shifter Connections .....13
<b>BlipBox</b> Enclosure Guidelines..... 9		

## Front Derailleurs

---

<b>Front Derailleur Clearance</b> SRAM 12 Speed.....15	<b>Frame Chainstay Information</b> SRAM 10 and 11 Speed .....19	<b>Braze-on Hanger Dimensions</b> Front Derailleur Interface..... 23
<b>Front Derailleur Clearance</b> SRAM 11 Speed.....16	<b>Braze-on Hanger Dimensions</b> SRAM 12 Speed.....20	<b>Clamp-on Front Derailleur Mount Dimensions</b> Front Derailleur Interface..... 24
<b>Front Derailleur Clearance</b> SRAM 11 Speed.....17	<b>Braze-on Hanger Dimensions</b> SRAM 10 and 11 Speed .....21	<b>Front Derailleur Position with Clamp Adapter</b> SRAM 12 Speed.....25
<b>Frame Chainstay Information</b> SRAM 12 Speed.....18	<b>Braze-on Hanger Dimensions</b> Front Derailleur Interface.....22	<b>Front Derailleur Position with Clamp Adapter</b> SRAM 10 and 11 Speed .....26

## Rear Derailleurs

---

<b>Hanger and Chainstay Specifications</b> All SRAM Road Rear Derailleurs.....28	<b>Hanger Specifications</b> All SRAM Road Rear Derailleurs.....30	<b>Frame Rear Dropout Clearance</b> 12 Speed Road Chain and Cassette.....31
<b>Rear Derailleur Frame Clearance</b> All SRAM Road Rear Derailleurs.....29		

## Road Cranksets

---

<b>Crankarm and Chainring Frame Clearance</b> 12 Speed..... 33	<b>Crankset Frame Clearance</b> 11 Speed..... 38	<b>Spider Frame Clearance</b> Quarq DZero Platform Power Meters..... 41
<b>Crankarm and Chainring Frame Clearance</b> 12 Speed..... 34	<b>Crankset Frame Clearance</b> 11 Speed and Singlespeed ..... 39	<b>Spider Frame Clearance</b> Quarq AXS Platform Power Meters ..... 42
<b>Crankset Frame Clearance</b> 11 Speed..... 37	<b>Crankset Frame Clearance</b> 8/9/10 Speed..... 40	

## Bottom Bracket Shell Specifications

---

<b>BSA and Italian Bottom Bracket</b> Road Bottom Bracket Frame Shell Specification ..... 44	<b>PressFit 30</b> Road Bottom Bracket Frame Shell Specification ..... 46	<b>BB30</b> Information..... 48
<b>T47 85.5</b> Road Bottom Bracket Frame Shell Specification ..... 45	<b>PressFit Road 86.5</b> Road Symmetric Frame Shell Specification ..... 47	

## DUB Bottom Brackets

---

<b>DUB BSA 68</b> Bottom Bracket Specification..... 50	<b>DUB PressFit 30 79-A</b> Bottom Bracket Specification..... 54	<b>DUB BB30</b> Bottom Bracket Specification..... 58
<b>DUB T47 85.5</b> Bottom Bracket Specification..... 51	<b>DUB PressFit 30 83-A</b> Bottom Bracket Specification..... 55	<b>DUB BB30 73-A</b> Bottom Bracket Specification..... 59
<b>DUB PressFit 30</b> Bottom Bracket Specification..... 52	<b>DUB PressFit 86.5</b> Bottom Bracket Specification..... 56	<b>DUB BB30 83-A</b> Bottom Bracket Specification..... 60
<b>DUB PressFit 30 73-A</b> Bottom Bracket Specification..... 53	<b>DUB BB386</b> Bottom Bracket Specification..... 57	

## Brakes

---

### Safety Guidelines for Rotor Size and Brake Pad Material

All SRAM Road Hydraulic Disc Brakes... 62

### SRAM Force eTap AXS

Disc Brake Hose Length Specification . 63

### SRAM RED eTap AXS

Disc Brake Hose Length Specification .. 64

### S-900 Aero HRD

Disc Brake Hose Routing Specification . 65

### Flat Mount Fork Specification

All SRAM Flat Mount Calipers ..... 66-68

### Post Mount Fork Specification

All SRAM Post Mount Calipers..... 69-70

### SRAM CenterLine XR

Two-piece Center Locking Rotor Dims... 71

### SRAM CenterLine X

Two-piece Center Locking Rotor Dims.. 72

### SRAM CenterLine

One-Piece Center Locking Rotor Dims.. 73

### SRAM CenterLine XR

Two-piece 6-Bolt Rotor Dims ..... 74

### SRAM CenterLine X

Two-piece 6-Bolt Rotor Dims ..... 75

### SRAM CenterLine

One-piece 6-Bolt Rotor Dims ..... 76

### Spoke Clearance

Road Disc Brakes..... 77

### Dropbar Guidelines

Road Electronic Shift-Brake..... 78

### S-900 Aero HRD

Hydraulic Aero Brake Lever Bar ..... 79

### BB7/ BB5 Road

Mechanical Disc Brake Clearance ..... 80

### Front Rim Brake Caliper

Direct Mount and Single Pivot Design  
Dimensions..... 81

### Rear Rim Brake Caliper

Direct Mount and Single Pivot Design  
Dimensions..... 82

### Front Direct Mount

Mounting Dimensions..... 83

### Rear Direct Mount

Mounting Dimensions..... 84

### Direct Mount

Rim Brake Caliper Design Dims..... 85

### Single-Post Mount

Rim Brake Caliper Design Dims..... 86

### Shorty Ultimate

Dual Mounted Brake Caliper ..... 87

### Shorty 6/ Shorty 4

Cable Carrier and Straddle Cable..... 88

## Wheels and Hubs

---

### Zipp Wheels

Rim/Disc Design Parameters ..... 90

### Rear Derailleur Wheel Spoke Clearance

XDR..... 91

### Driver and Wheel Standard

10 and 11 speed ..... 92-93

### Zipp Hubs with Center Locking Disc Brake Mount

Front Hub Specifications ..... 94

Rear Hub Specifications ..... 95

Front and Rear Hub Distance to Rotor... 96

### Zipp Hubs with ISO 6 Bolt Disc Brake Mount

Front Hub Specifications ..... 97

Rear Hub Specifications ..... 98

### Zipp Rim Brake Hubs

Front Hub Specifications ..... 99

Rear Hub Specifications ..... 100

### Maxle Description Decoder

#### Maxle Ultimate

Frame / Fork Clearance ..... 102

#### Maxle Stealth

..... 103

### Maxle Lite & Maxle

Frame / Fork Clearance ..... 104

### Maxle, Maxle Lite, Maxle Ultimate, Maxle Stealth

Rear Frame Specification ..... 105

Fork Specification..... 106

Fork Specification..... 107

# Electronic Shifters

# BlipBox

## Dimensions without Elastic Band

Custom Mounting without the Elastic Band Mounting Adapter

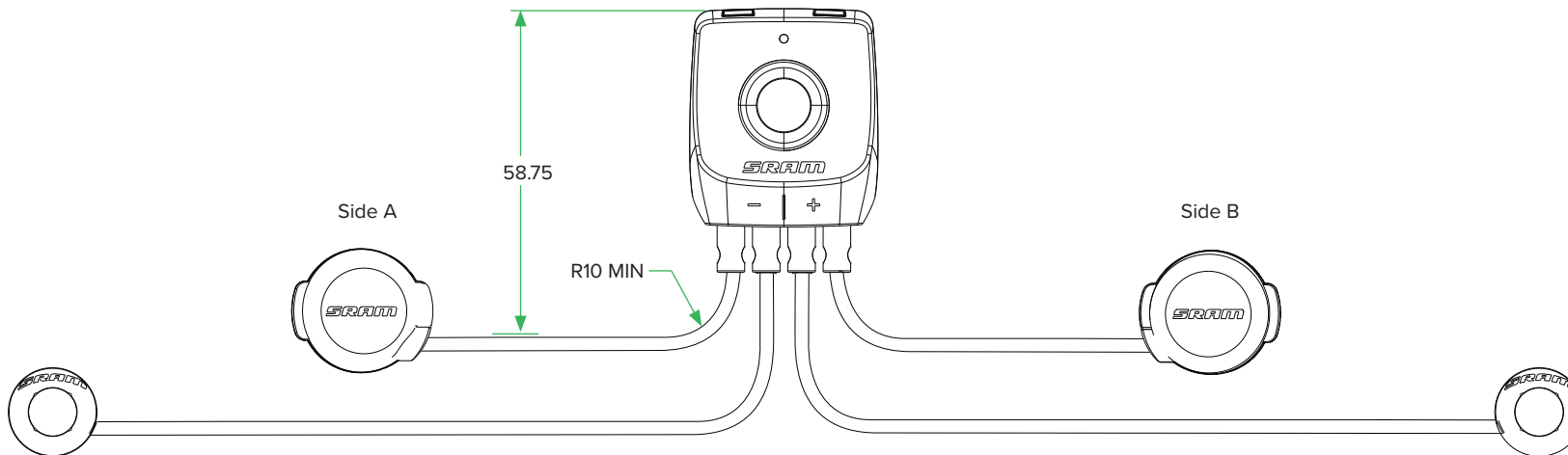
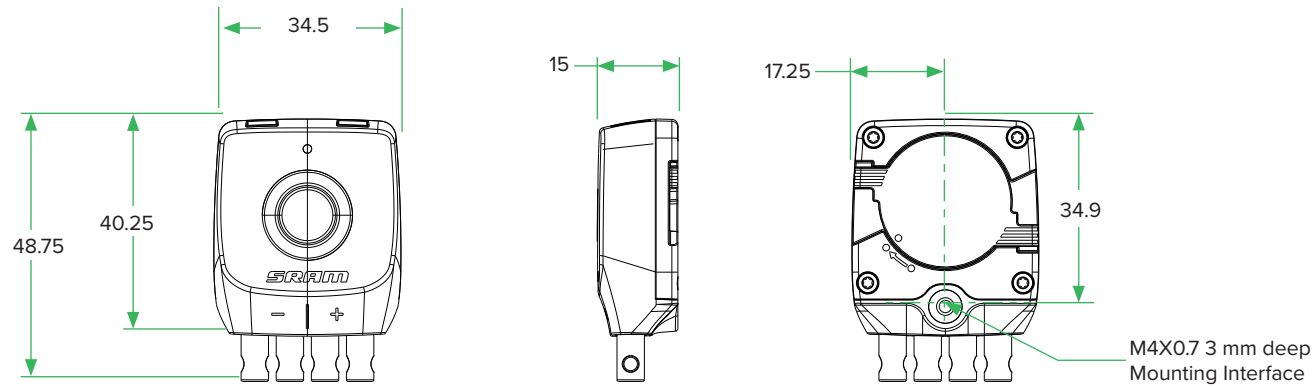

# BlipBox

## Dimensions with Elastic Band

Elastic Band Mounting Adapter for Mounting to Cylindrical or Flat Surfaces

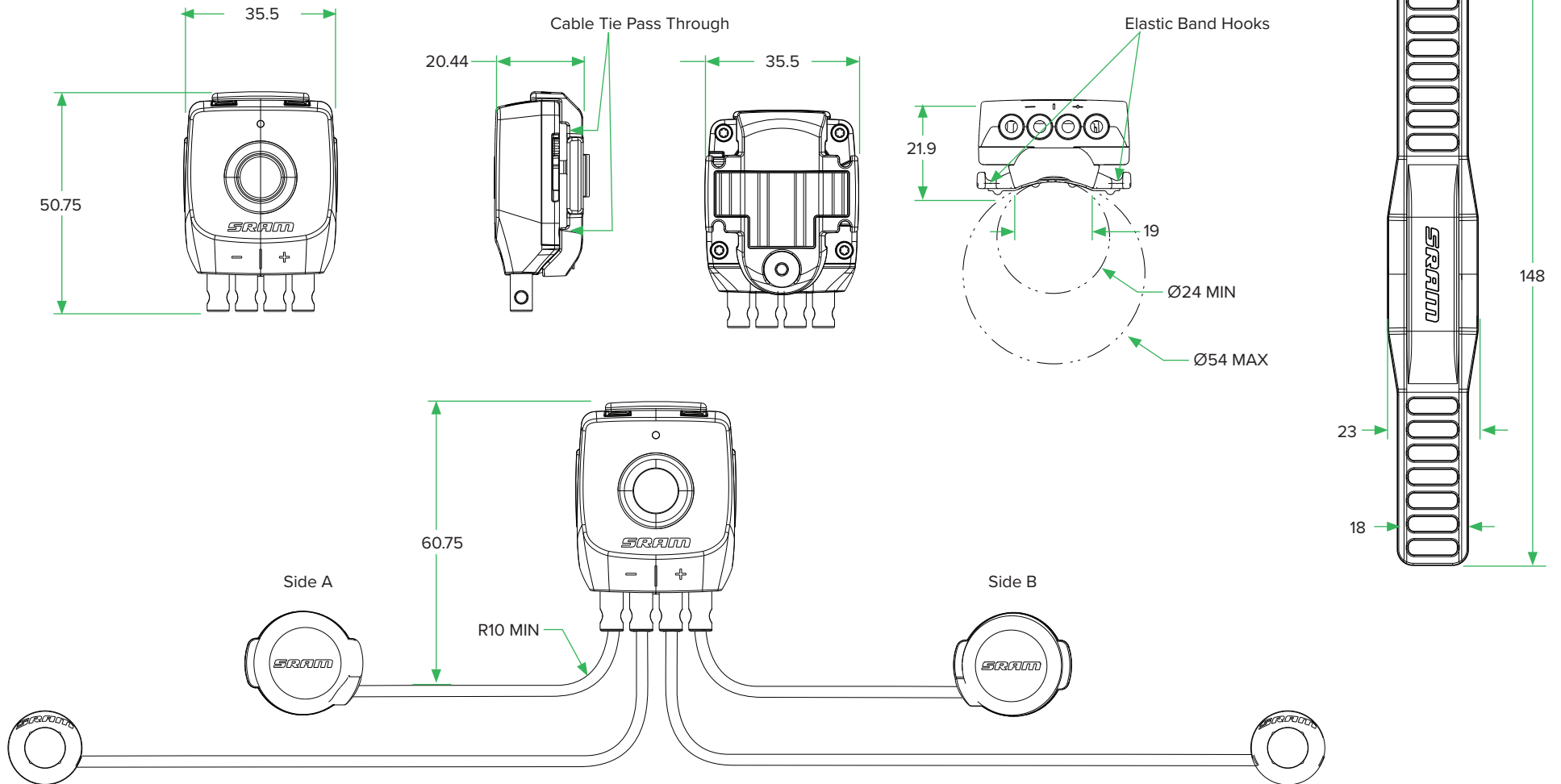



# BlipBox

## Enclosure Guidelines

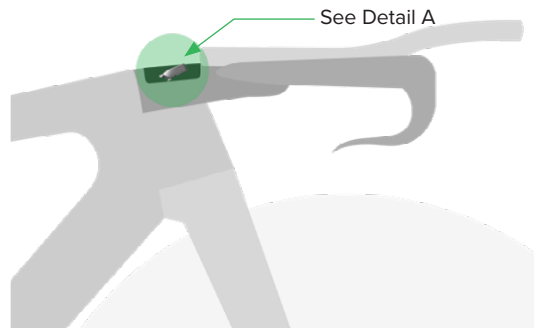

BlipBox orientation for optimal performance in internal enclosure space:

- 1 Must be mounted within  $\pm 25^\circ$  from the horizontal plane.
- 2 The button can face upward or downward.
- 3 The wire input ports can face forward or backward.
- 4 The enclosure should not be 3 or more sides of the following materials: carbon, carbon plastic, metal, or water-filled reservoir.

Detail A: Enclosure Guidelines and Mounting Angle

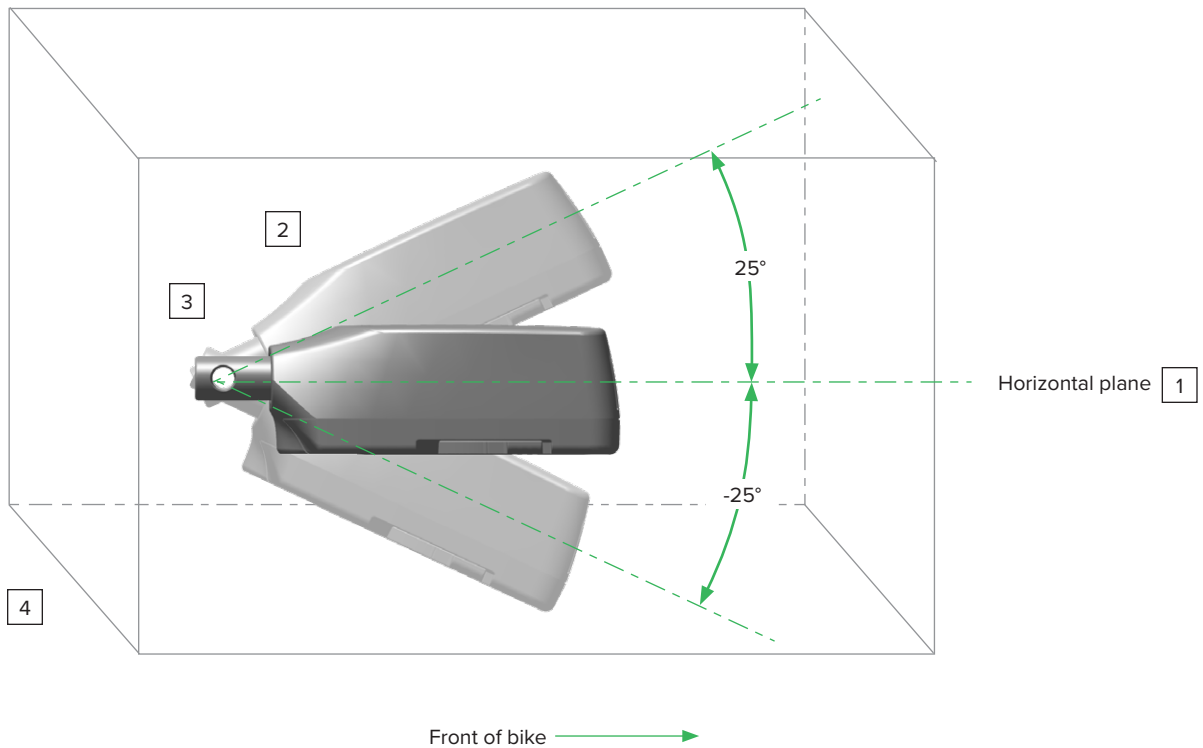

# Blips

## Remote Shift Buttons and Connector Dimensions

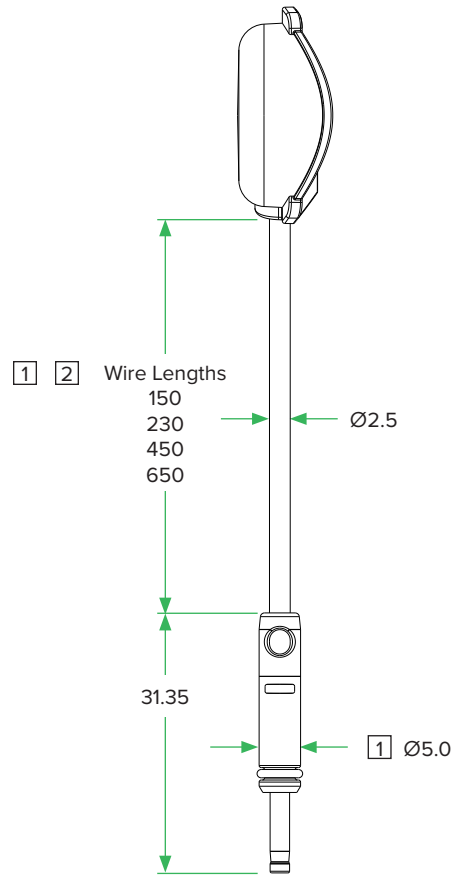

Left Shift Button

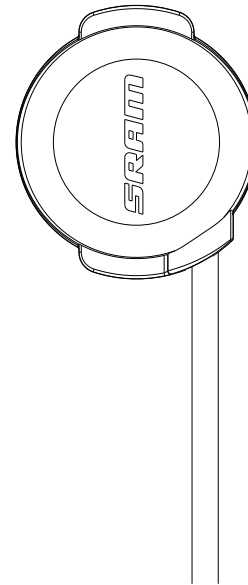

Right Shift Button

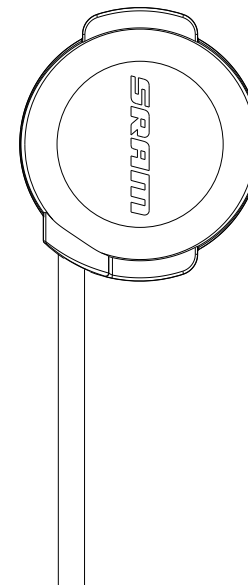

- 1 Consider the connector diameter and wire length when routing wires internally.
- 2 Choose the wire lengths based on application and desired location of the Blips.

# BlipClamp and BlipGrip

## Remote Shifter Mounting

31.8 mm Bar

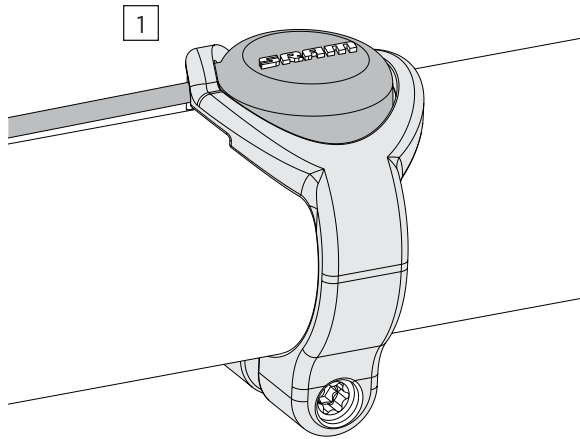

22.2-35 mm Bar

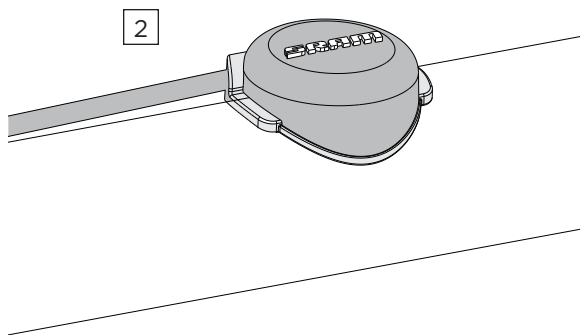

22.2mm TT Extensions

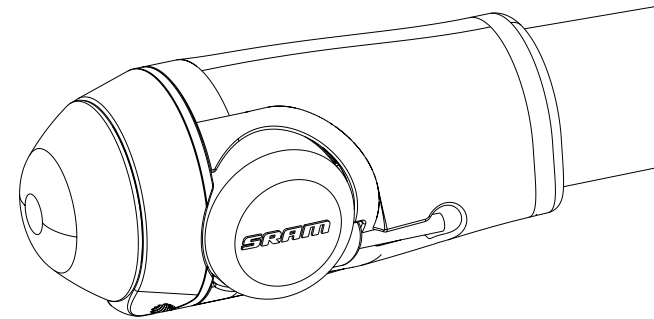

- 1 Button holder designed for 31.8 mm bar mounting.
- 2 Direct mount under the handlebar tape for 22.2 mm through 35 mm diameter bars.

# Clics

## Extension Shift Buttons

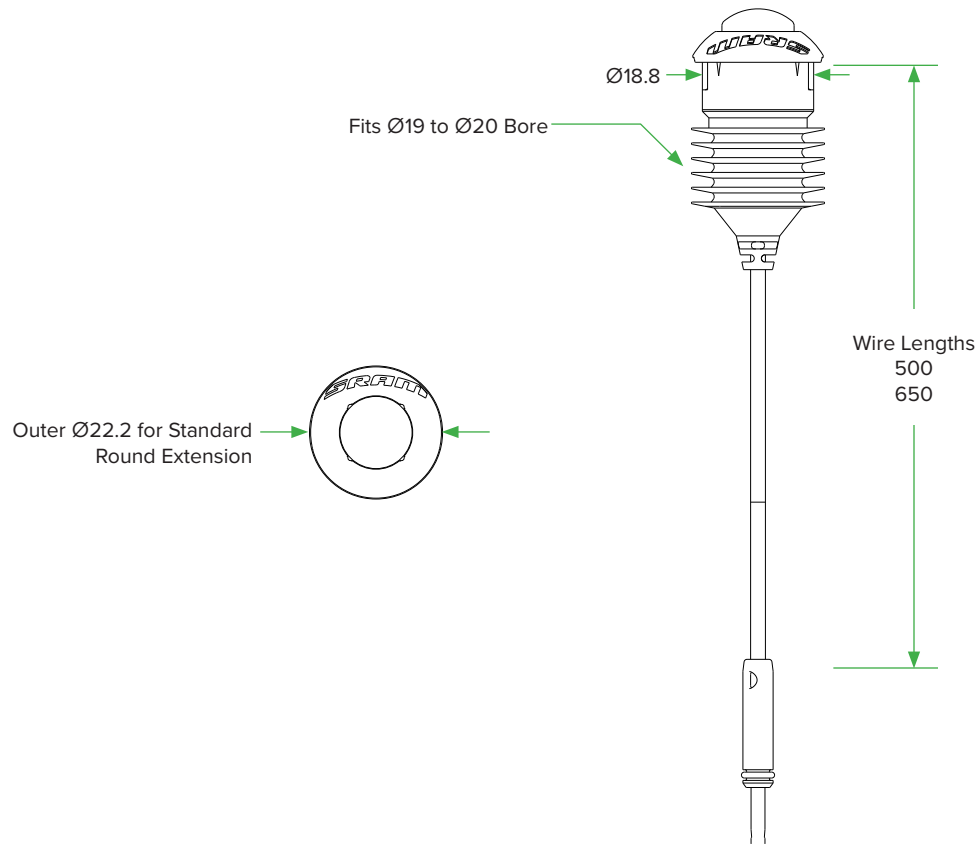

- 1 Internally mounted shifter setup requires the Blip or Clic wires to be routed external of bar, stem, and frame materials a minimum total of 100 mm per side for all the wires. Routing under bar tape is acceptable within the 100 mm length.

# Shift-Brake Levers

## Remote Shifter Connections

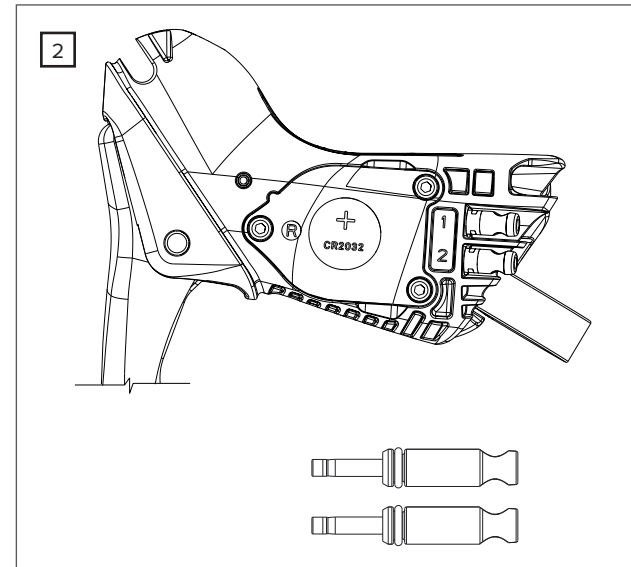
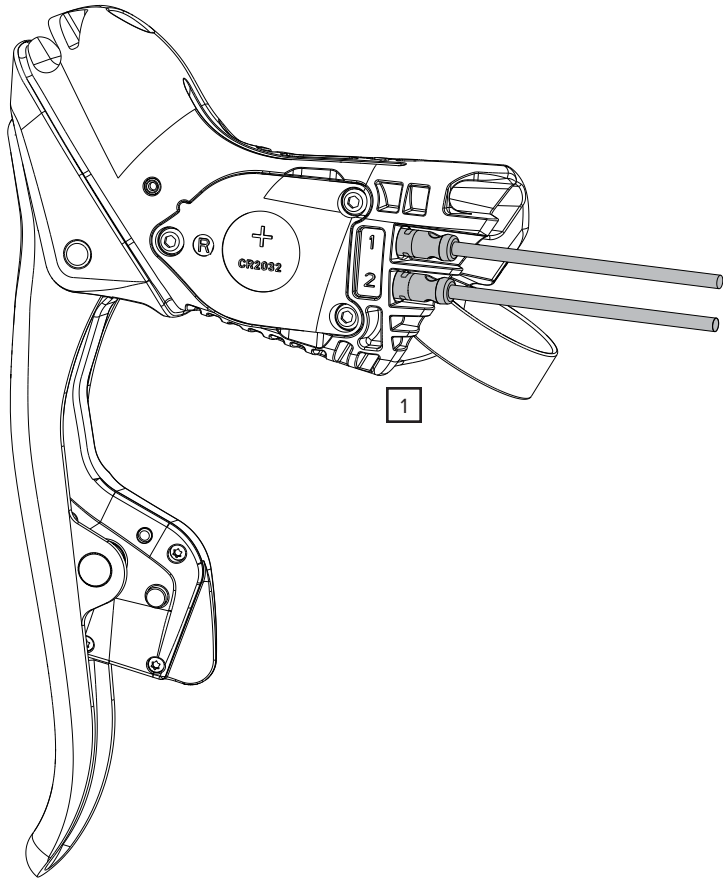

- 1 The left and right shifter brake each provide additional ports for auxiliary remote shifter buttons. SRAM Red eTap AXS has two ports, and SRAM Force eTap AXS had one port.
- 2 Use plugs when remote shifters are not in use.
- 3 Provide a small amount of slack in the wire for shifter brake repositioning.
- 4 Route the wires underneath the bar tape.

# Front Derailleurs

# Front Derailleur Clearance

SRAM 12 Speed

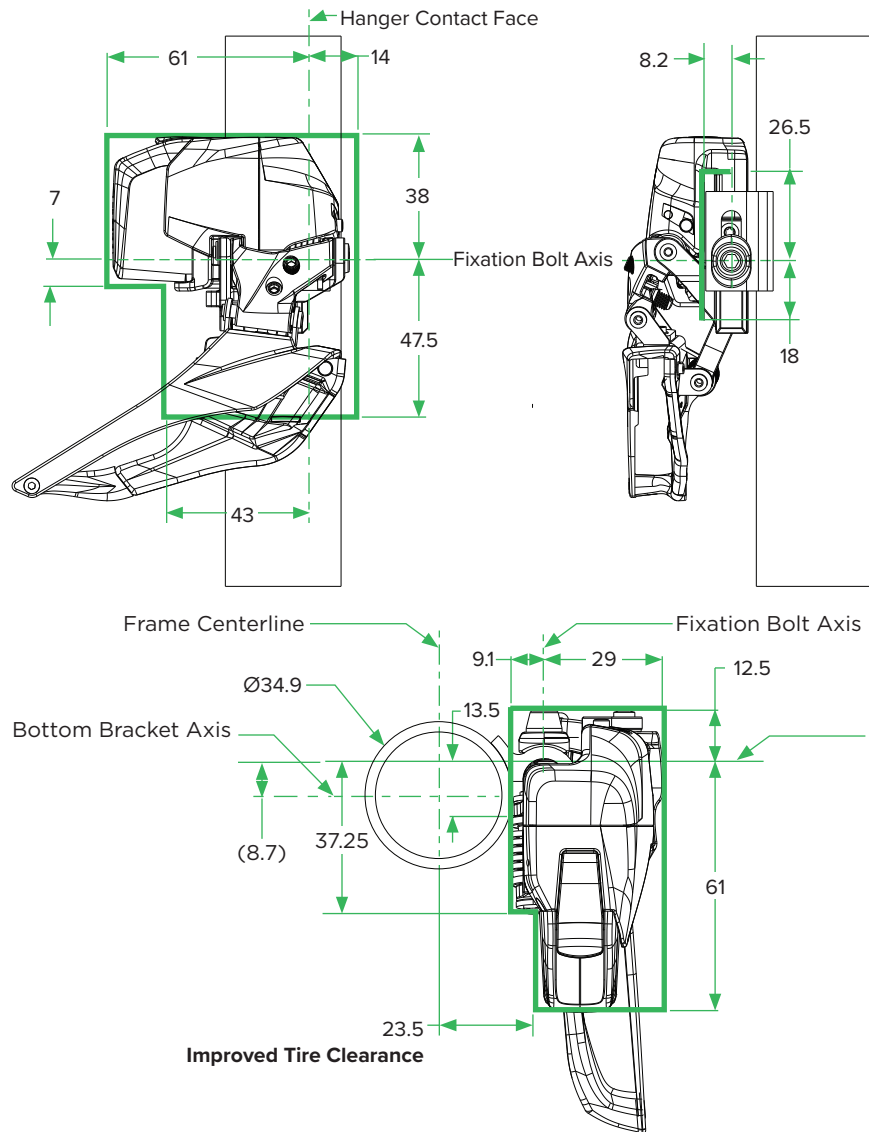

Front Derailleur in Low Gear

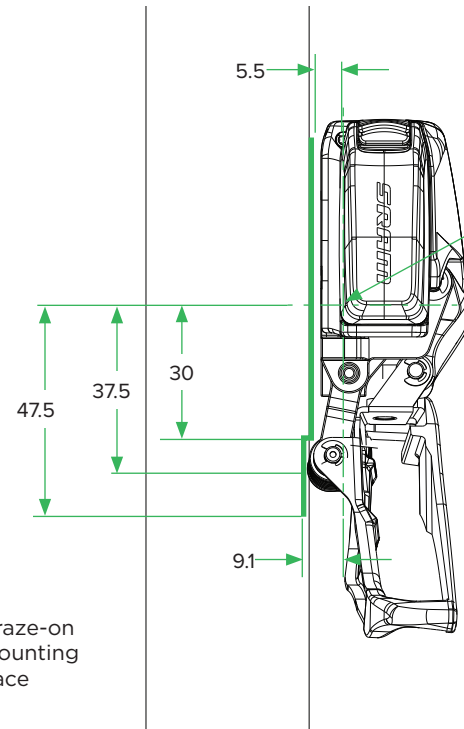

Front Derailleur in High Gear

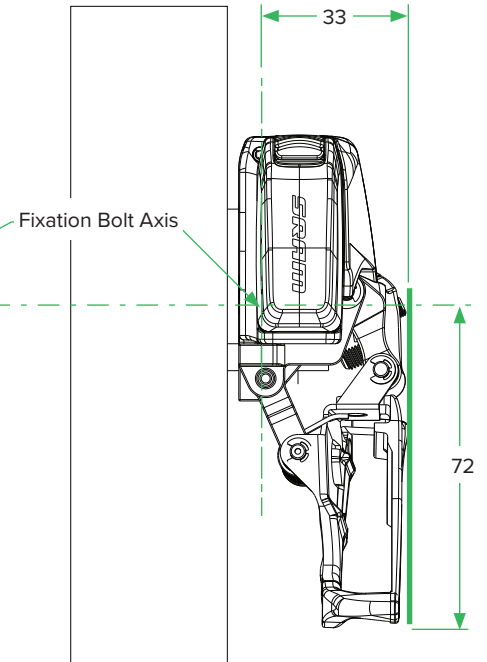

# Front Derailleur Clearance

SRAM 11 Speed

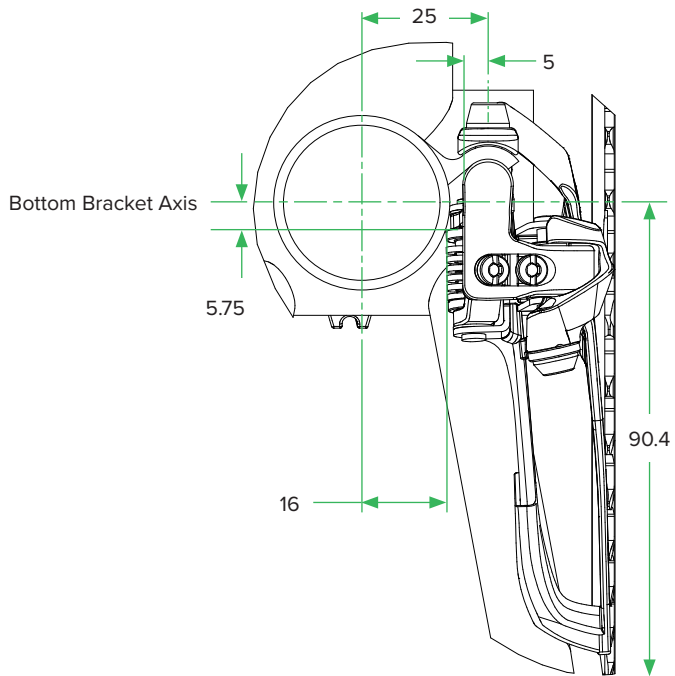

Front Derailleur in Low Gear

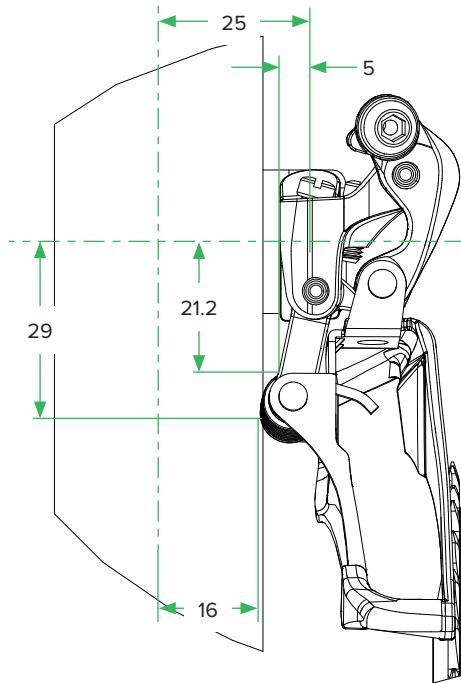

Front Derailleur in High Gear

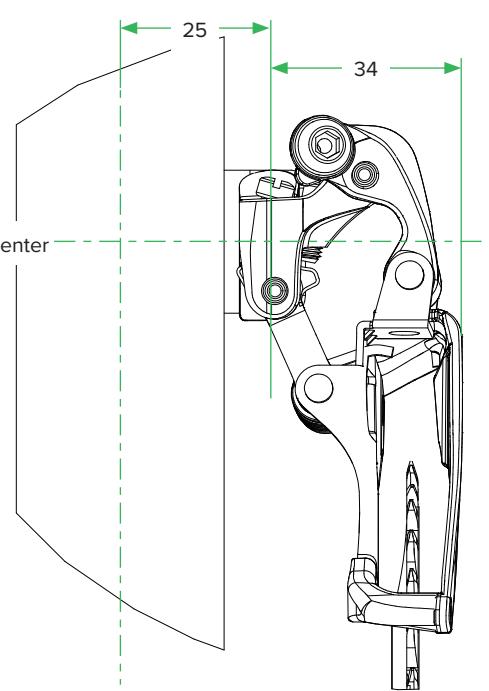



# Front Derailleur Clearance

SRAM 11 Speed

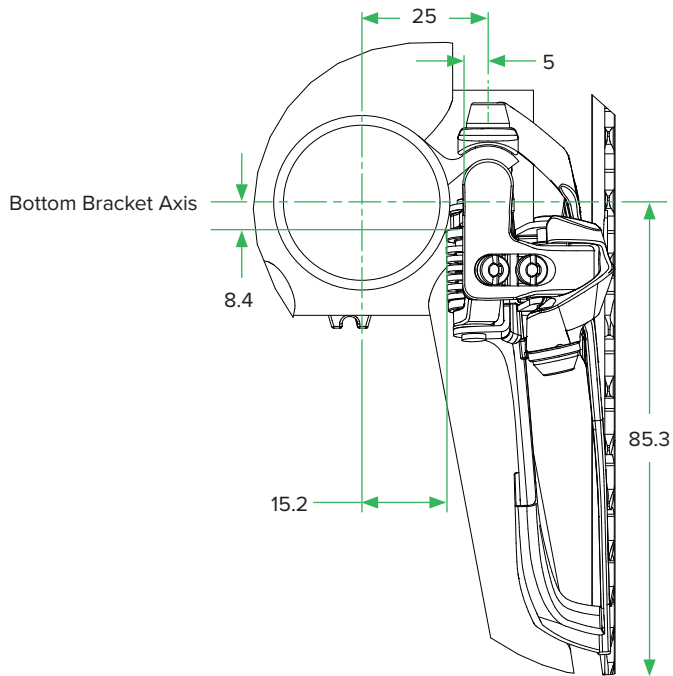

Front Derailleur in Low Gear

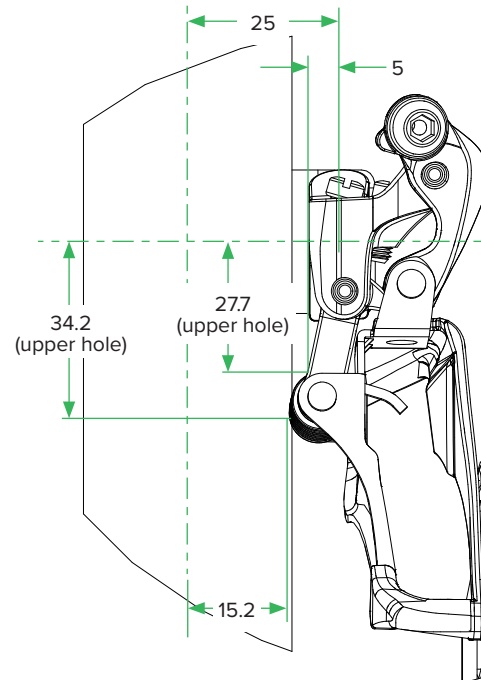

Front Derailleur in High Gear

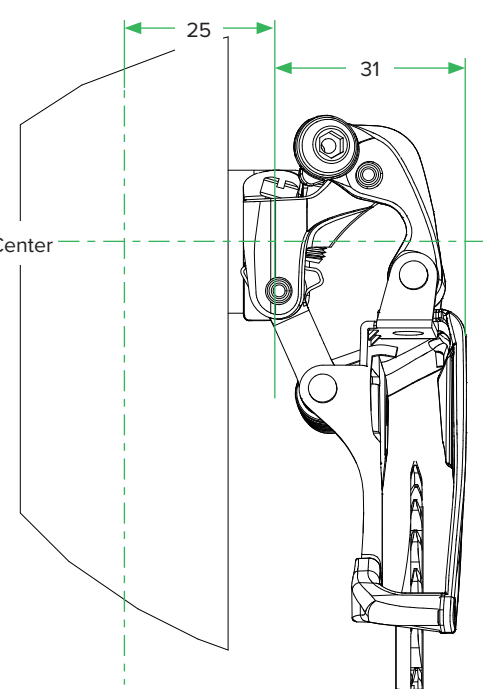

# Frame Chainstay Information

## SRAM 12 Speed

	Minimum Chainstay Length A (mm)	OLD* Hub Spacing (mm)
2x	405	130, 135, and 142
1x	395	

\* Over Locknut Dimensions

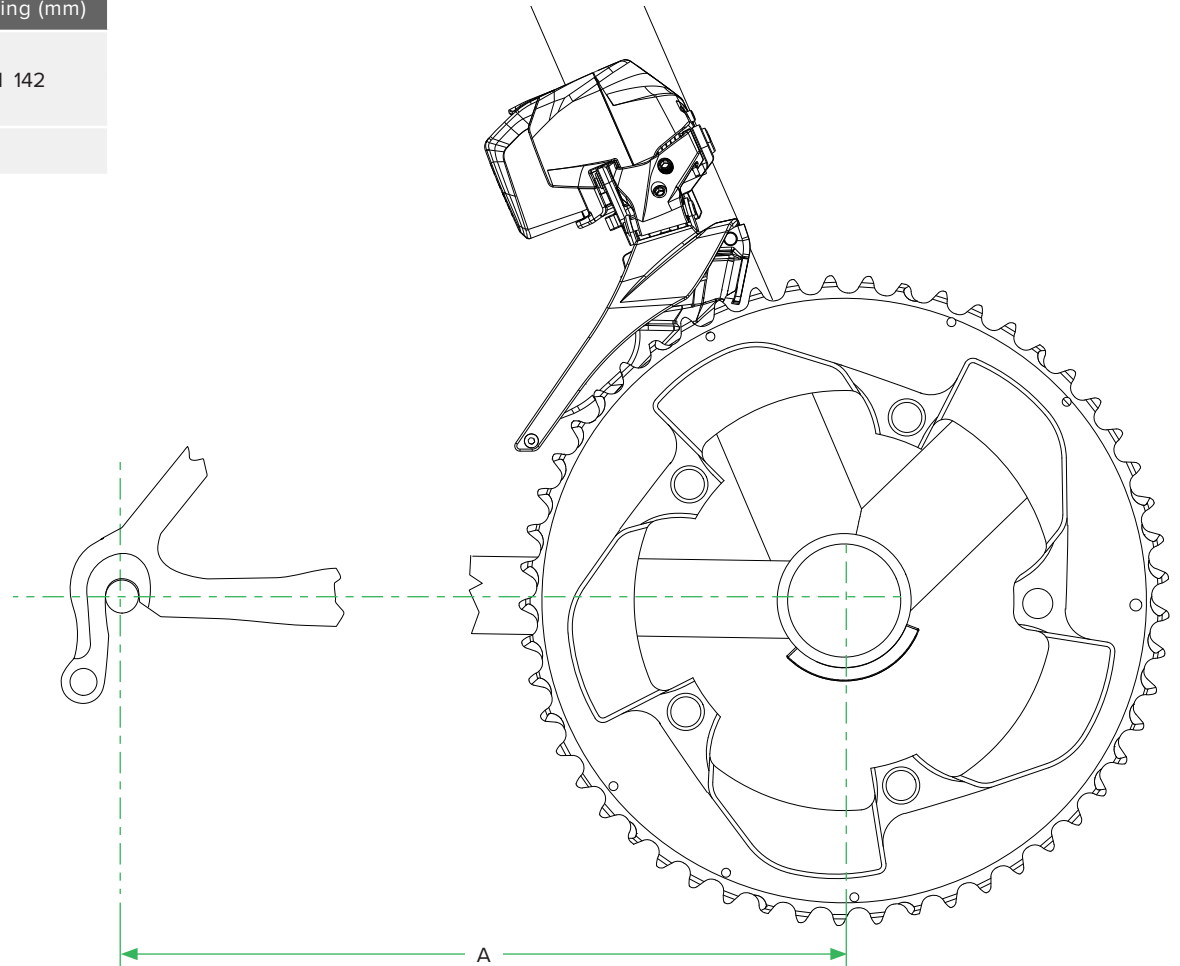

# Frame Chainstay Information

## SRAM 10 and 11 Speed

	Chainring	Minimum Chainstay Length A (mm)	
		130 OLD* frames 135 OLD frames w/ Wide Axle Cranks	135 OLD frames
2x11	55/42	405	430
	53/39		
	52/36		410
	50/34		405
	46/36		410
	46/34		405
2x10	55/42	395	430
	54/42		
	53/39	405	
	52/36		
	52/38		
	50/34		
	46/36		

\*Over Locknut Dimensions

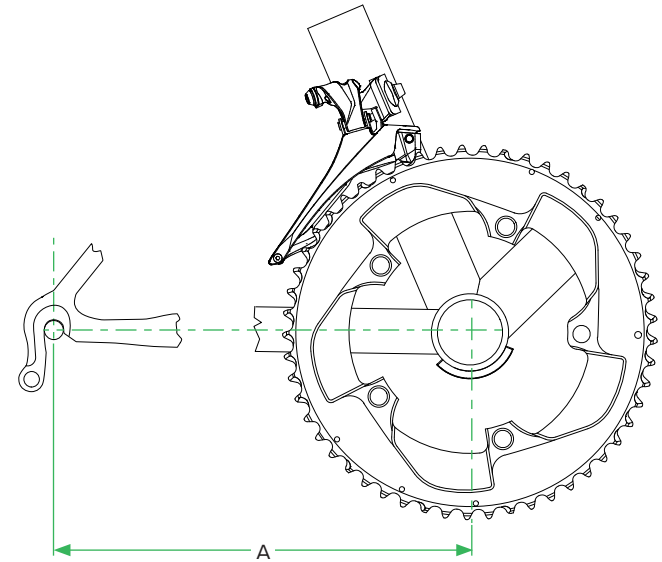

### Potential problems with not following the minimum chainstay length

#### ⚠ WARNING CRASH HAZARD

When the chain is on the big chainring and smallest rear cog, increased chain angle, increased chain angle can cause the chain to derail outboard off of the large chainring under very high pedaling loads, which may lead to a crash and serious injury and/or death to the rider.

#### ⚠ WARNING CRASH HAZARD

When the chain is on the small chainring and smallest rear cog, reduced clearance between the chain and large chainring upshift rivets can cause the chain to unintentionally catch on the upshift rivets, which may lead to loss of control of the bicycle.

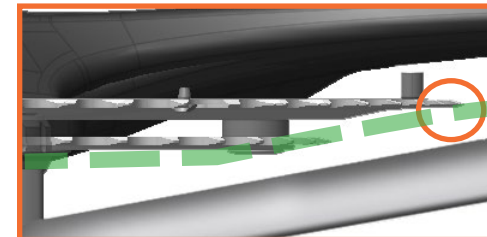

# Braze-on Hanger Dimensions

## SRAM 12 Speed

	Chainring Size	Fixation Bolt Height B (mm)
2x	50-37	150.5
	48-35	146.5
	46-33	142.5

Nominal FD position provided, design should allow for adequate adjustment range in the FD hanger slot to account for tolerances.

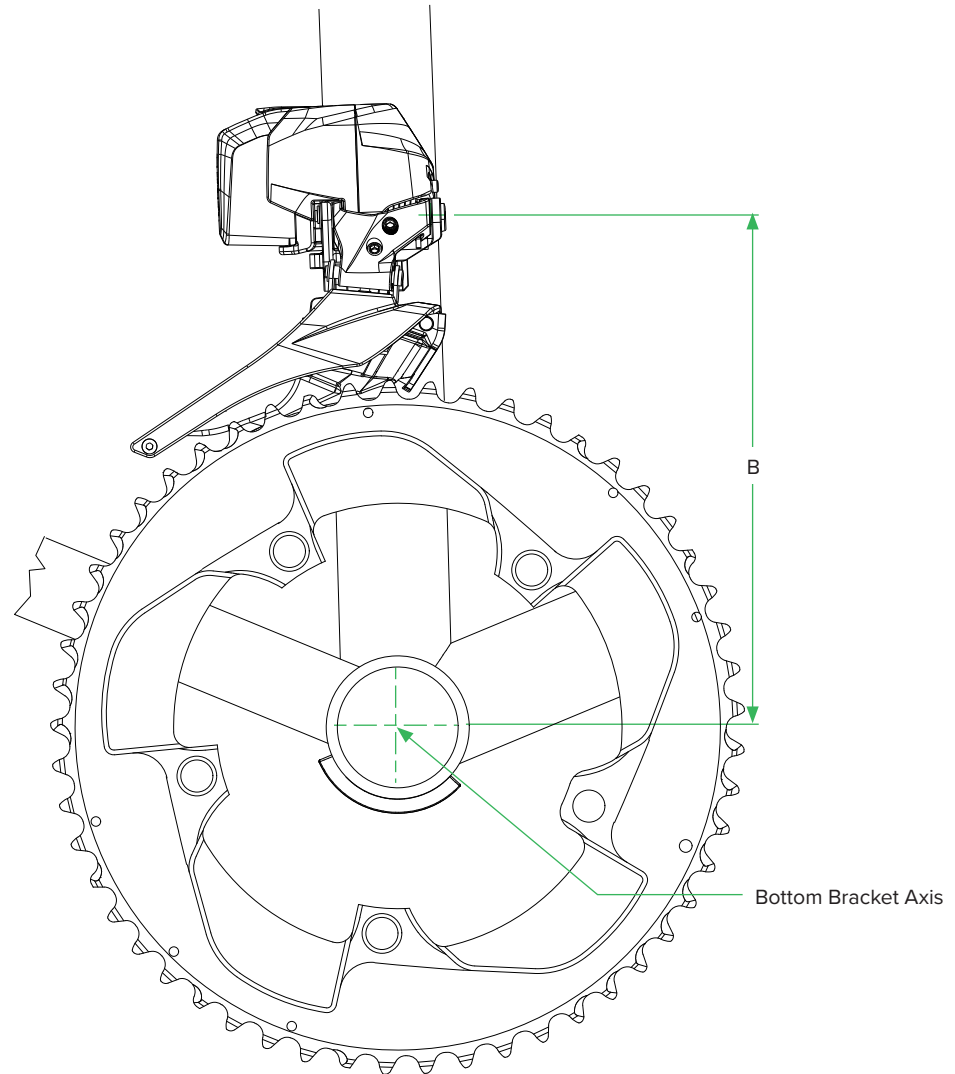

# Braze-on Hanger Dimensions

SRAM 10 and 11 Speed

	Chainring	Fixation Bolt Position
		B (mm)
2x11	55/42	151
	53/39	147
	52/36	145
	50/34	141
	46/36	133
2x10	55/42	154 (lower hole)
	54/42	152 (lower hole)
	53/39	150 (lower hole)
	52/36	148 (lower hole)
	52/38	148 (lower hole)
	50/34	152 (upper hole)
	46/36	144 (upper hole)

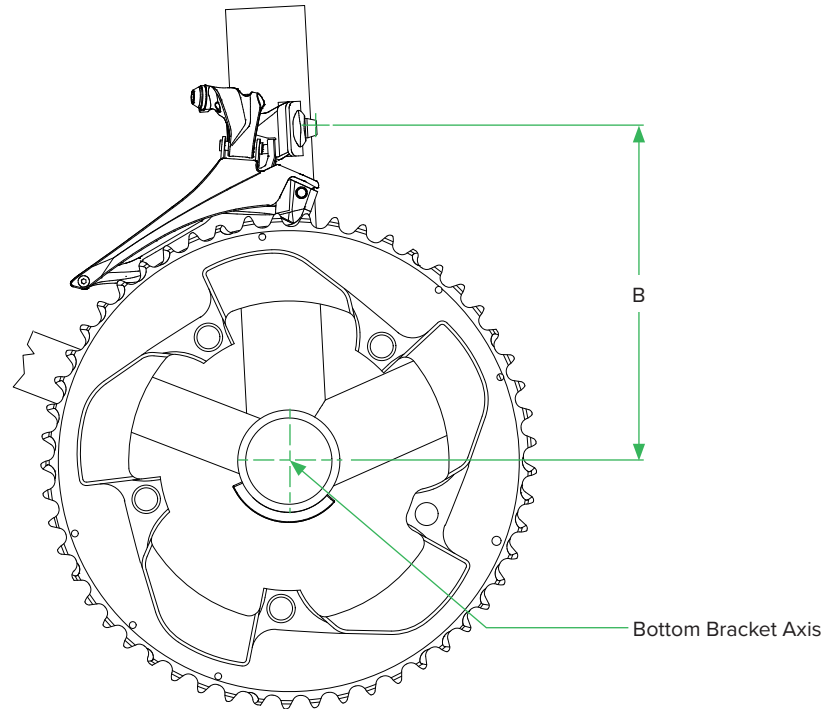

# Braze-on Hanger Dimensions

## Front Derailleur Interface

BB Shell Type	BB Shell Width* (mm)	BB Shell Offset to Left Side* (mm)	C (mm)	D (mm)
BSA/PressFit30/BB30	68	0	9	34
PF79-A	79	11	9	34
BB30-73A/PF30-73A	73	5	9	34
Italian	70	0	10	35
PressFit 86.5, BB386	86.5	0	18.25	43.25

\* Dimensions provided for reference, see BB Shell Specifications.

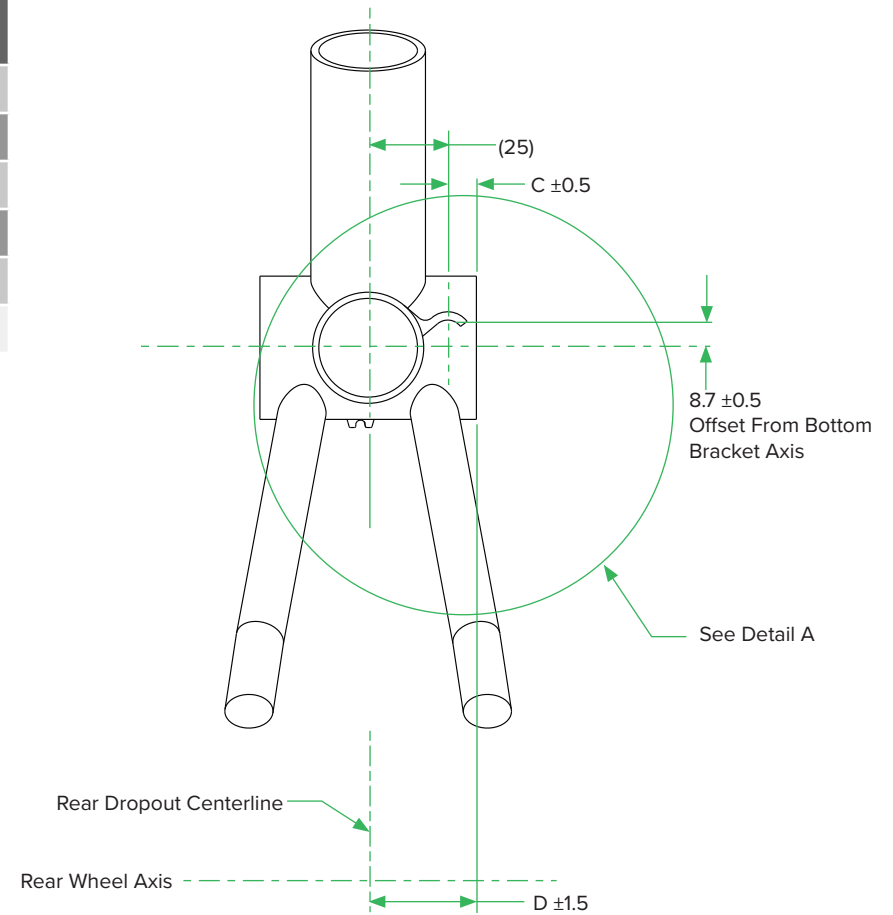
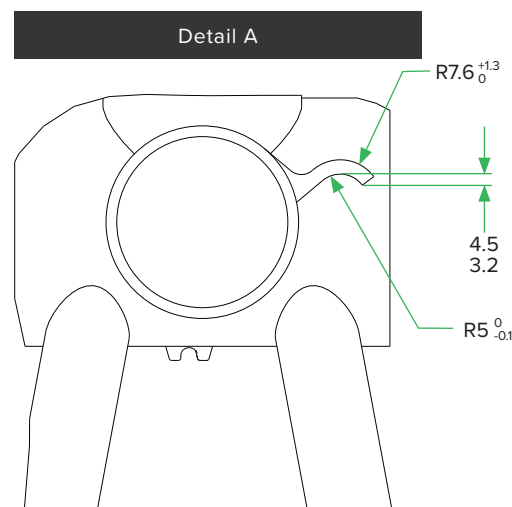

# Braze-on Hanger Dimensions

## Front Derailleur Interface

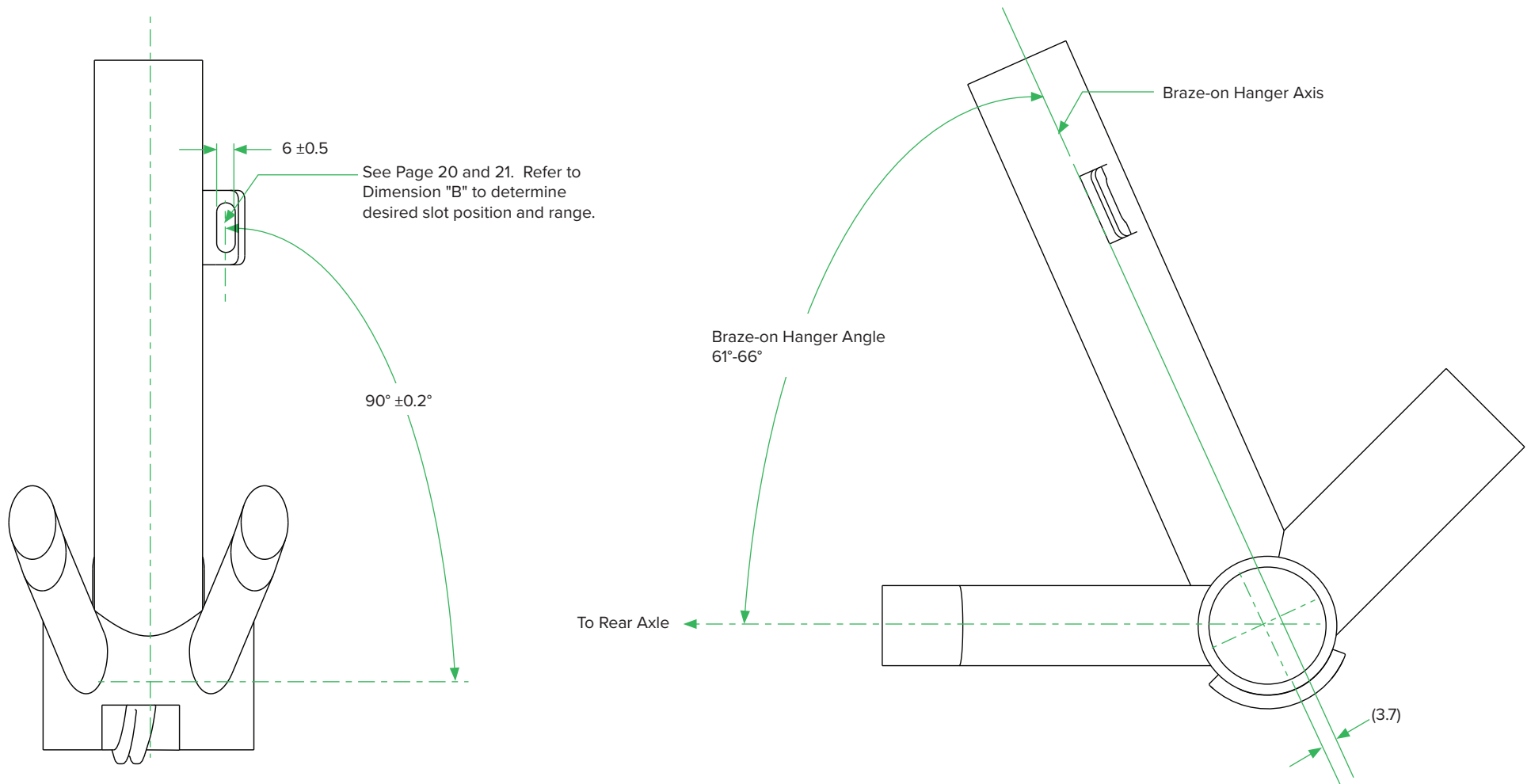

# Clamp-on Front Derailleur Mount Dimensions

## Front Derailleur Interface

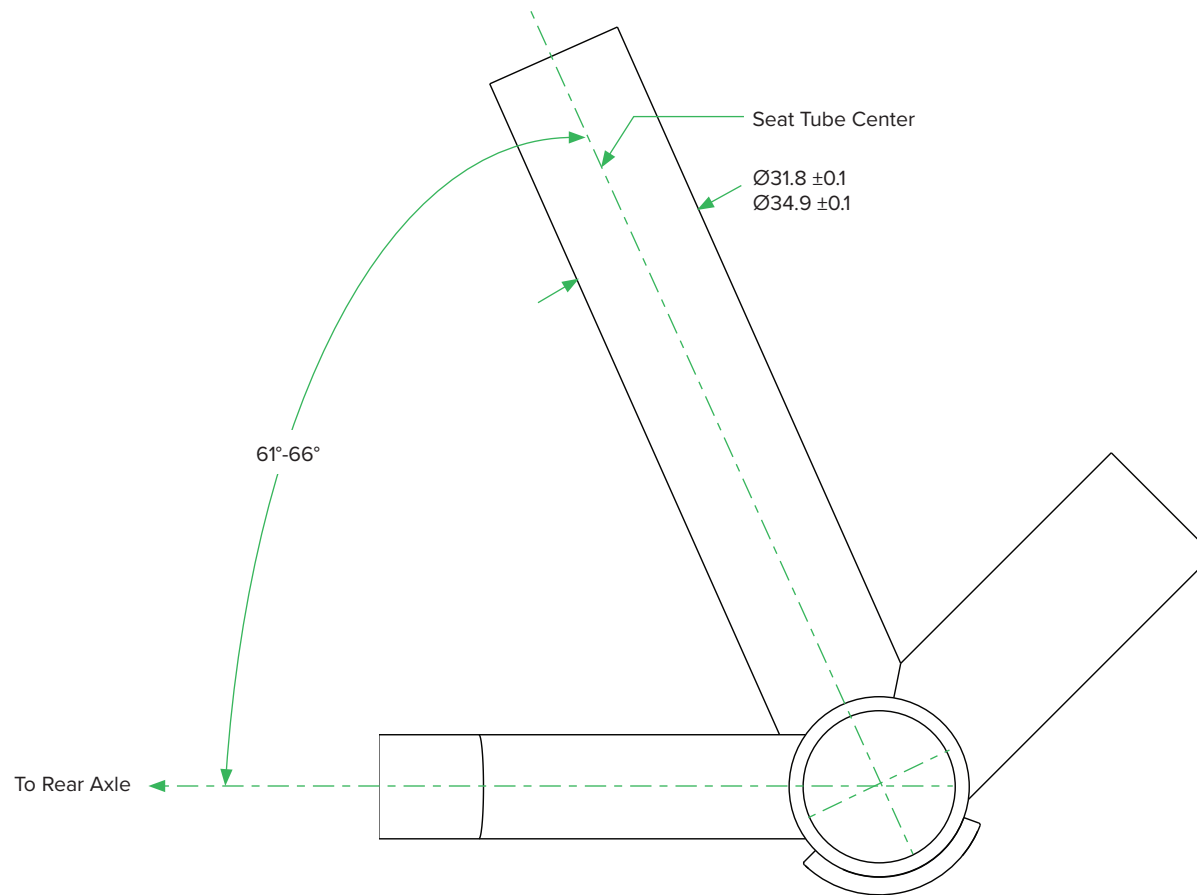



# Front Derailleur Position with Clamp Adapter

## SRAM 12 Speed

	Chainring Size	Clamp Height E (mm)
2x	50-37	135.5
	48-35	131.5
	46-33	127.5

Nominal FD position provided, design should allow for adequate adjustment range of the clamp along the seat tube to account for tolerances.

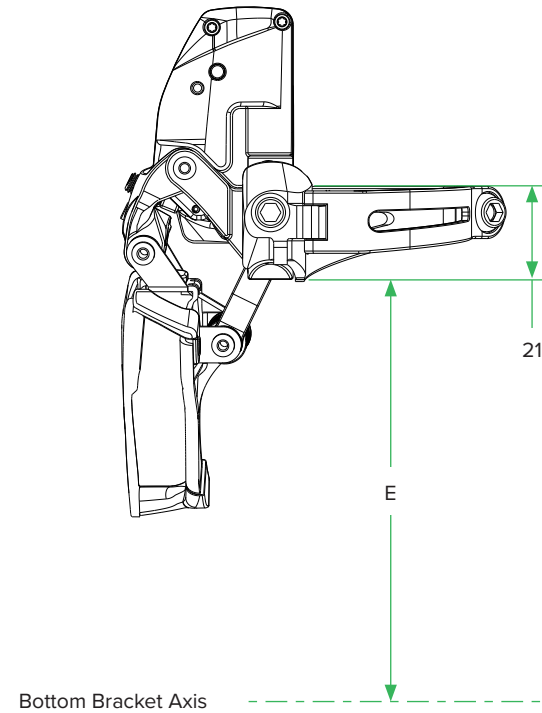

# Front Derailleur Position with Clamp Adapter

SRAM 10 and 11 Speed

	Chainring	Lower Clamp Position
		E (mm)
2x11	55/42	136
	53/39	132
	52/36	130
	50/34	126
	46/36	118
2x10	55/42	149
	54/42	147
	53/39	145
	52/36	143
	52/38	143
	50/34	139
	46/36	131

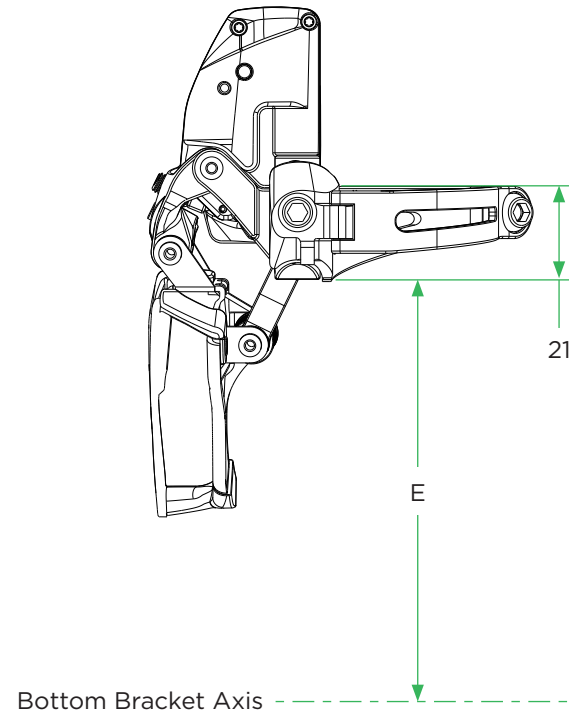

# Rear Derailleurs

# Hanger and Chainstay Specifications

## All SRAM Road Rear Derailleurs

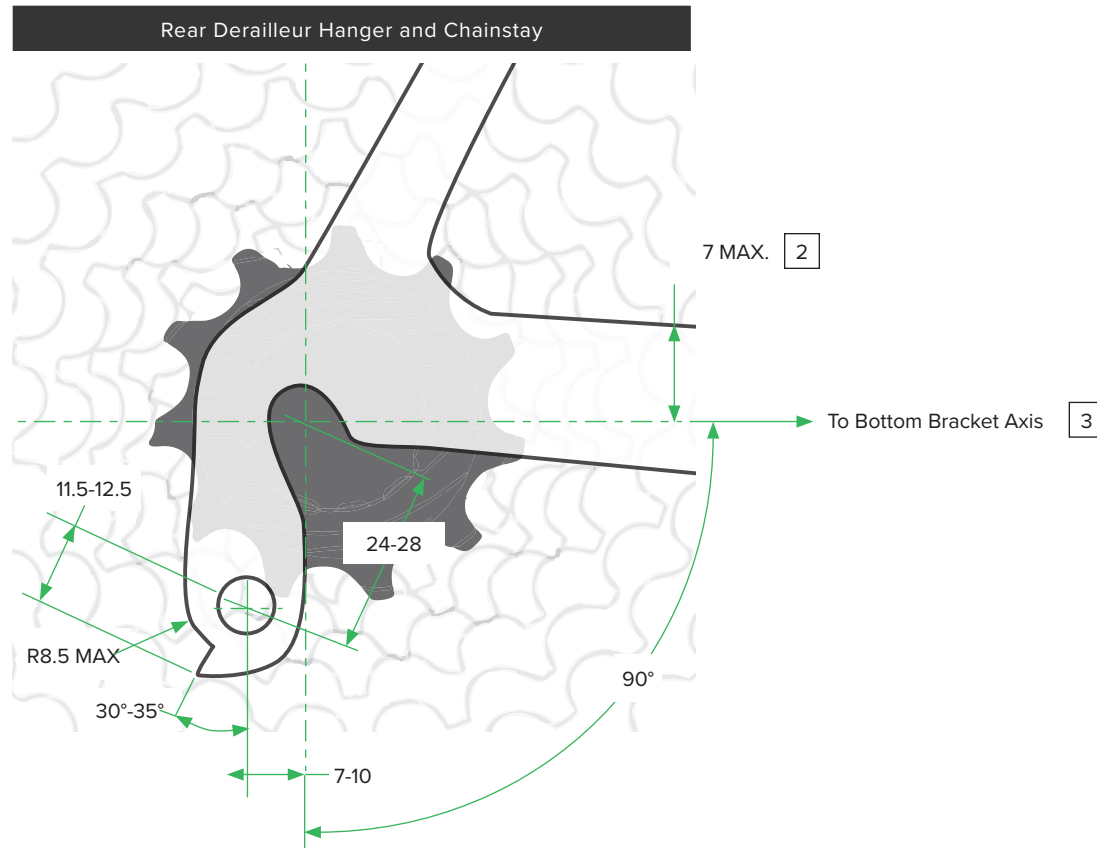

1 Chainstay should be designed for sufficient clearance to the chain when on the smallest cog to avoid contact between chain and chainstay when riding over a rough surface.

2 7 mm MAX applies where the chain crosses the chainstay while in the smallest cog and is an advisory to minimize the potential for chain contact with the chainstay during use.

3 Refer to the [Frame Chainstay Information](#) page for 1x and 2x chainstay length.

# Rear Derailleur Frame Clearance

All SRAM Road Rear Derailleurs

1 Keep this area clear for rear derailleur clearance.

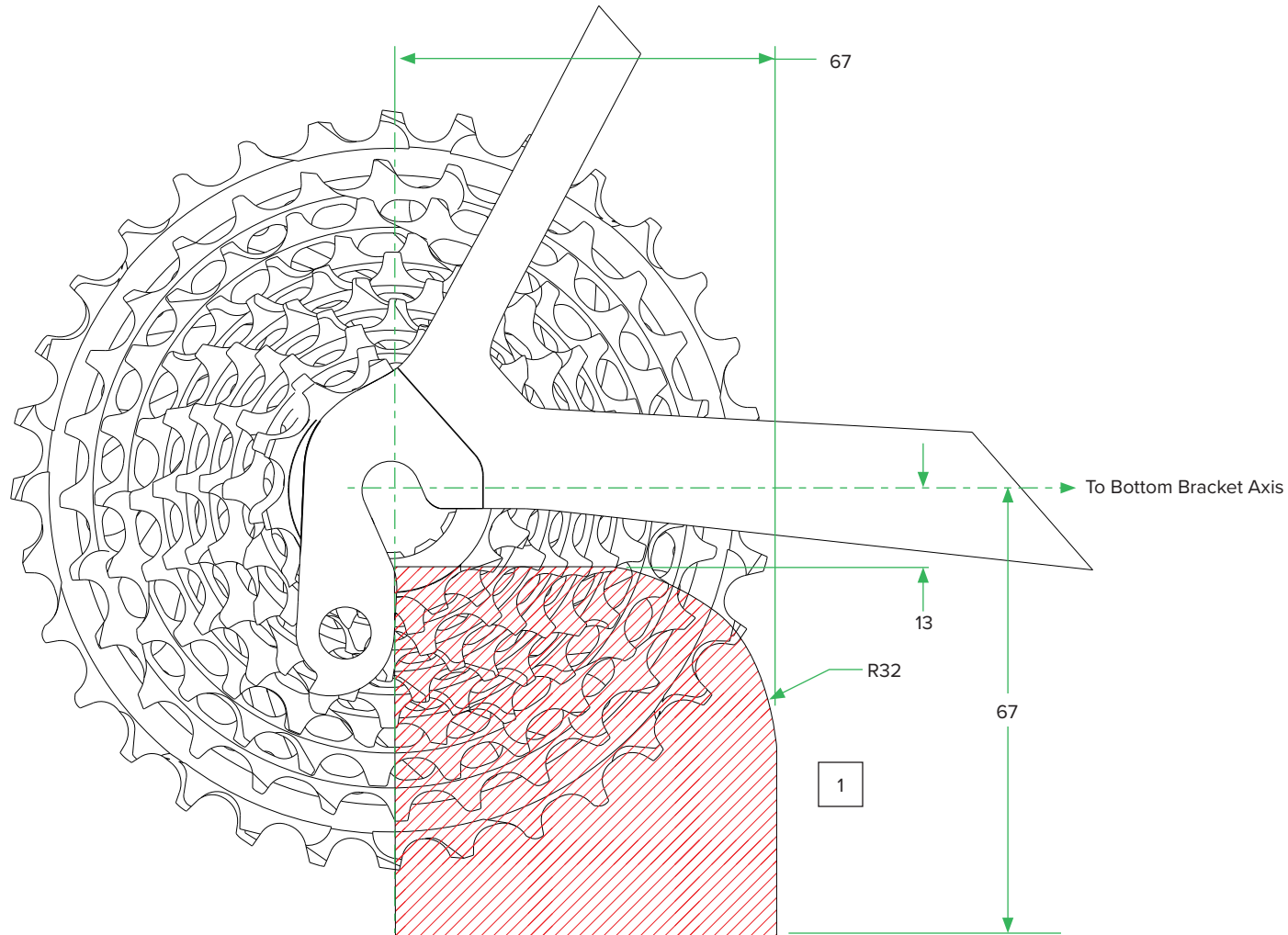

# Hanger Specifications

All SRAM Road Rear Derailleurs

	T (mm)
Quick Release	7-9
Thru Axle	3.5-5.5

## Quick Release

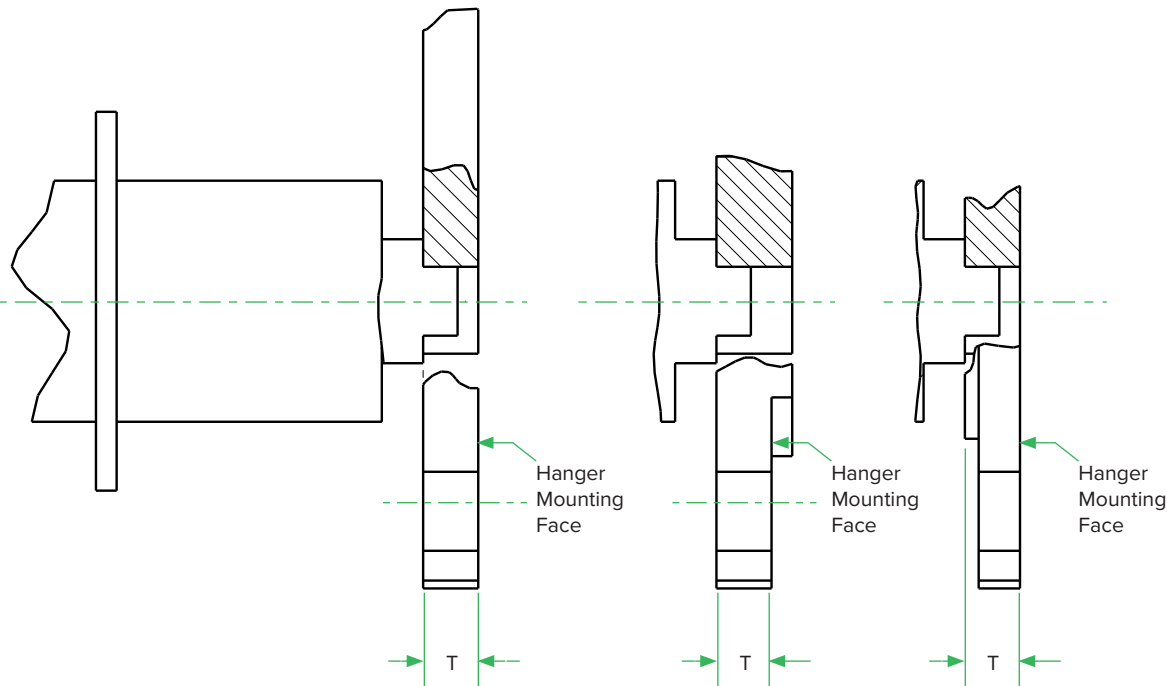

## Thru Axle

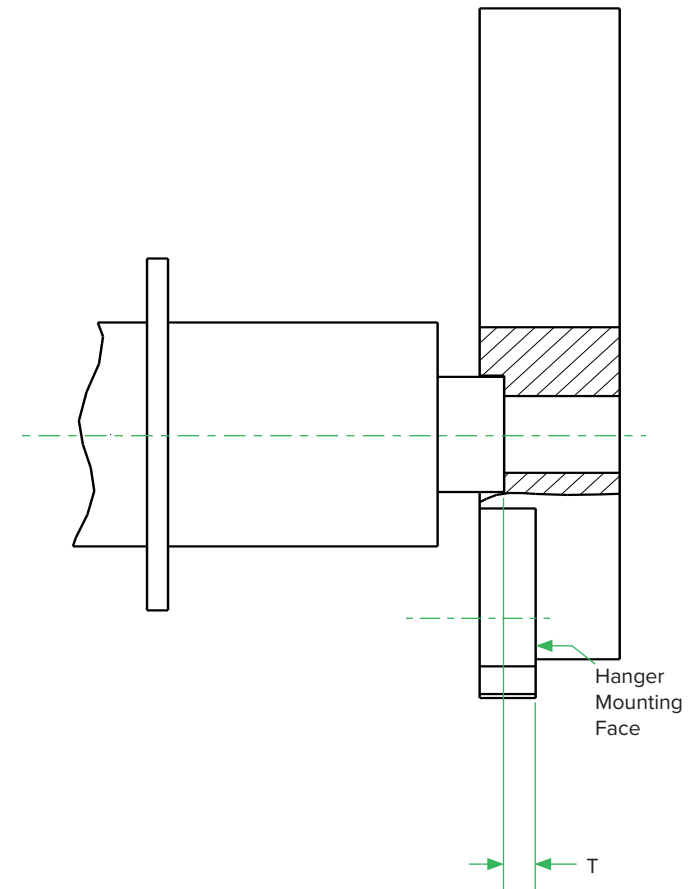

# Frame Rear Dropout Clearance

## 12 Speed Road Chain and Cassette

130 and 135 mm

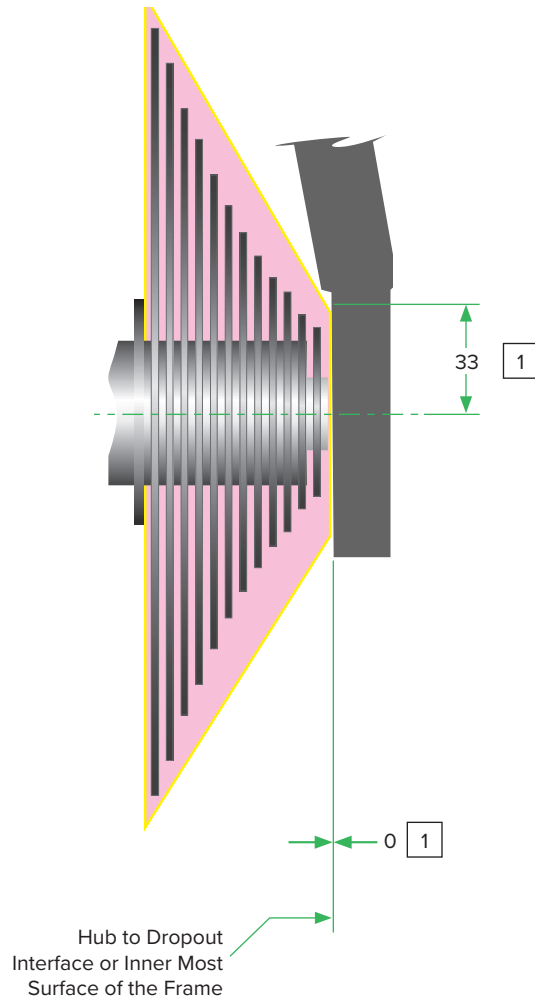

142 mm

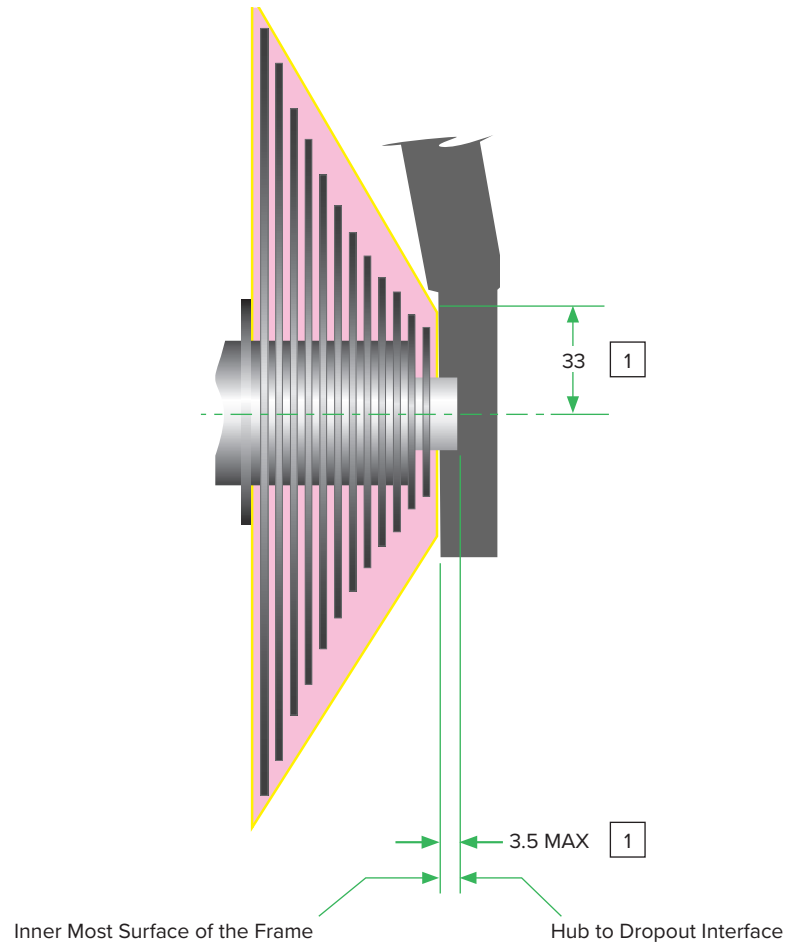

1 An XDR driver body compliant hub is required. Refer to <http://xddriverbody.com/> for freehub driver body specifications.

# Road Cranksets



# Crankarm and Chainring Frame Clearance

12 Speed

Chainring Configuration	L1 (mm)	L2 (mm)	L3 (mm)	L4 (mm)	L5 (mm)	W1 (mm)	W3 (mm)	W4 (mm)	W5 (mm)	W6 (mm)	Q-Factor
50-37	47.5	59.5	76.8	102.4	190	37.8	39.9	47.7	60	60	145
48-35			73.4	98.3							
46-33			68.7	94							

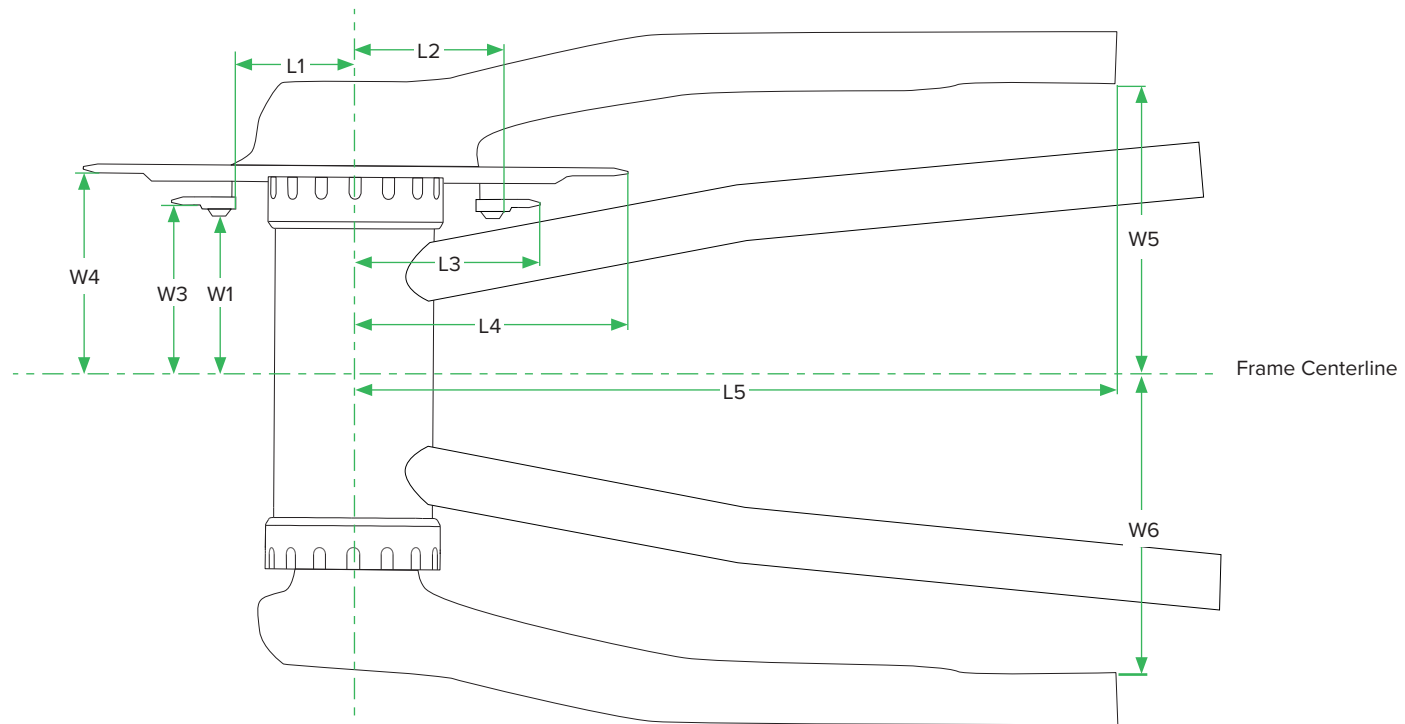

# Crankarm and Chainring Frame Clearance

12 Speed

Chainring Size	L1 (mm)	L2 (mm)	L4 (mm)	L5 (mm)	W1 (mm)	W4 (mm)	W5 (mm)	W6 (mm)	Q-Factor
52	47.5	59.5	108.7	190	40.1	43.3	60	60	145
50			104.6						
48			100.6						
46			96.6						
44			92.5						
42			88.5						
40			84.4						
38			80.4						
36			76.4						

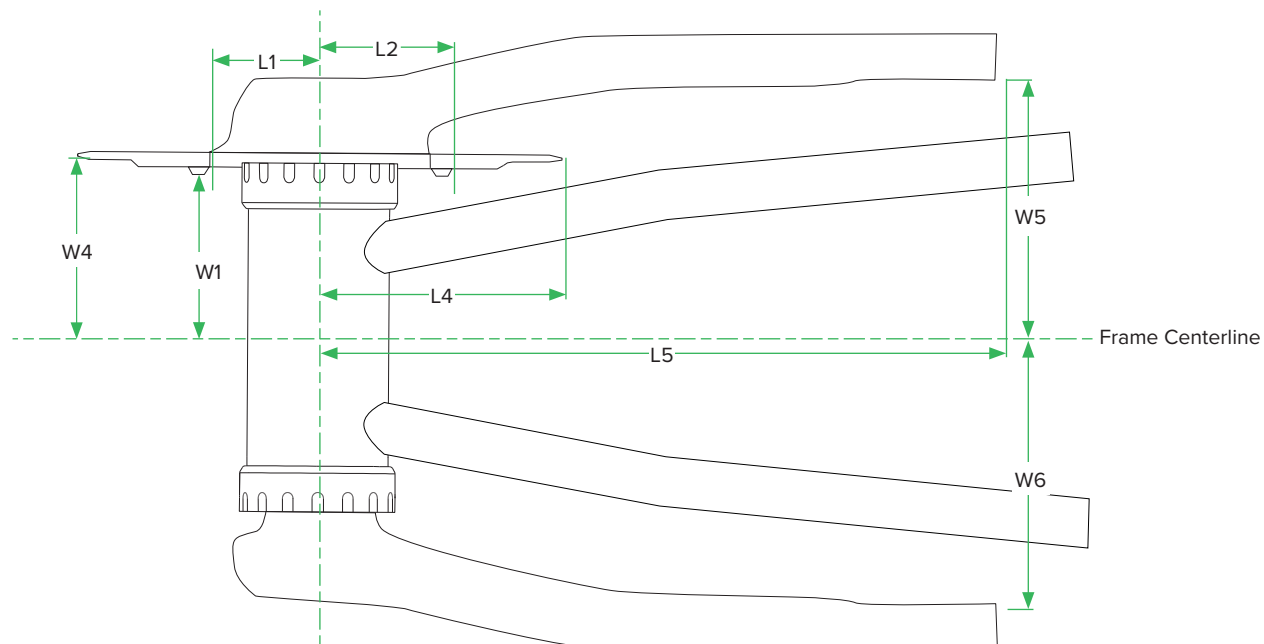

# Crankset Diagram

11 Speed

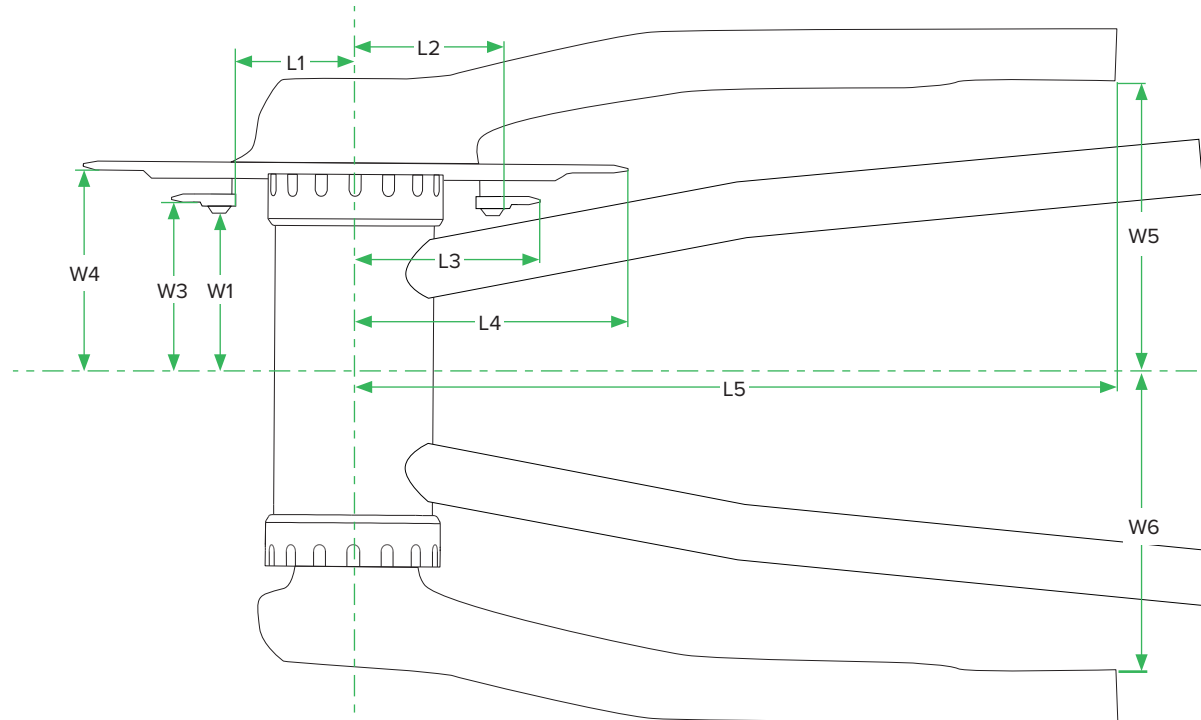

# Crankset Diagram

11 Speed and Singlespeed

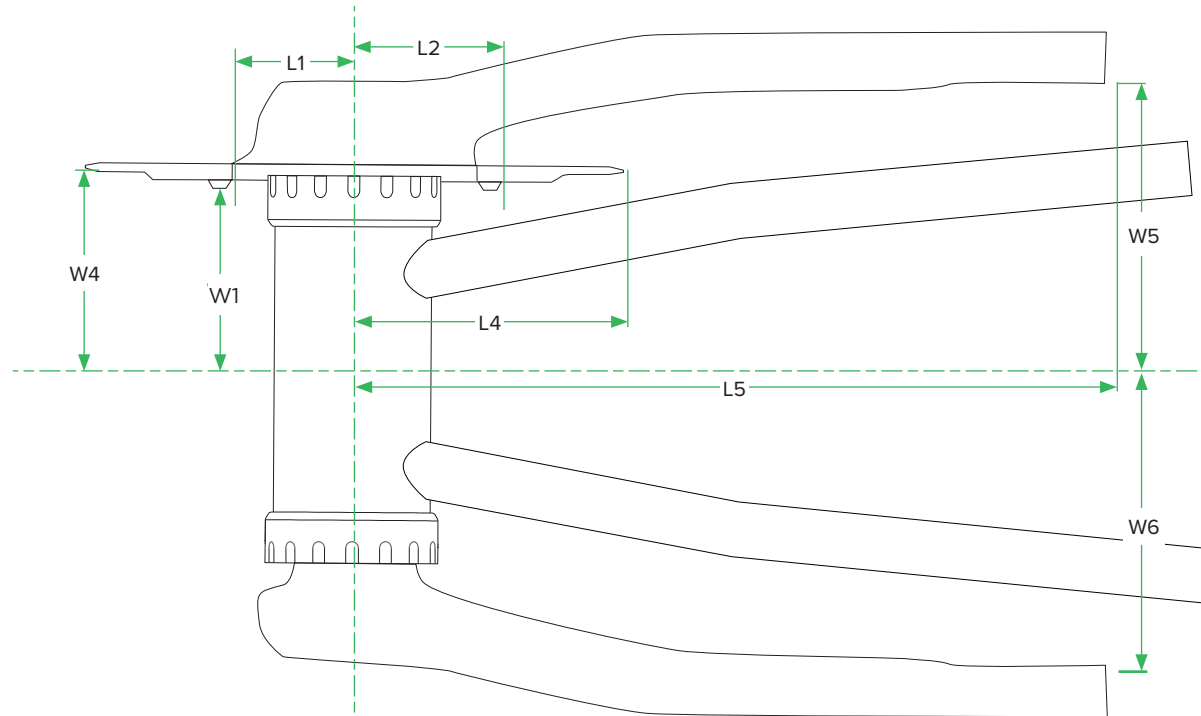

# Crankset Frame Clearance

## 11 Speed

Chainring	L1 (mm)	L2 (mm)	L3 (mm)	L4 (mm)	L5 (mm)	W1 (mm)	W3 (mm)	W4 (mm)	W5 (mm)	W6 (mm)	Q-Factor	BB Type
SRAM RED*/ SRAM Force/ SRAM RED Quarq Power Meters/ Quarq Prime Carbon Power Ready/S902/S952												
55/42	57.0	71.0	88.0	113.1	197.0	38.0	40.0	47.5	60.0 MIN	60.0 MIN	145	GXP BB30 PF30 PFGXP
53/39			81.8	109.2		37.7						
52/36	47.0	61.0	75.0	107.0		38.0		48.0				
50/34			71.0	103.2								
46/36			75.0	95.1								

\* Cranksets can be configured to fit BB386, BB30a, and BBright.

Wide Axle SRAM Rival/ S552												
52/36	47.0	61.0	75.0	106.8	192.1	41.0	42.9	50.6	63.8 GXP/ PFGXP 62.8 BB30	63.8 BB30	154.6 GXP/ PFGXP 152.4 BB30/ PF30	GXP BB30 PF30 PFGXP
50/34			71.0	103.1								

SRAM Rival/ Quarq Prime Aluminum Power Ready												
52/36	47.0	61.0	75.0	106.8	192.1	38.5	40.4	48.1	61.3 GXP/ PFGXP 60.3 BB30/ PF30	61.3 GXP/ PFGXP 60.3 BB30/ PF30	149.6 GXP/ PFGXP 147.4 BB30/ PF30	GXP BB30 PF30 PFGXP
50/34			71.0	103.1								
46/36			75.0	95.1								

SRAM S-390												
50/34	57.3	61	71	103.1	191.5	40.4	42.4	50.1	62	62	149	GXP BB30 PF30 PFGXP
46/34				95.1								

# Crankset Frame Clearance

## 11 Speed

Chainring	L1 (mm)	L2 (mm)	L4 (mm)	L5 (mm)	W1 (mm)	W4 (mm)	W5 (mm)	W6 (mm)	Q-Factor	BB Type	Chainstay Length (mm)
<b>SRAM Force 1</b>											
54	57.0	72.0	112.2	197.0	38.0	43.7	60.0	60.0	145	GXP BB30 PF30 PFGXP	≥ 395
52			108.2								
50	47.0	62.0	104.1								
48			100.1								
46			96.1								
44			92.0								
42			88.0								
40			84.0								
38			79.9								
<b>SRAM Rival 1</b>											
50	47.0	62.7	104.1	192.1	38.0	43.7	61.3 GXP/ PFGXP 60.3 BB30/ PF30	61.3 GXP/ PFGXP 60.3 BB30/ PF30	149.6 GXP/ PFGXP 147.4 BB30/ PF30	GXP BB30 PF30 PFGXP	≥ 395
48			100.1								
46			96.1								
44			92.0								
42			88.0								
40			84.0								
38			79.9								
<b>SRAM Apex 1</b>											
44	49.0	61.0	92.0	191.7	41.3	43.7	62.0	62.1	149	GXP BB30 PF30 PFGXP	≥ 395
42			88.0								
40			83.9								

# Crankset Frame Clearance

## 11 Speed and Singlespeed

Chainring	L1 (mm)	L2 (mm)	L4 (mm)	L5 (mm)	W1 (mm)	W4 (mm)	W5 (mm)	W6 (mm)	Q-Factor	BB Type	Chainstay Length (mm)
<b>SRAM S350-1</b>											
44	47.0	62.7	92.0	196.7	38.0	43.7	60.0	60.0	145	GXP BB30 PF30 PFGXP	≥ 395
42			88.0								
40			84.0								
<b>Omnium</b>											
48	64.5	78.0	99.1	195.4	35.5	42.5	55.0	54.7	145	GXP	≥ 395

# Crankset Frame Clearance

8/9/10 Speed

Chainring	L1 (mm)	L2 (mm)	L3 (mm)	L4 (mm)	L5 (mm)	W1 (mm)	W3 (mm)	W4 (mm)	W5 (mm)	W6 (mm)	Q-Factor	BB Type
<b>SRAM Apex</b>												
53/39	57.0	71.0	81.0	109.2	196.7	38.0	40.0	47.3	60.0	60.0	145	GXP BB30 PF30 PFGXP
50/34	47.0	61.0	71.0	103.2								
48/34				99.0								
46/36			75.0	95.1								
<b>Touro</b>												
53/39/30	29.0	41.0	63.0	109.2	190.5	38.5	40.5	48.0	61.0	59.0	145	Power Spline
48	47.0	71.0	NA	99.0				NA				
G52	57.0		107.2	112.5				46.0				
G53		Square										



# Spider Frame Clearance

## Quarq DZero Platform Power Meters

Model	L1 (mm)	L2 (mm)	L3 (mm)	L4 (mm)	W1 (mm)	W2 (mm)	W3 (mm)	W4 (mm)	W5 (mm)
DZero 110	24.0	27.0	38.5	46.95	47.6	46.7	44.4	41.0	42.0
DZero 130			39.0	56.95					
DFOUR			38.5	46.95					41.9

Cranksets can be configured to fit BB386, BB30a, and BBright.

DZero Carbon, DFour, and RED DZero crankset frame clearance is the same as SRAM Force. See 2x11 Crankset Frame Clearance page.

DZero Aluminum crankset frame clearance is the same as SRAM Rival. See 2x11 Crankset Frame Clearance page.

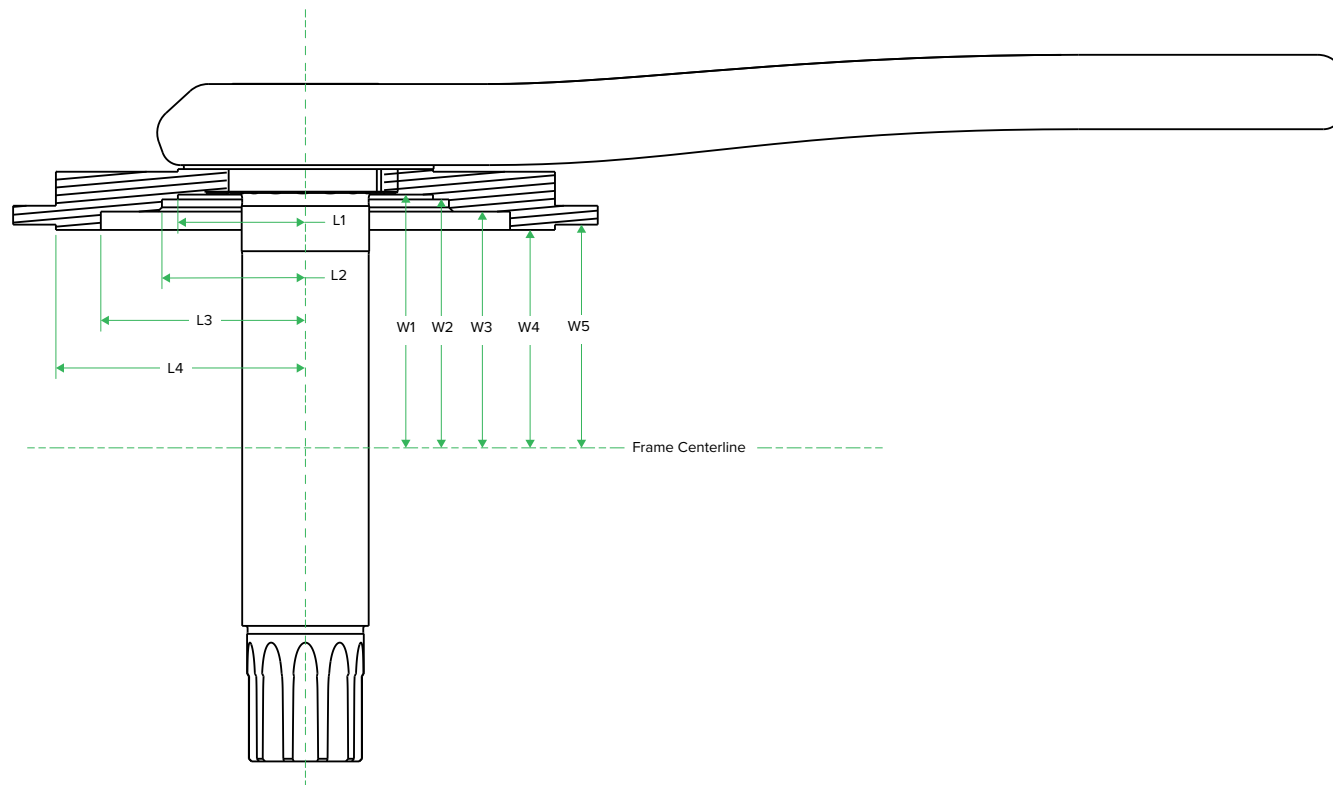

# Spider Frame Clearance

## Quarq AXS Platform Power Meters

L1 (mm)	L2 (mm)	L3 (mm)	W1 (mm)	W2 (mm)	W3 (mm)	W4 (mm)
24.0	27.0	37.2	48	46.7	44.3	40.7

Refer to Chainring Crankarm Clearance 1x, 2x for chainring and crankarm to frame clearance.

Consider clearance in this area if using a wide format BB shell such as BB386 or PressFit 86.5

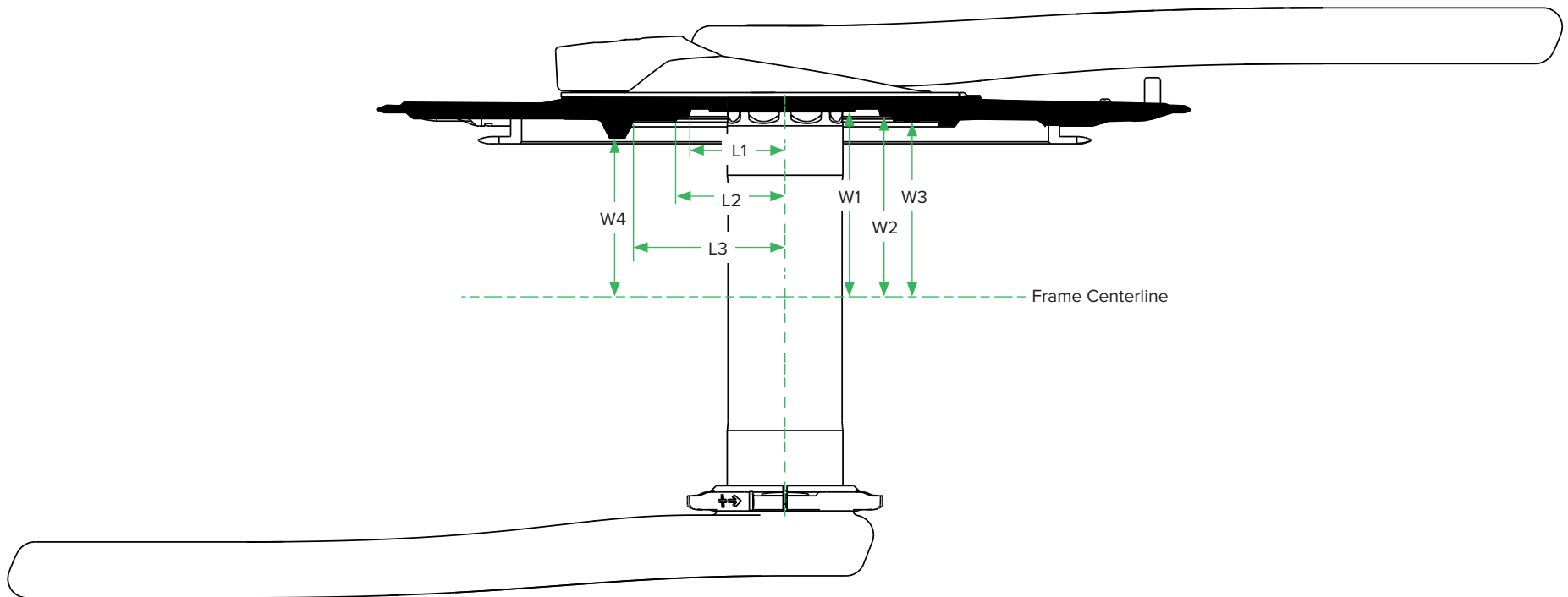

# Bottom Bracket Shell Specifications

# BSA and Italian Bottom Bracket

## Road Bottom Bracket Frame Shell Specification

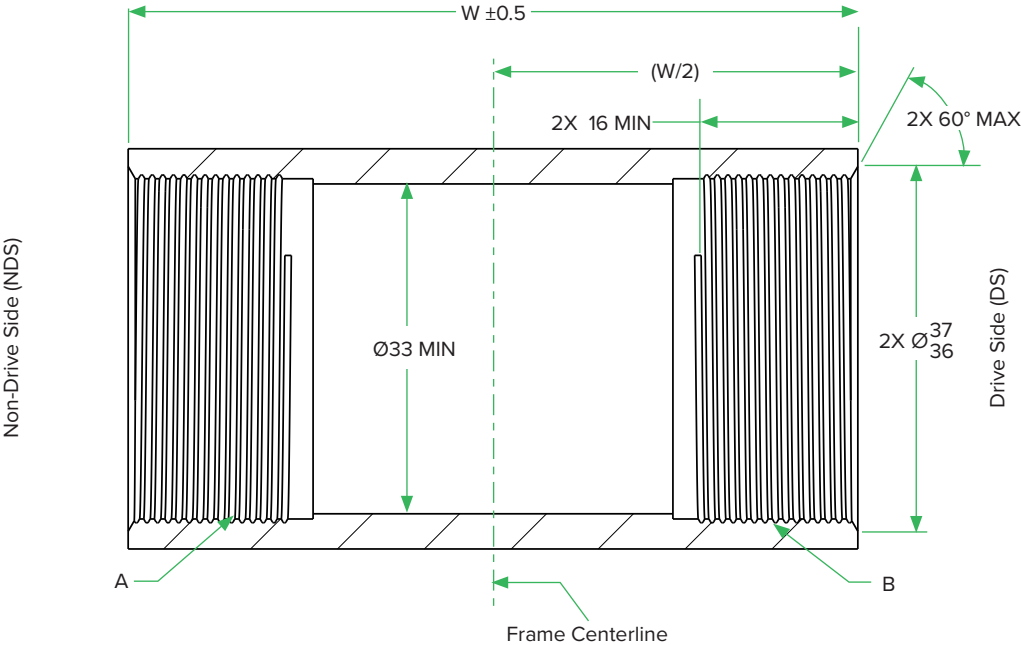
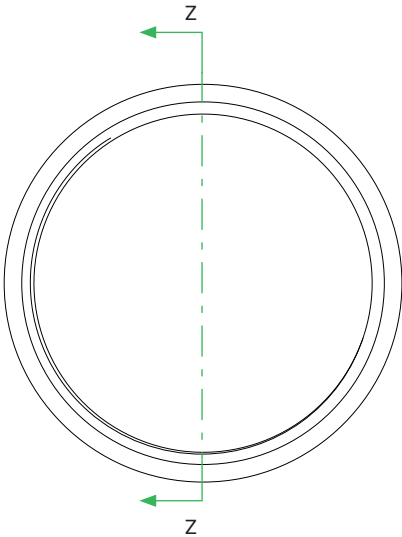

Section Z-Z

	W	A	B
BSA 68	$68 \pm 0.5$	BC 1.37" x 24 TPI R.H.*	BC 1.37" x 24 TPI L.H.*
Italian	$70 \pm 0.5$	36 mm x 24 TPI R.H.	

\*Reference JIS B 0225

# T47 85.5

## Road Bottom Bracket Frame Shell Specification

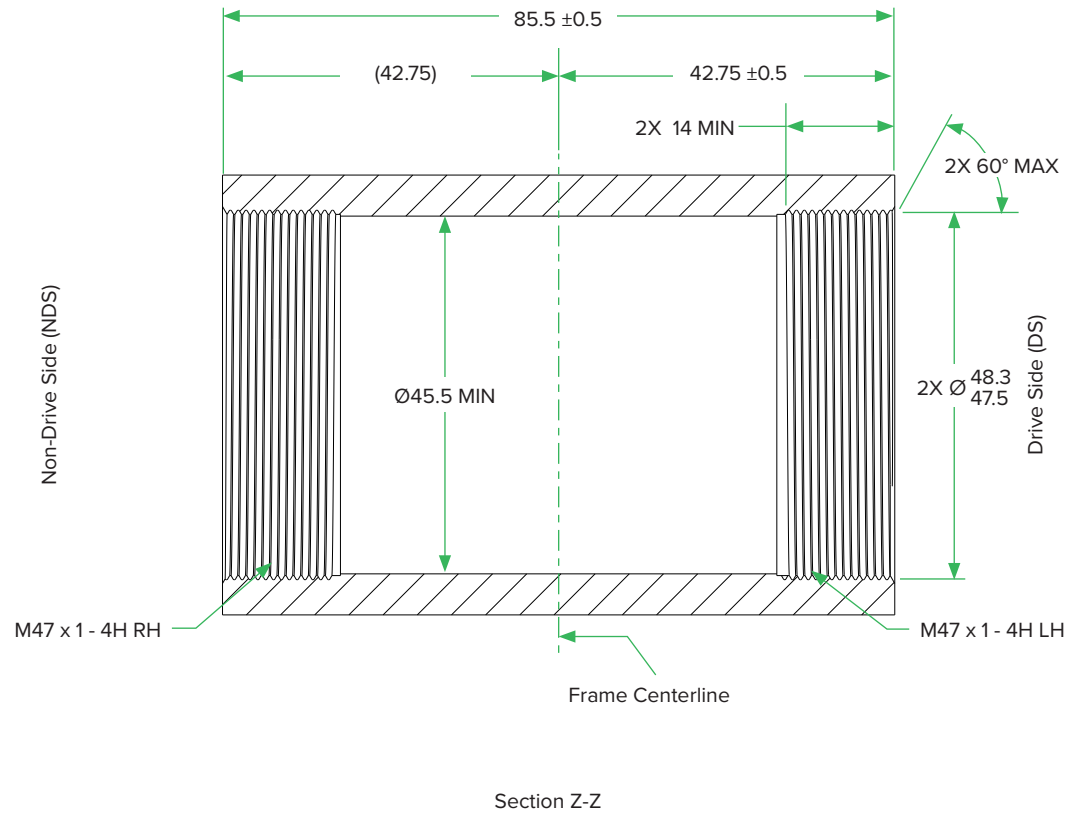
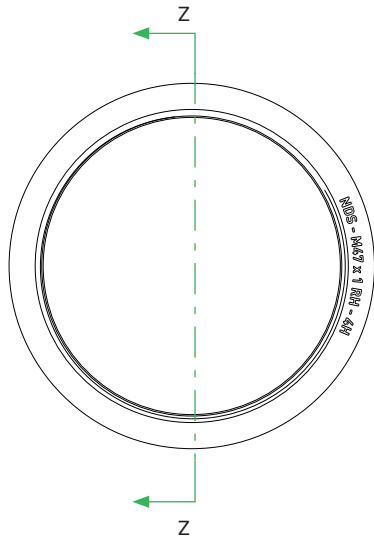

# PressFit 30

## Road Bottom Bracket Frame Shell Specification

SRAM PressFit 30 (PF30) bottom brackets have been designed and tested to work within the bounds of the dimensions and tolerances in the shell specifications. Materials, manufacturing methods, and frame shell designs can potentially influence the performance of the bottom bracket, even when the shell is manufactured to these specifications. In these instances, it is recommended that bicycle manufacturers confirm the bottom bracket system performance when implemented in their design.

Things that should be considered when evaluating the frame and bottom bracket interaction include, but are not limited to:

- Loosening of the adapter cups from the bottom bracket shell (frame material choice can greatly affect friction coefficient).
- Binding of bearings within the bottom bracket.

For more information regarding PF30 bottom bracket technical information, contact your SRAM representative.

	Dim W	Dim DS	Dim NDS
PF30 68	68	34	
PF30 73-A	73	34	39
PF30 79-A <span style="border: 1px solid black; padding: 0 2px;">4</span>	79	34	45
PF30 83-A	83	39	44
PF30 86.5	86.5	43.25	

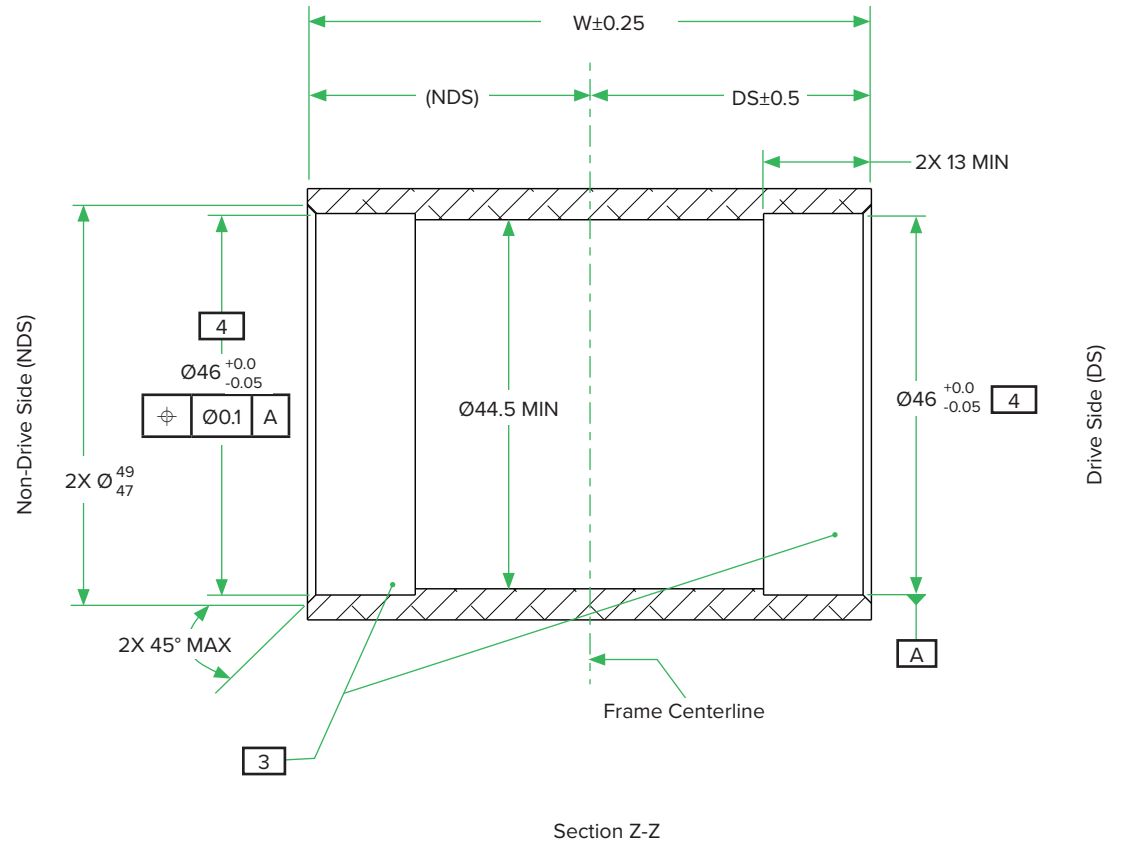
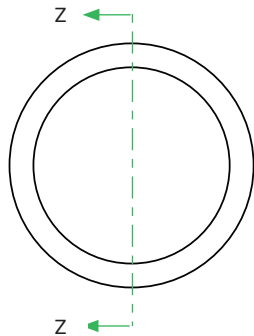

- 1 Dimensions apply after finishing.
- 2 Only dimensions essential to bottom bracket PressFit and function are shown. All other details are left to the discretion of the frame or component designer. Dimensions shown do not take the place of proper frame, bottom bracket shell, or crankset design.
- 3 PressFit surfaces should be unpainted.
- 4 PF30 79-A Only: Ø45.88-45.96

# PressFit Road 86.5

## Road Symmetric Frame Shell Specification

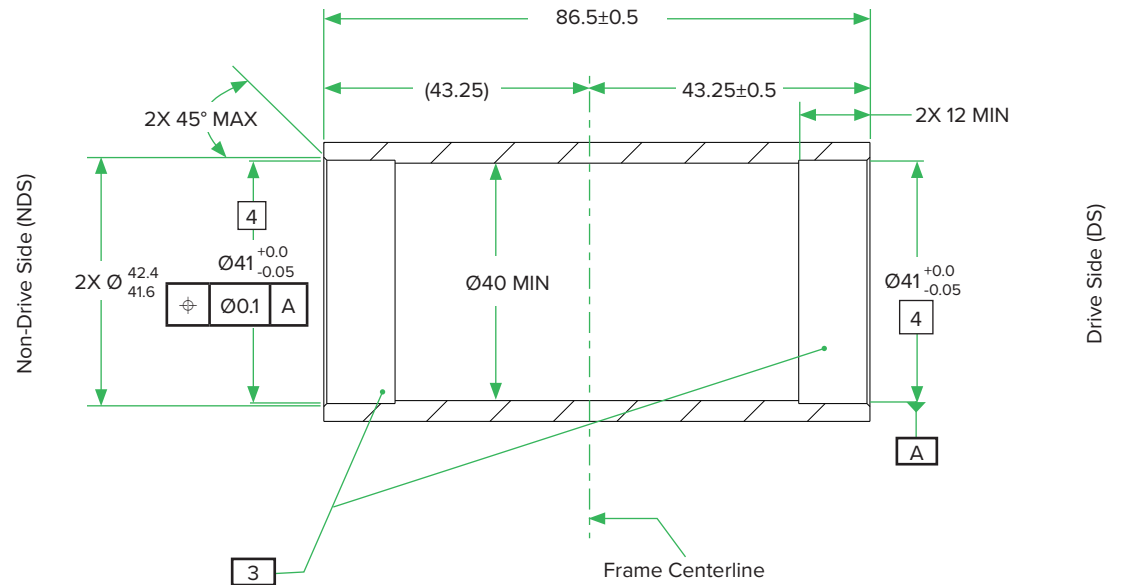
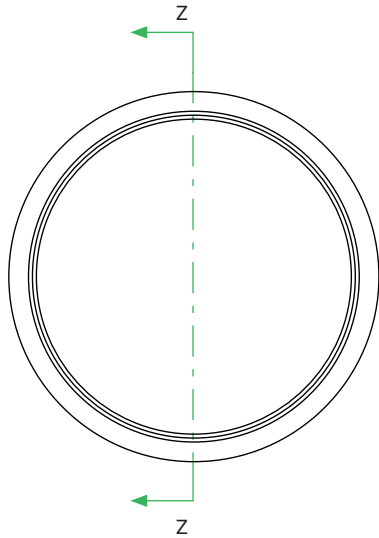

Section Z-Z

- 1 Dimensions apply after finishing.
- 2 Only dimensions essential to bottom bracket PressFit and function are shown. All other details are left to the discretion of the frame or component designer. Dimensions shown do not take the place of proper frame, bottom bracket shell, or crankset design.
- 3 PressFit surfaces should be unpainted.
- 4 Tolerance applies to depth of 12 mm inboard from the outer face of each side.

# BB30

## Information

Information for the BB30 drawing and legal agreement can be found on [www.BB30standard.com](http://www.BB30standard.com). Use of the information contained in the drawing is forbidden without reviewing and agreeing to the legal terms and conditions found on [www.BB30standard.com](http://www.BB30standard.com). By using the information contained in the drawing you are certifying that you have agreed to the terms and conditions found within that legal agreement.



# DUB Bottom Brackets

# DUB BSA 68

## Bottom Bracket Specification

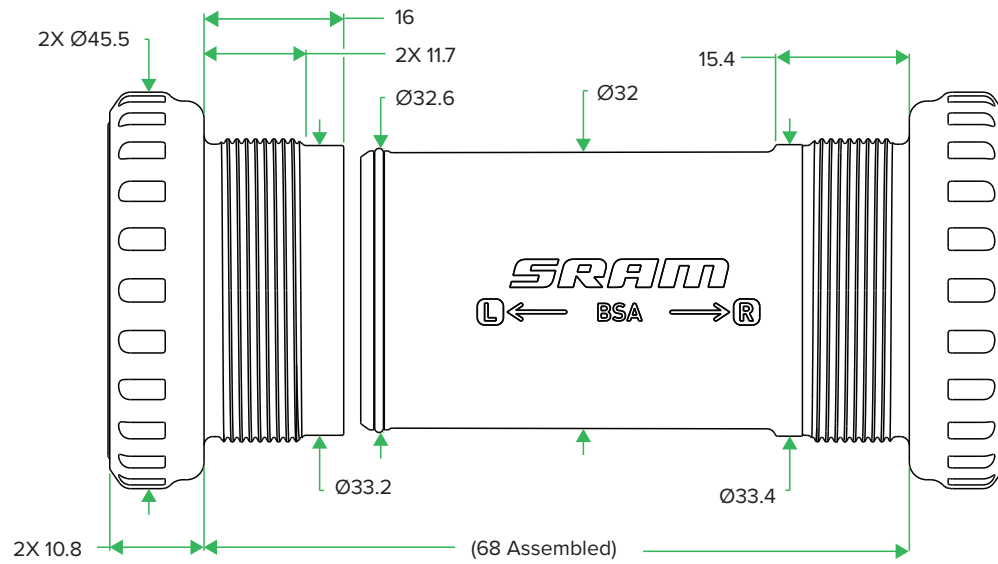

# DUB T47 85.5

## Bottom Bracket Specification

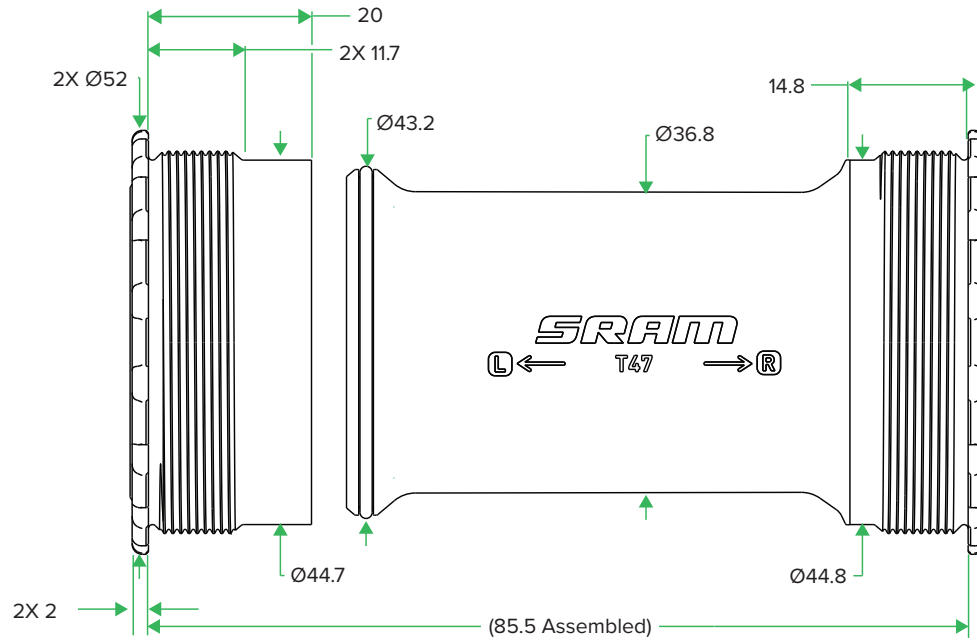

# DUB PressFit 30

## Bottom Bracket Specification

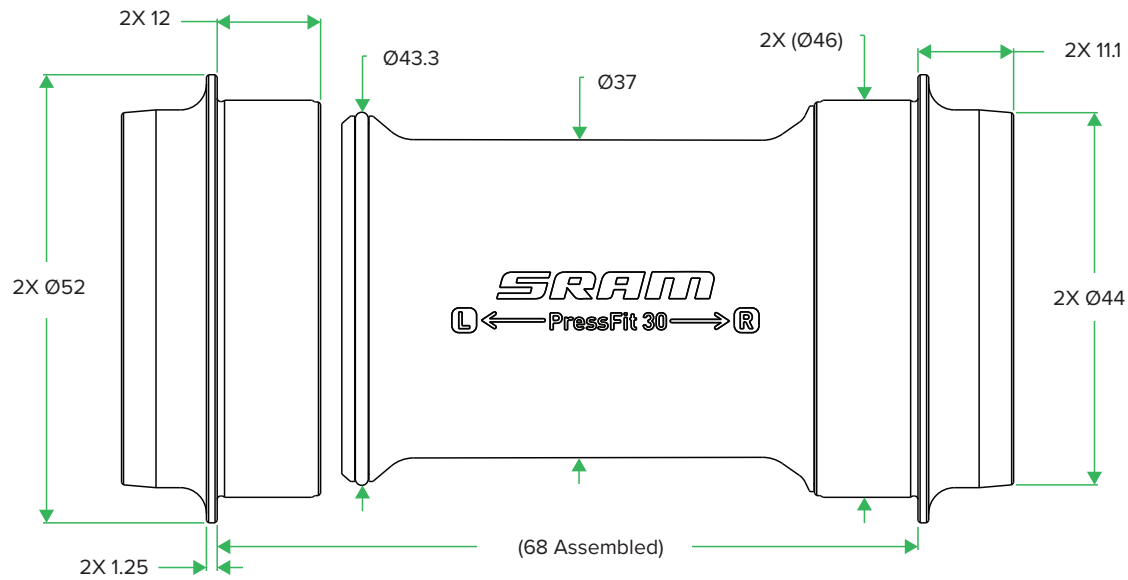

1 Consider cable and hose clearances through the bottom bracket area of the frame.

# DUB PressFit 30 73-A

## Bottom Bracket Specification

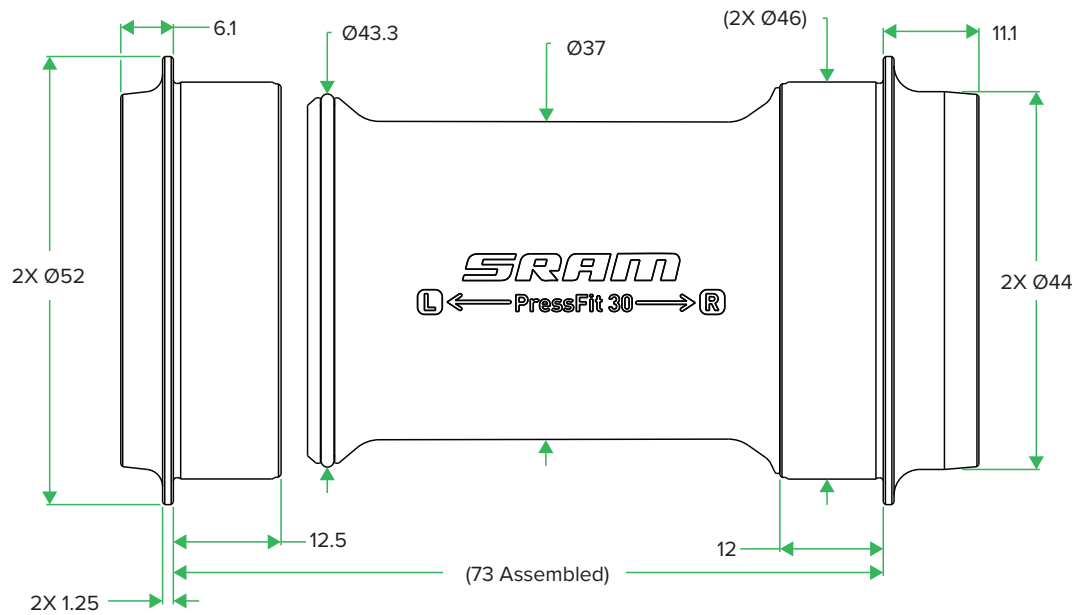

1 Consider cable and hose clearances through the bottom bracket area of the frame.

# DUB PressFit 30 79-A

## Bottom Bracket Specification

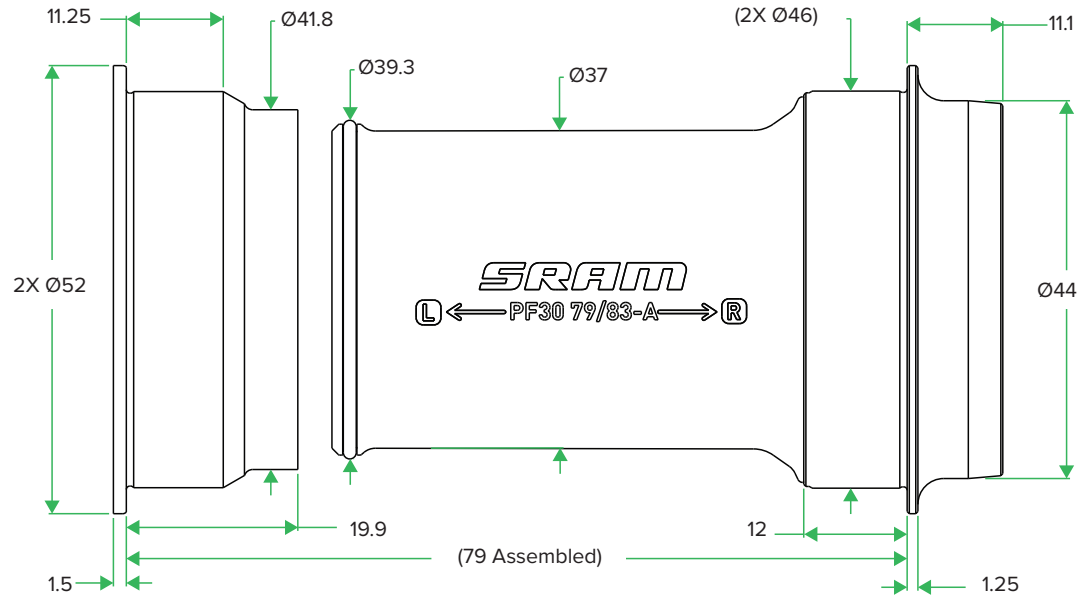

1 Consider cable and hose clearances through the bottom bracket area of the frame.

# DUB PressFit 30 83-A

## Bottom Bracket Specification

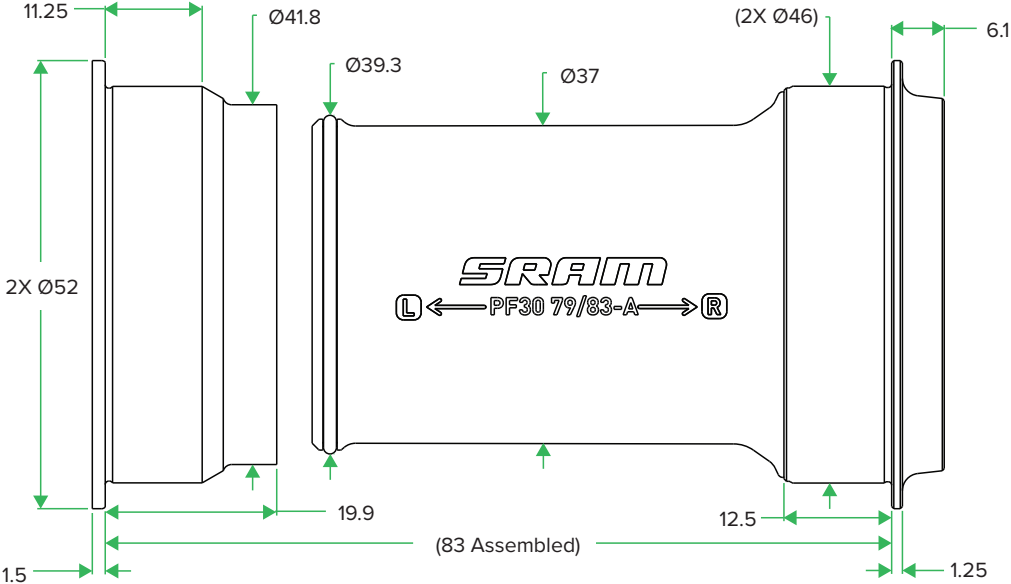

1 Consider cable and hose clearances through the bottom bracket area of the frame.

# DUB PressFit 86.5

## Bottom Bracket Specification

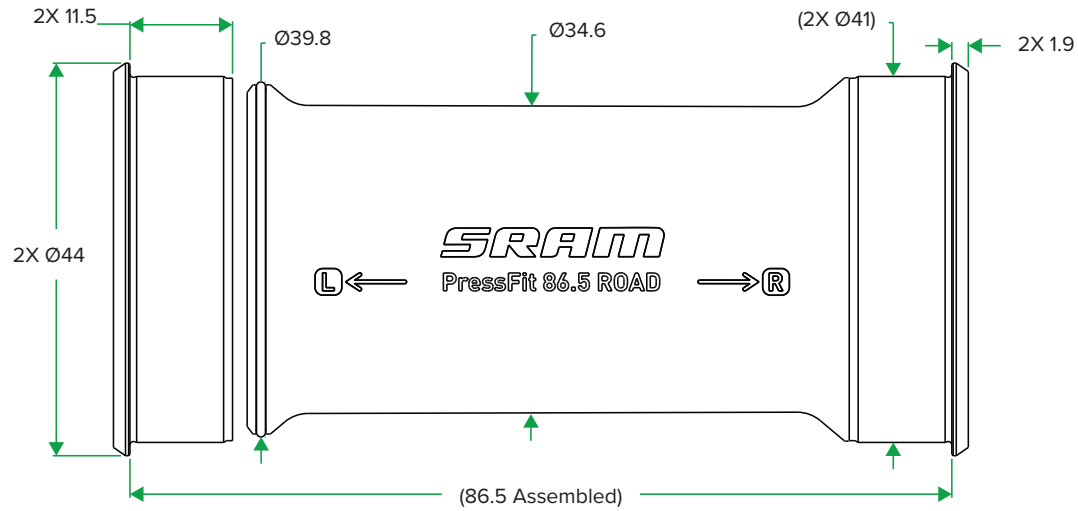

1 Consider cable and hose clearances through the bottom bracket area of the frame.



# DUB BB386

## Bottom Bracket Specification

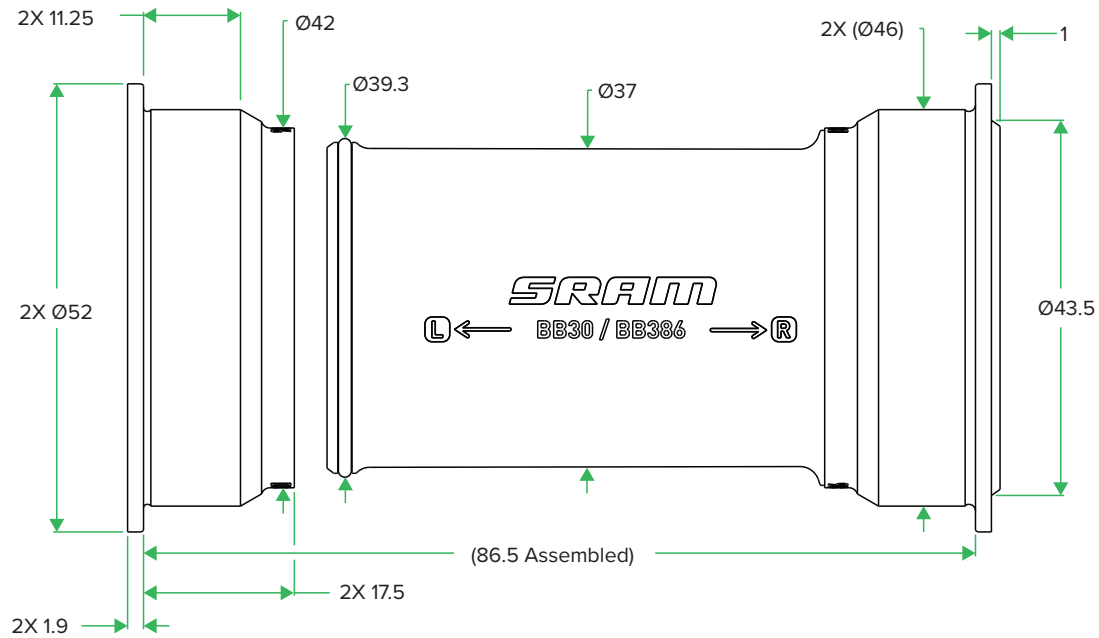

1 Consider cable and hose clearances through the bottom bracket area of the frame.

# DUB BB30

## Bottom Bracket Specification

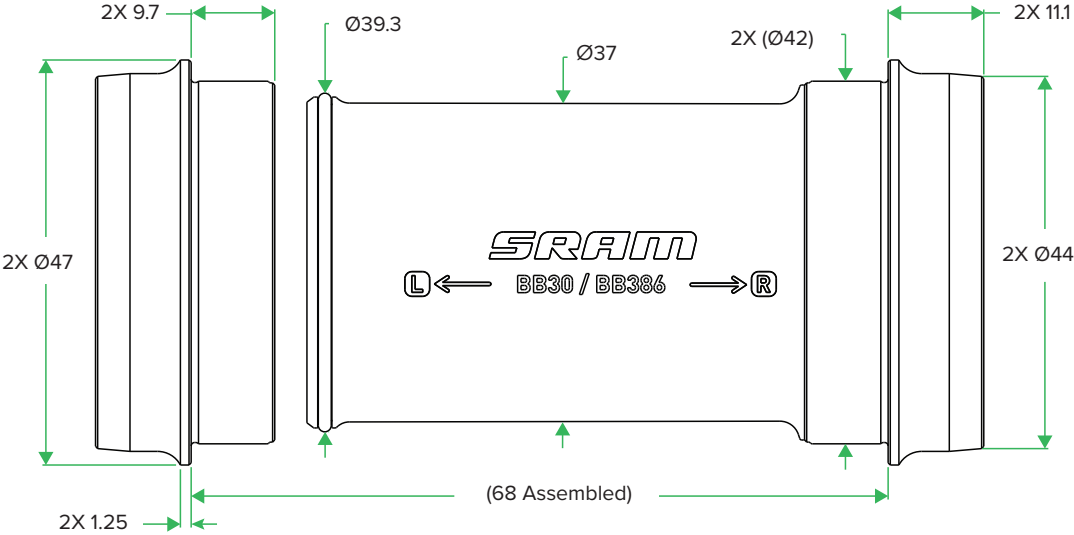

1 Consider cable and hose clearances through the bottom bracket area of the frame.

# DUB BB30 73-A

## Bottom Bracket Specification

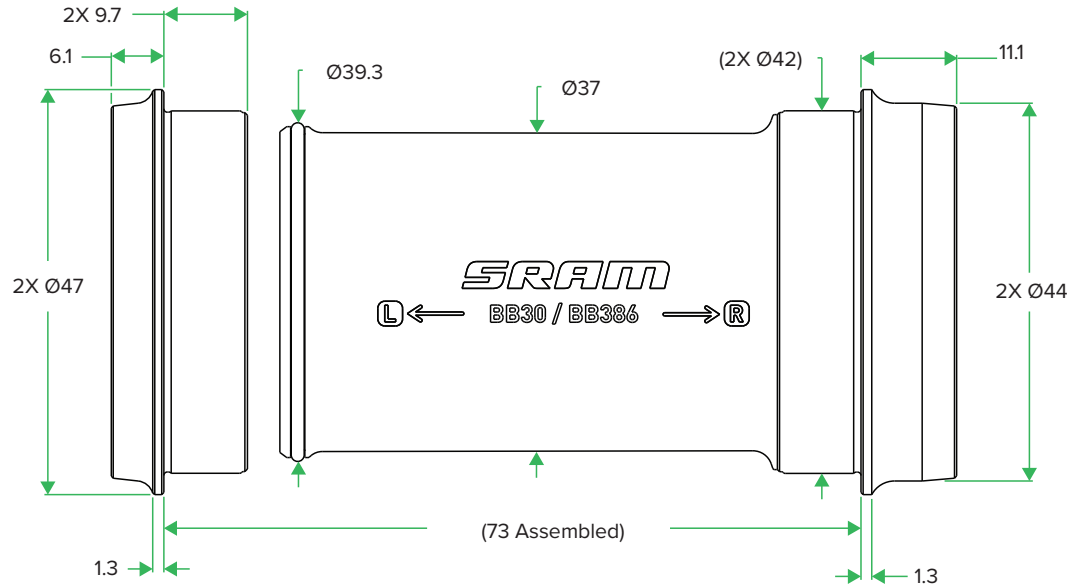

1 Consider cable and hose clearances through the bottom bracket area of the frame.

# DUB BB30 83-A

## Bottom Bracket Specification

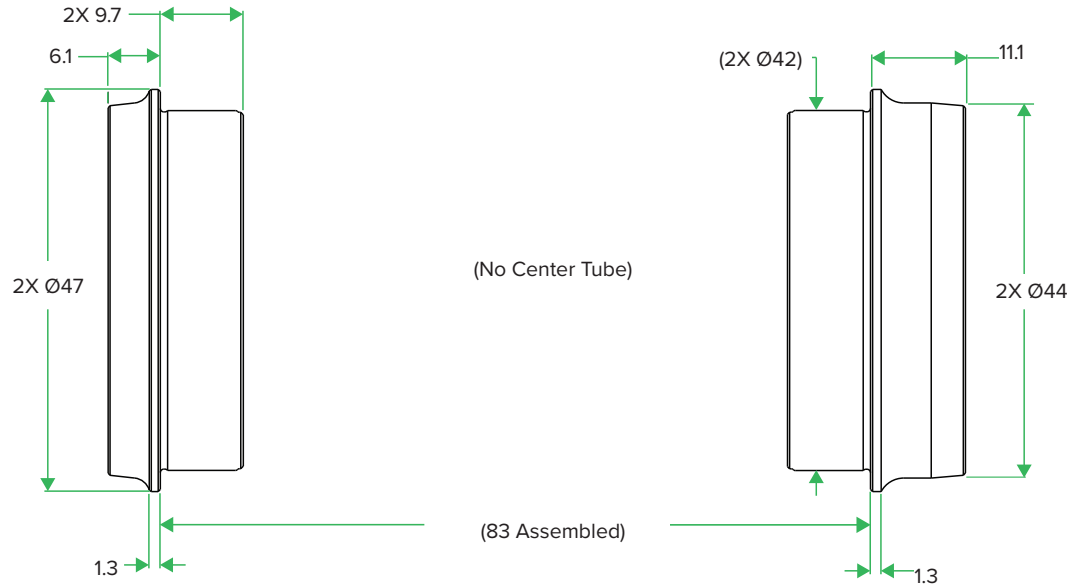

1 Consider cable and hose clearances through the bottom bracket area of the frame.

# Brakes

# Safety Guidelines for Rotor Size and Brake Pad Material

## All SRAM Road Hydraulic Disc Brakes

	Intended Use	Brake pad material	Minimum rotor size (mm)
Riding Type	Road Riding	Organic	160
	Closed Course Racing	Organic or Metal Sintered	140

### **⚠WARNING - CRASH HAZARD**

SRAM disc brakes pass laboratory testing designed to simulate worst case riding conditions. The rotor size and pad compound materials recommendations were generated through controlled testing. Use of any combination not mentioned above will void the warranty and could result in a crash.

# SRAM Force eTap AXS

## Disc Brake Hose Length Specification

SJ (Stealth-a-majig)

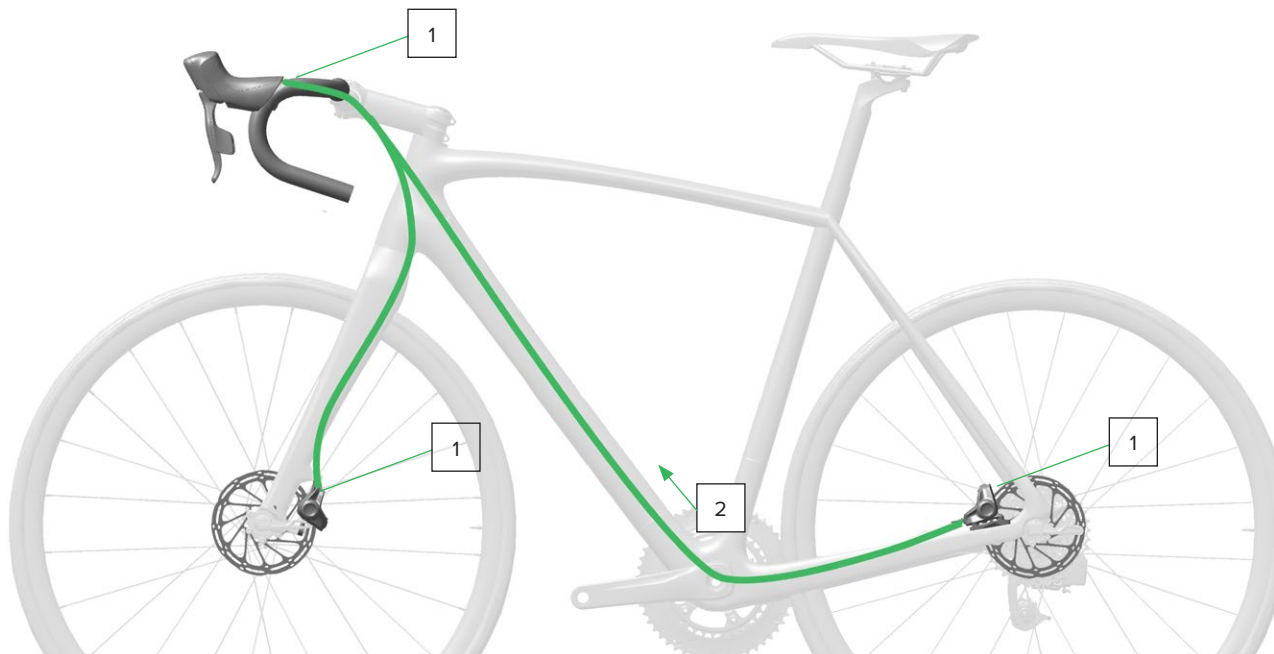
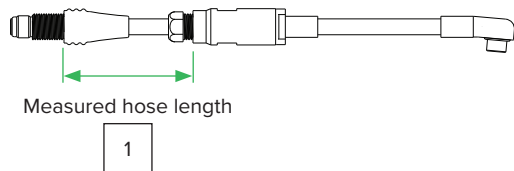

- 1 FG (Finished Good) hose equals the measured hose length from the hood/handlebar interface to the caliper plus 20 mm.
- 2 The SJ hose routing is from back to front of bike.
- 3 For internal routing, the SJ connection requires a hole in the frame or fork that is at least  $\text{Ø}5.1$  mm.
- 4 Hose bend radius at  $20^\circ\text{C}$  = 30 mm minimum.
- 5 All surfaces that come in contact with brake hose to be free of burrs and sharp edges.
- 6 Stealth-a-majig for initial assembly only. A bleed is required if the system is disconnected and reconnected.
- 7 SRAM Brake systems are not compatible with mineral based fluids such as damping fluid, mineral oil, fork fluid, or RockShox Reverb fluid. **Use only DOT 4 or DOT 5.1 fluids with SRAM Hydraulic brakes.**

# SRAM RED eTap AXS

## Disc Brake Hose Length Specification

SJ (Stealth-a-majig)

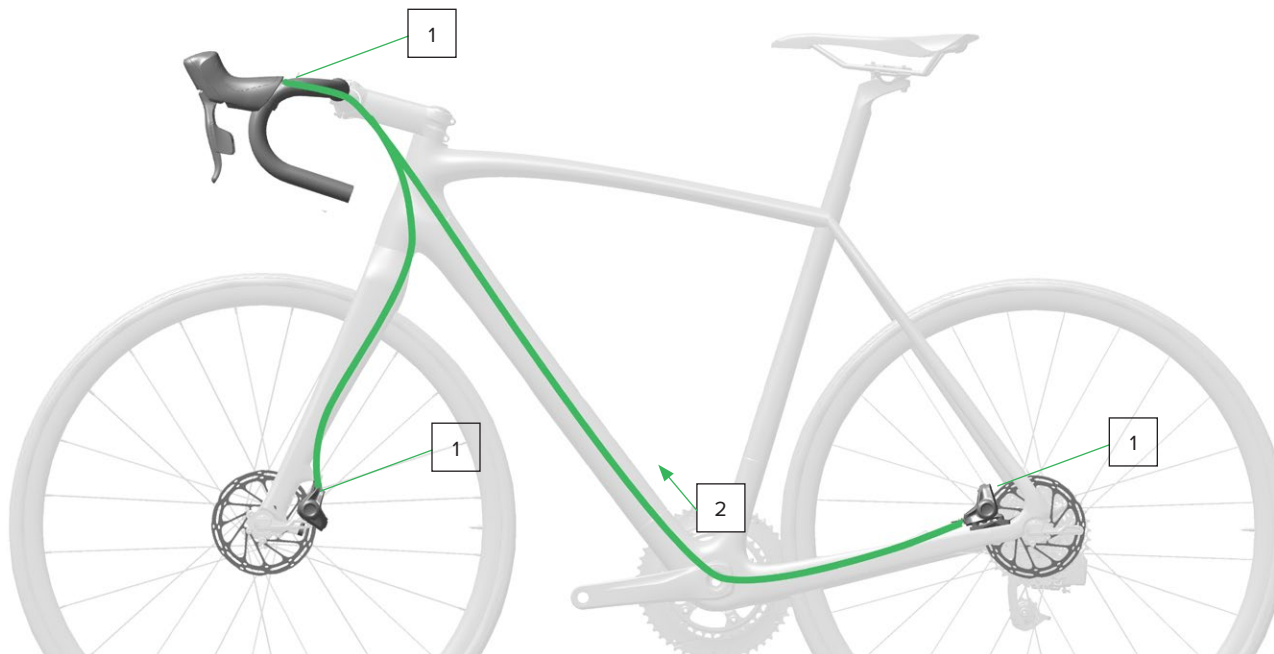
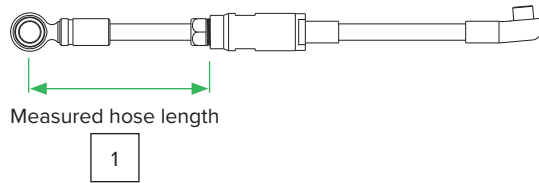

- 1 FG (Finished Good) hose equals the measured hose length from the hood/handlebar interface to the caliper plus 10 mm.
- 2 The SJ hose routing is from back to front of bike.
- 3 For internal routing, the SJ connection requires a hole in the frame or fork that is at least  $\text{Ø}5.1$  mm.
- 4 Hose bend radius at  $20^\circ\text{C}$  = 30 mm minimum.
- 5 All surfaces that come in contact with brake hose to be free of burrs and sharp edges.
- 6 Stealth-a-majig for initial assembly only. A bleed is required if the system is disconnected and reconnected.
- 7 SRAM Brake systems are not compatible with mineral based fluids such as damping fluid, mineral oil, fork fluid, or RockShox Reverb fluid. **Use only DOT 4 or DOT 5.1 fluids with SRAM Hydraulic brakes.**



# S-900 Aero HRD

## Disc Brake Hose Routing Specification

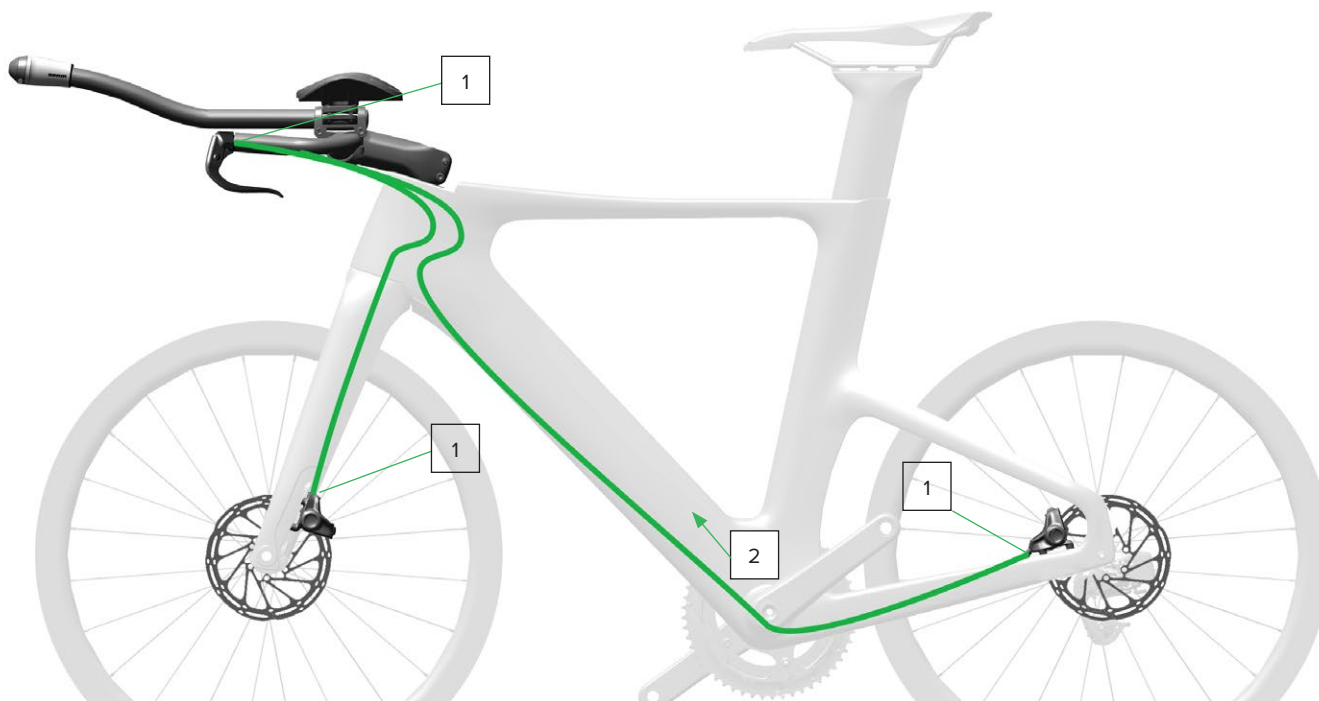

- 1 FG (Finished Good) hose equals the hose length from the hood/handlebar interface to the caliper.
- 2 The SJ hose routing is from back to front of bike.
- 3 For internal routing, the SJ connection requires a hole in the frame or fork that is at least  $\text{Ø}5.1$  mm.
- 4 Hose bend radius at  $20^{\circ}\text{C}$  = 30 mm minimum.
- 5 All surfaces that come in contact with brake hose to be free of burrs and sharp edges.
- 6 Stealth-a-majig for initial assembly only. A bleed is required if the system is disconnected and reconnected.
- 7 SRAM Brake systems are not compatible with mineral based fluids such as damping fluid, mineral oil, fork fluid, or RockShox Reverb fluid. **Use only DOT 4 or DOT 5.1 fluids with SRAM Hydraulic brakes.**

# Flat Mount Fork Specification

All SRAM Flat Mount Calipers

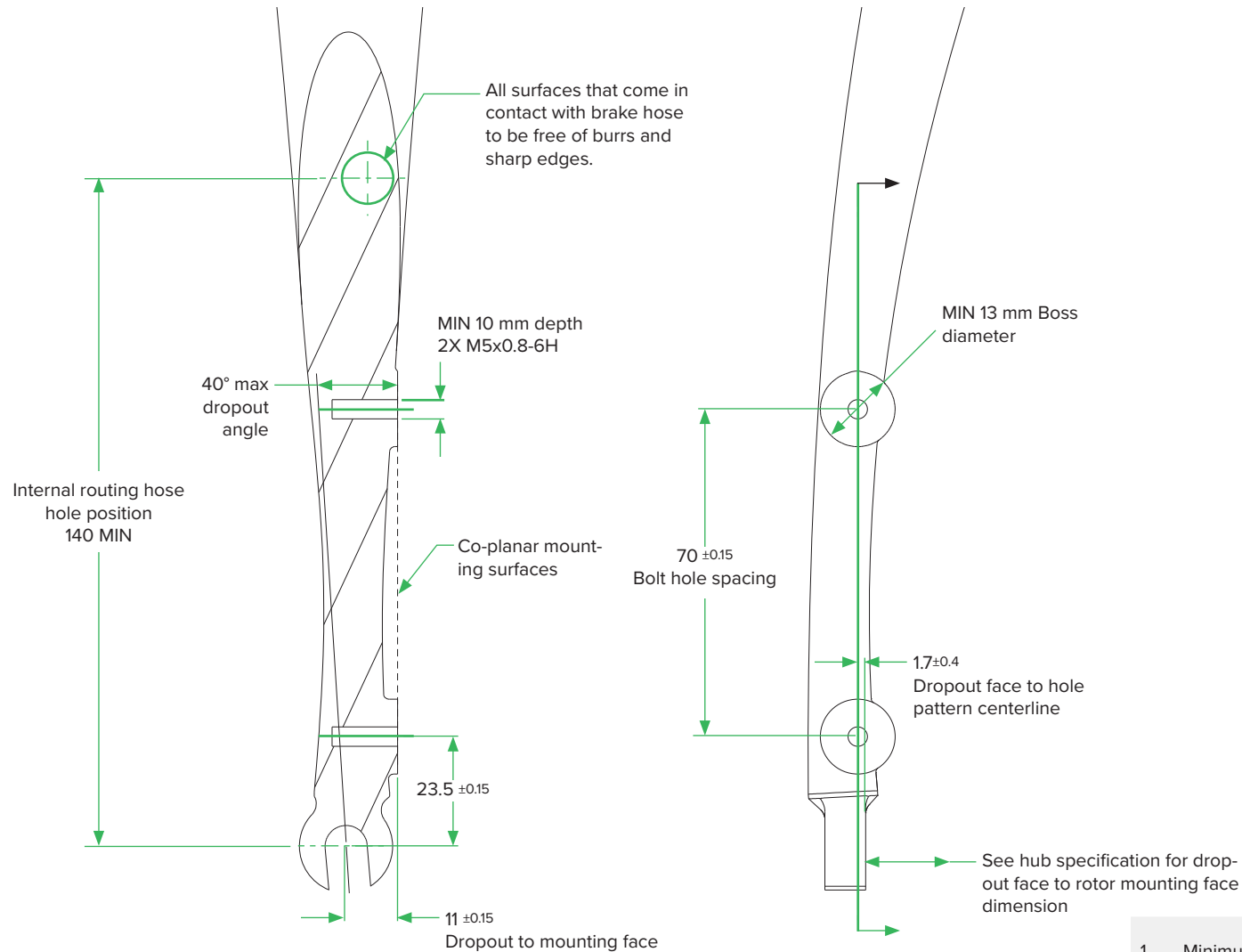

1 Minimum internal routing hole position does not apply to Connect-a-majig.

# Flat Mount Frame Specification

All SRAM Flat Mount Calipers

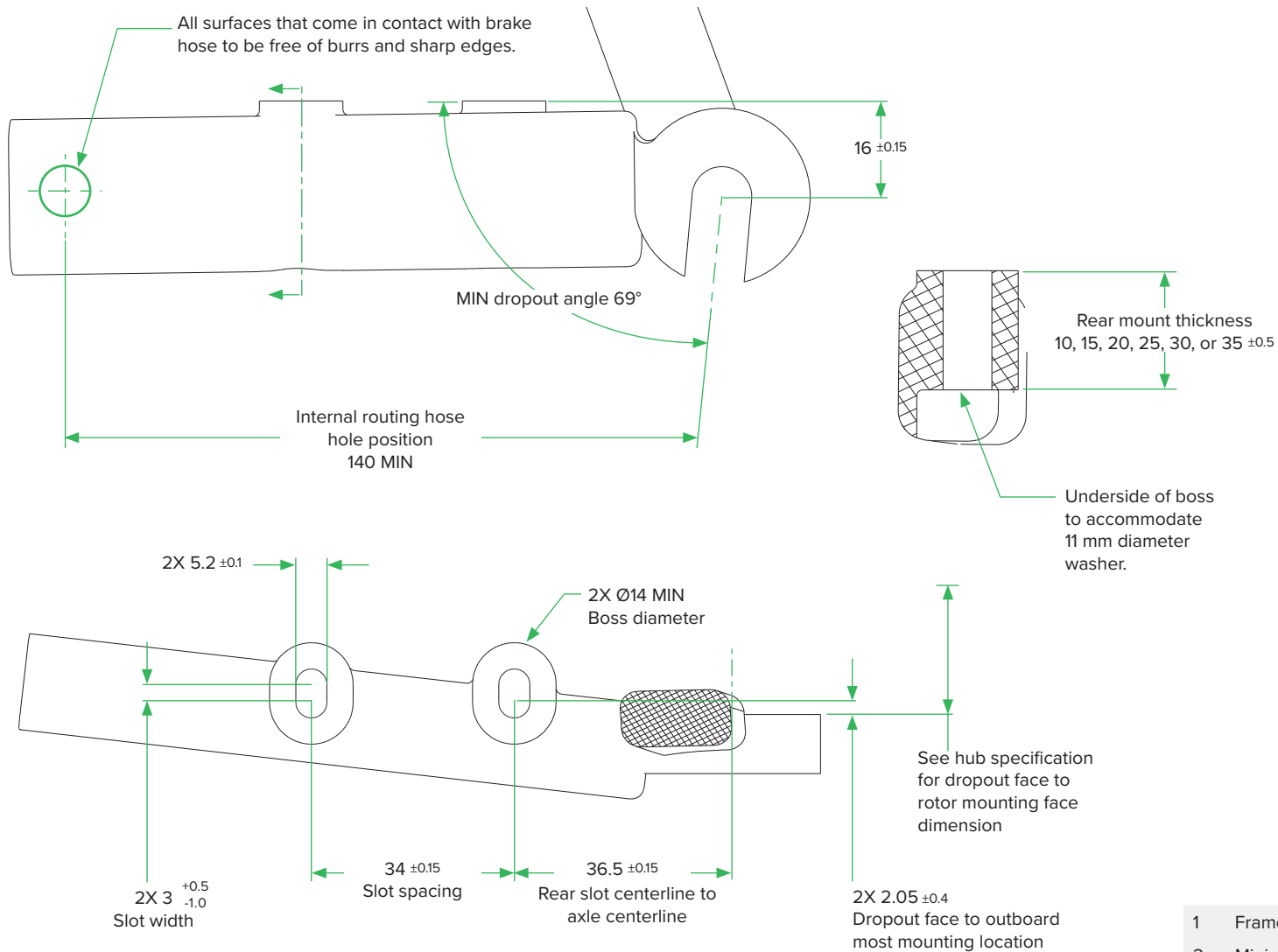

- 1 Frame and caliper interface may reach 120°C.
- 2 Minimum internal routing hole position does not apply to Connect-a-majig.

# Flat Mount Frame Specification

All SRAM Flat Mount Calipers

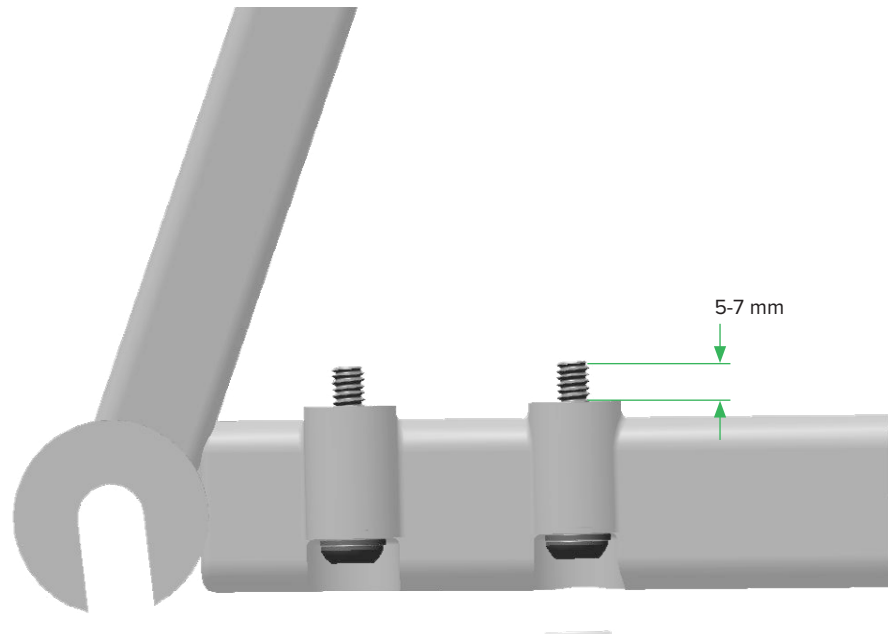

## **⚠WARNING - CRASH HAZARD**

There must be 5-7 mm of mounting bolt thread engagement when mounting brake calipers to forks and frames with flat mount hardward and brackets. Riding a bike with improper bolt engagement can allow the brakes to disengage from the bicycle, which can lead to a crash and serious injury or death to the rider.

1 Available in rear bolt lengths: 17, 22, 27, 32, 37, and 42 mm

# Post Mount Fork Specification

All SRAM Post Mount Calipers

Direct mount rotor size	A (mm)	B(mm)	C (mm)
140 mm	47.2	2.2	0.94
160 mm	56.0	6.8	

Fork Mount

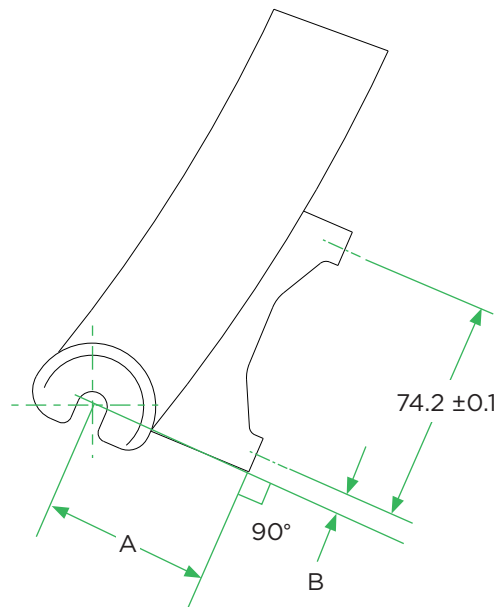

Fork Mount Dropout

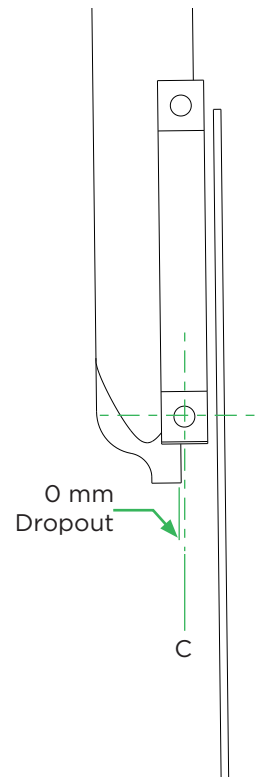

# Post Mount Frame Specification

All SRAM Post Mount Calipers

Direct mount rotor size	A (mm)	B(mm)	130 and 135 QR	142 and 148 Thru
			C (mm)	
140 mm	47.2	2.2	5.7	9.2
160 mm	56.0	6.8		

Chainstay Mount

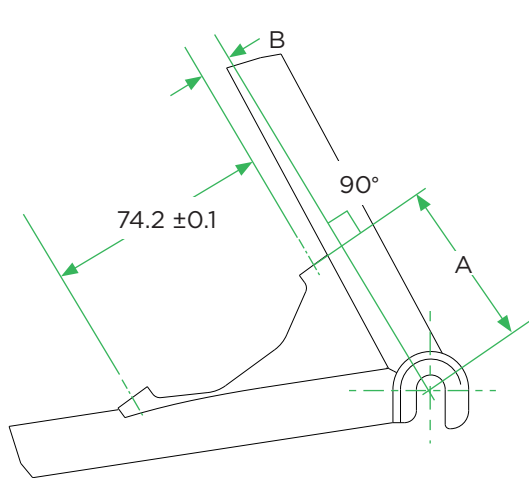

Seatstay Mount

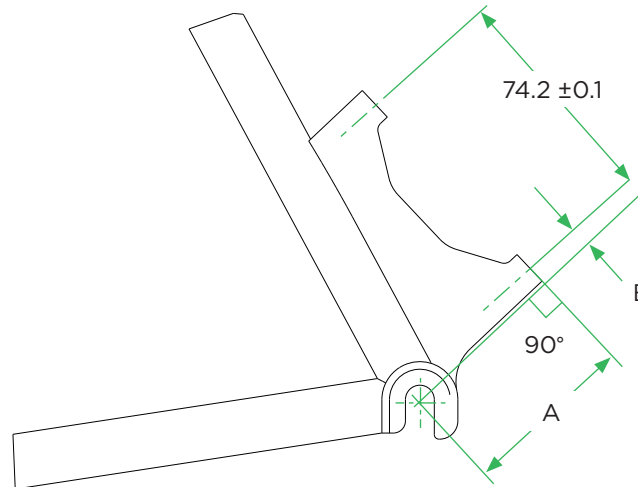

Frame Mount Dropout

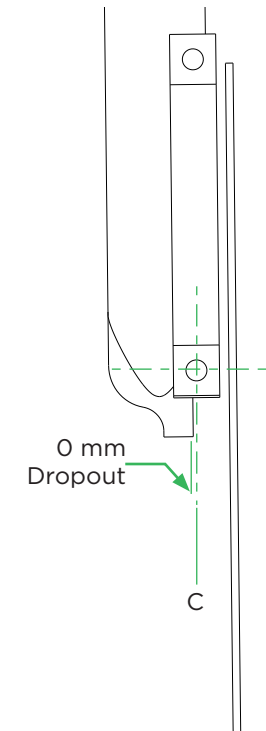

# SRAM CenterLine XR

## Two-piece Center Locking Rotor Dimensions

Rotor	Rotor Size	Radiused Outer Diameter		Rotor Thickness	Carrier Diameter
		A (mm)	B (mm)	B (mm)	C (mm)
CLX-R	140	140		1.90	100
	160	160		1.85	120

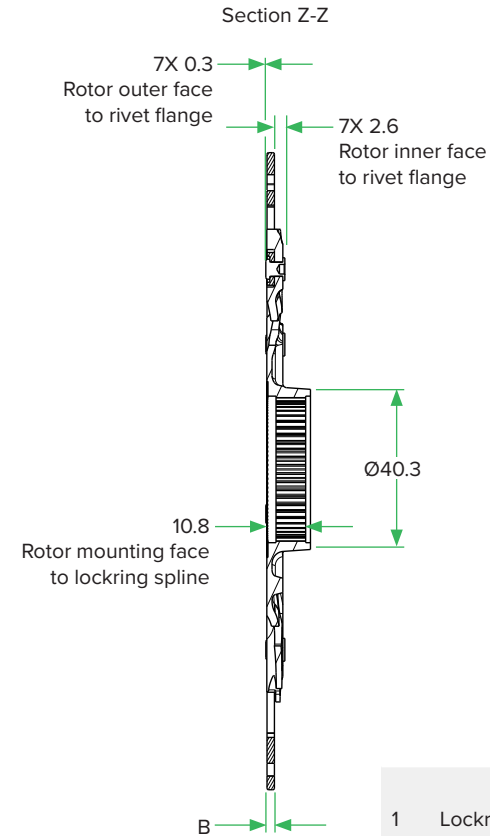
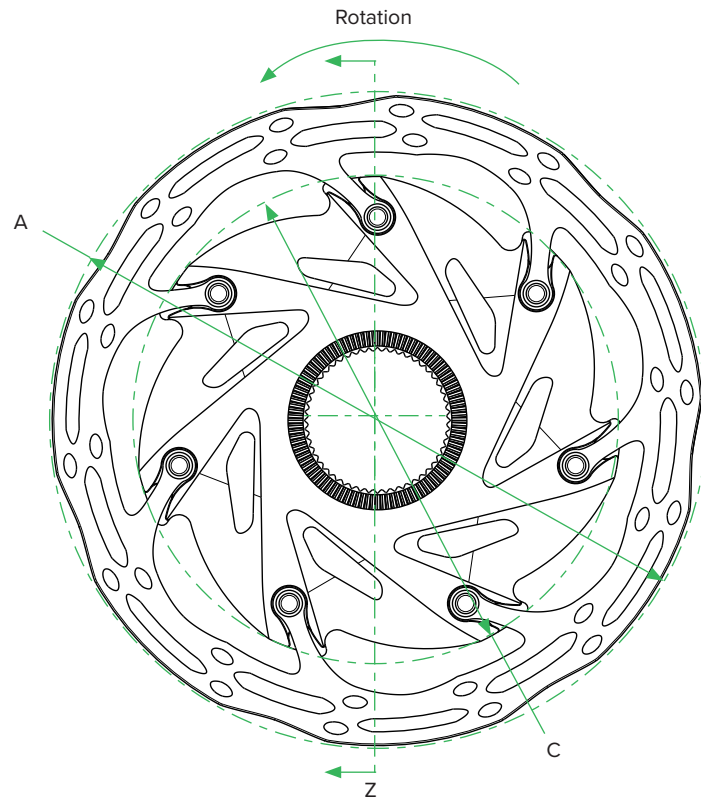

1 Locking torque to 40 N-m (354 in-lb).

# SRAM CenterLine X

## Two-piece Center Locking Rotor Dimensions

Rotor	Rotor Size	Radiused Outer Diameter	Rotor Thickness	Carrier Diameter
		A (mm)	B (mm)	C (mm)
CLX	140	140	1.90	90.1
	160	160	1.85	110.1

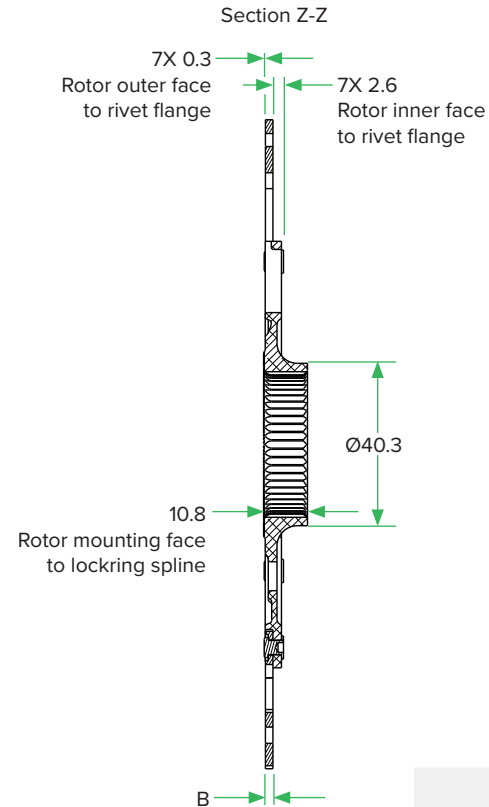
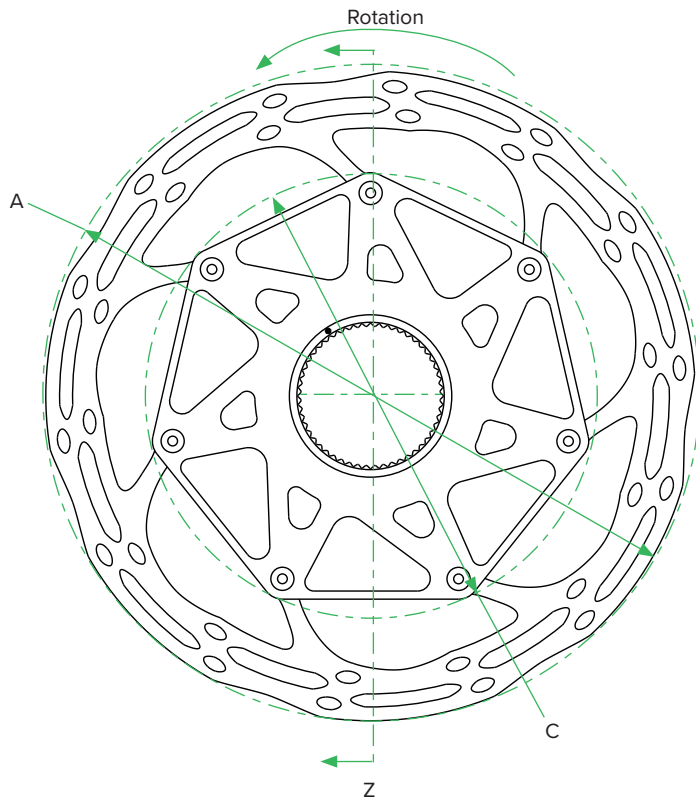

1 Lockring torque to 40 N-m (354 in-lb).



# SRAM CenterLine

## One-Piece Center Locking Rotor Dimensions

Rotor size	Radiused Outer Diameter	Rotor Thickness
	A (mm)	B (mm)
140 mm	140	1.85
160 mm	160	

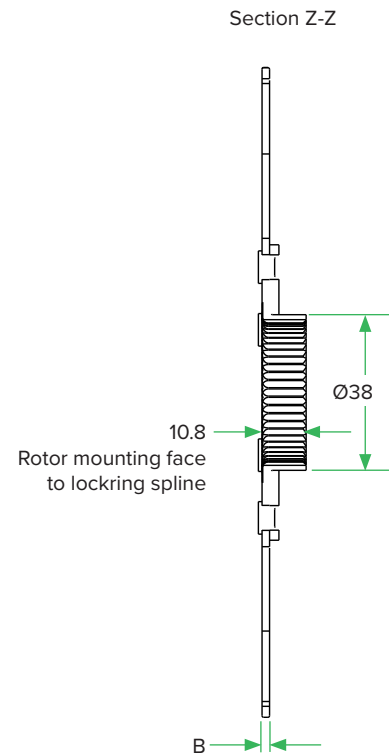
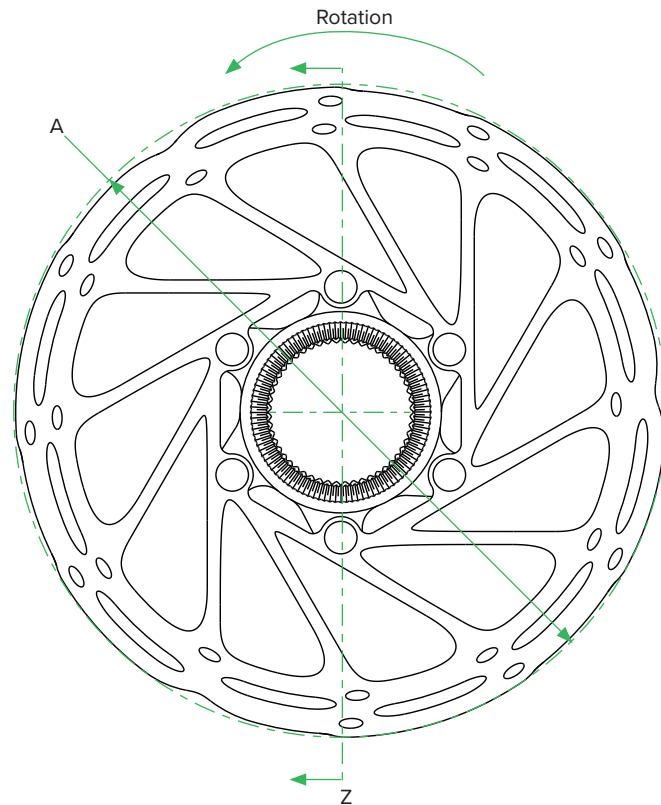

1 Locking torque to 40 N-m (354 in-lb).

# SRAM CenterLine XR

## Two-piece 6-Bolt Rotor Dimensions

Rotor	Rotor Size	Radiused Outer Diameter	Rotor Thickness	Carrier Diameter
		A (mm)	B (mm)	C (mm)
CLX-R	140	140	1.90	100
	160	160	1.85	120

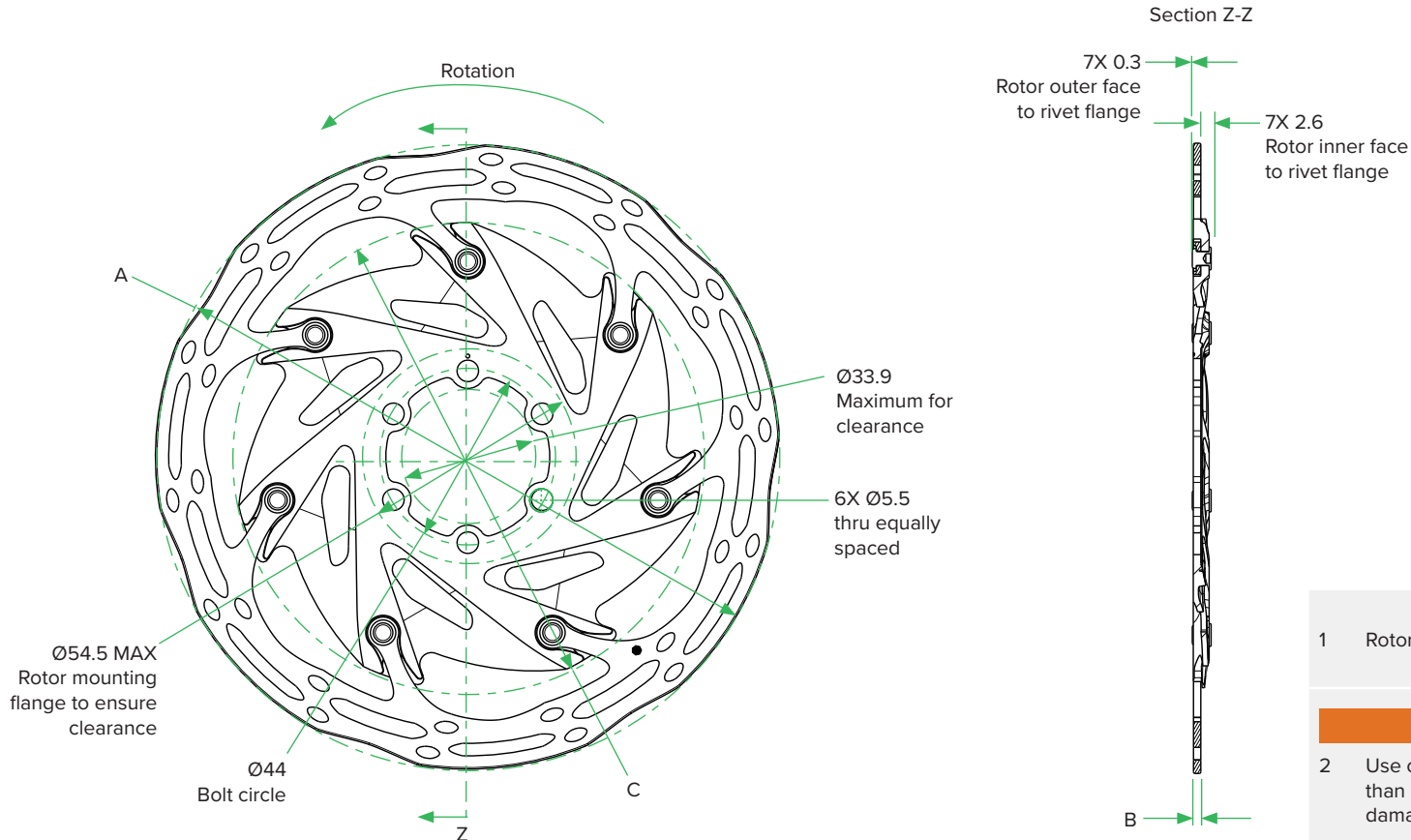

- 1 Rotor mounting bolt torque value is 6.2 N-m (55 in-lb).

### **⚠WARNING**

- 2 Use only 10 mm length rotor bolts. Rotor bolts longer than 10 mm will not properly secure rotor and could damage the hub.

# SRAM CenterLine X

## Two-piece 6-Bolt Rotor Dimensions

Rotor	Rotor Size	Radiused Outer Diameter	Rotor Thickness	Carrier Diameter
		A (mm)	B (mm)	C (mm)
CLX	140	140	1.90	90.1
	160	160	1.85	110.1

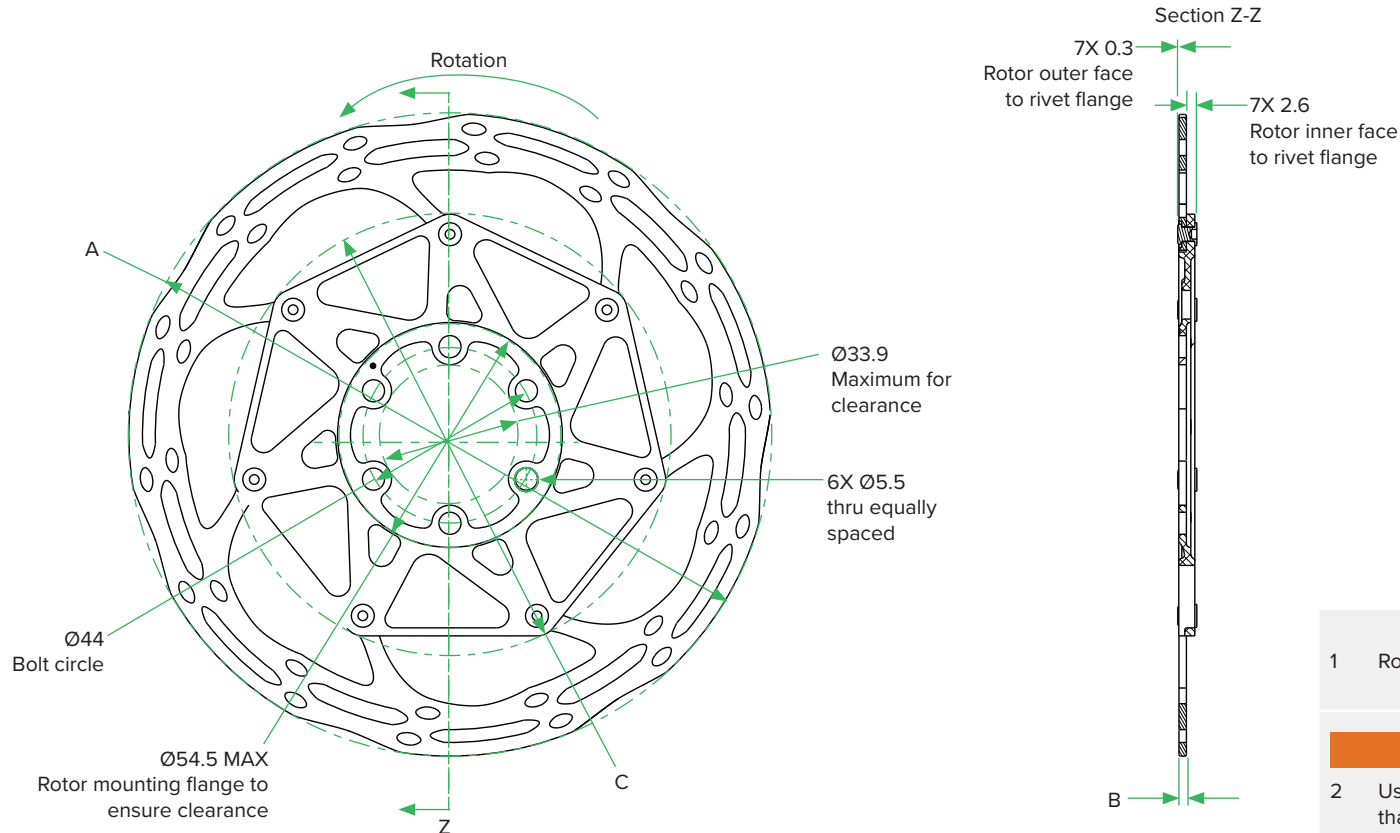

1 Rotor mounting bolt torque value is 6.2 N-m (55 in-lb).

### **WARNING**

2 Use only 10 mm length rotor bolts. Rotor bolts longer than 10 mm will not properly secure rotor and could damage the hub.

# SRAM CenterLine

## One-piece 6-Bolt Rotor Dimensions

Rotor size	Rotor Thickness	
	Radiused Outer Diameter	B (mm)
	A (mm)	
140 mm	140	1.85
160 mm	160	

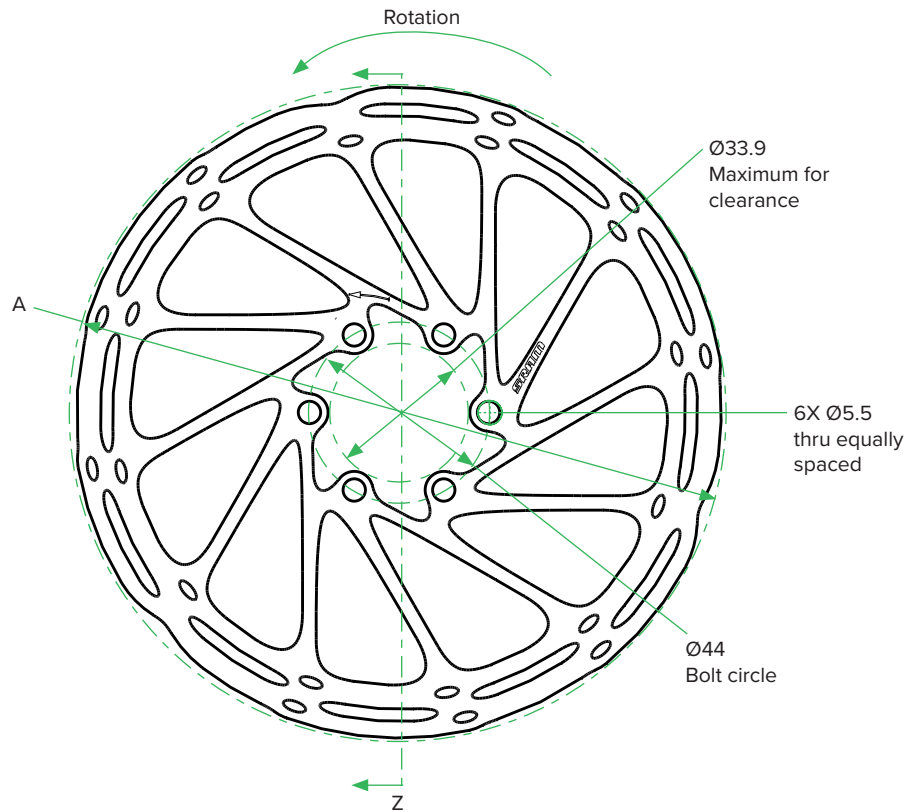

Section Z-Z

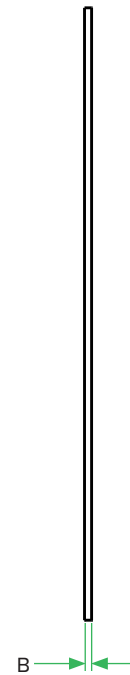

- 1 Rotor mounting bolt torque value is 6.2 N-m (55 in-lb).

### **⚠️WARNING**

- 2 Use only 10 mm length rotor bolts. Rotor bolts longer than 10 mm will not properly secure rotor and could damage the hub.

# Spoke Clearance

## Road Disc Brakes

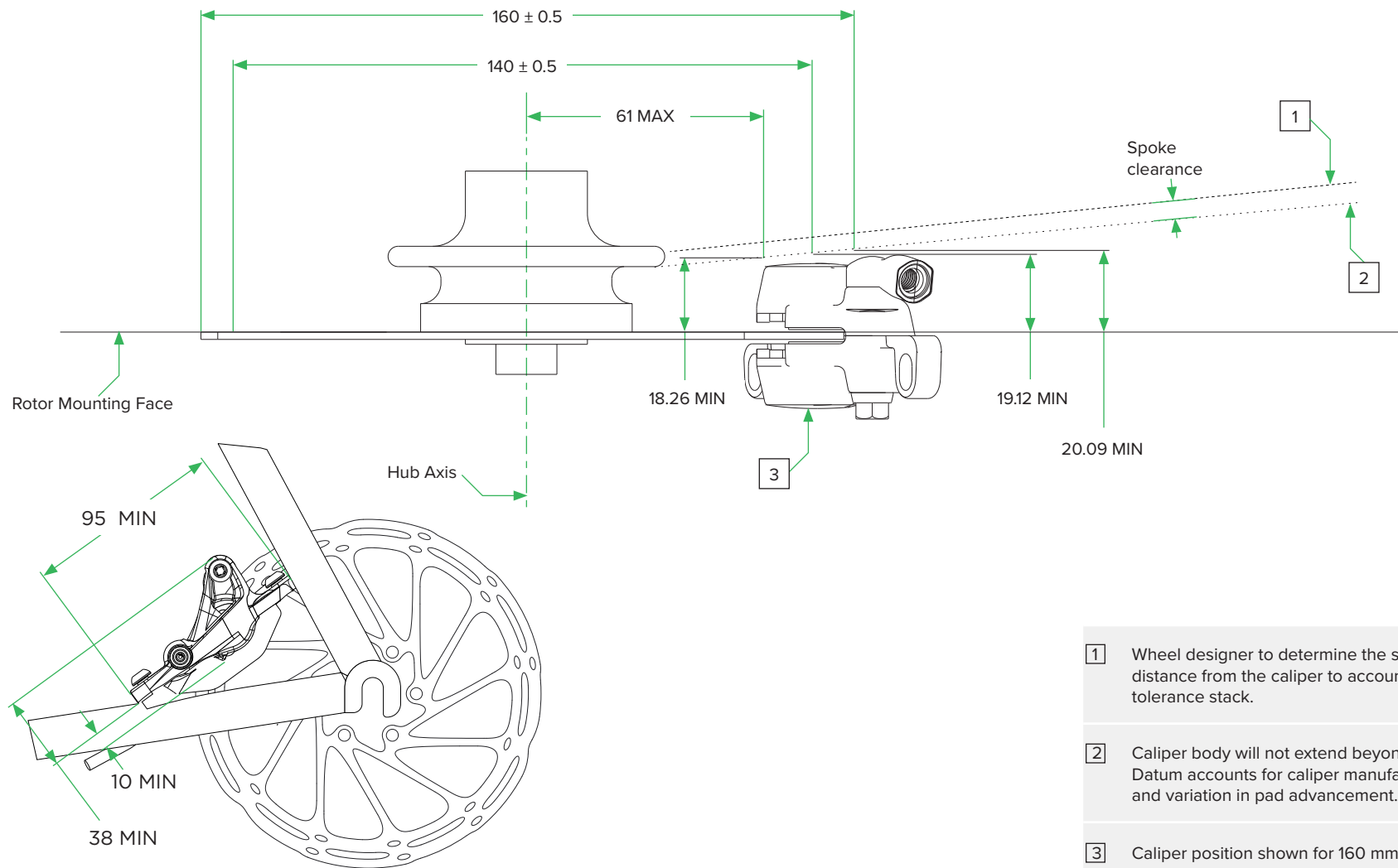

- 1 Wheel designer to determine the safe clearance distance from the caliper to account for wheel flex and tolerance stack.
- 2 Caliper body will not extend beyond this datum. Datum accounts for caliper manufacturing tolerances and variation in pad advancement.
- 3 Caliper position shown for 160 mm rotor.

# Dropbar Guidelines

Road Electronic Shift-Brake

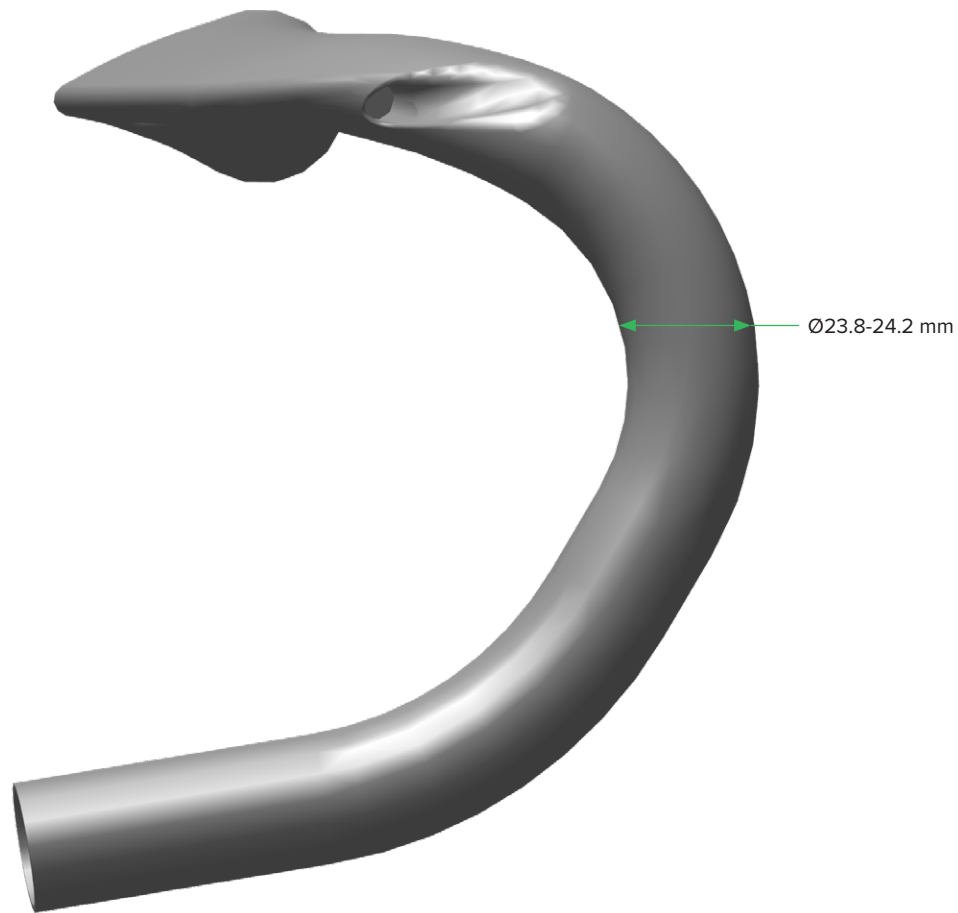

# S-900 Aero HRD

## Hydraulic Aero Brake Lever Bar Guidelines

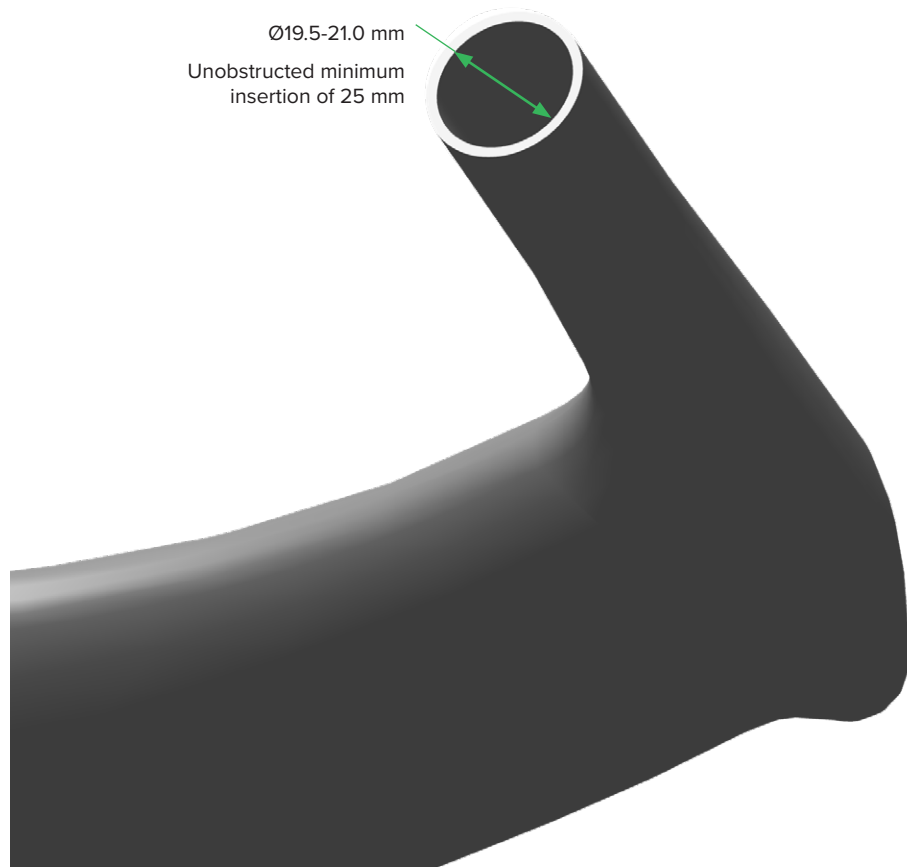

# BB7/ BB5 Road

## Mechanical Disc Brake Clearance

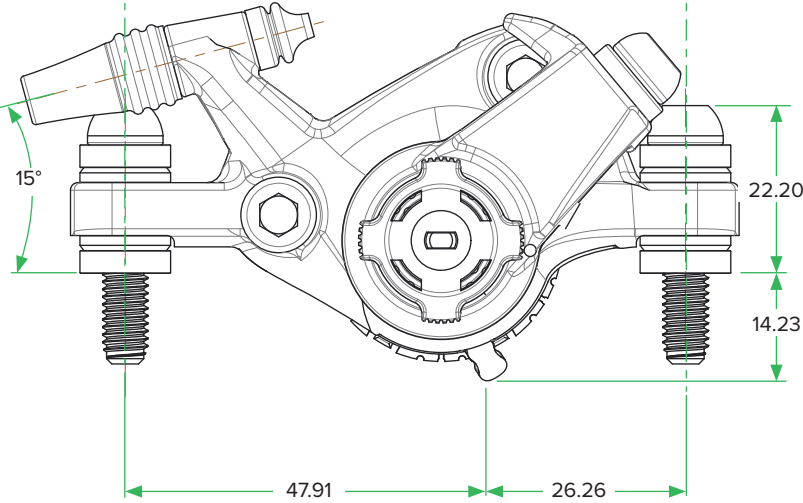
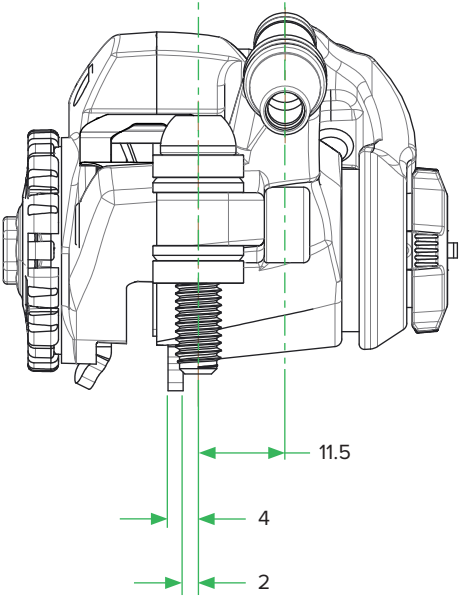



# Front Rim Brake Caliper

## Direct Mount and Single Pivot Design Dimensions

Brake Caliper Pivot Location

700 C	A		-30	0	25	50
	B ±2	SRAM DM Front	335.9	339	339.5	338
	SRAM SP Front	349	353.5	355	354.5	

- 1 For increased tire clearance, make mounting features to the + side of the "B" dimension tolerance limit.
- 2 For 650c wheels, subtract 26 mm from the 700c "B" dimensions.
- 3 Mount only to the front side of the fork.

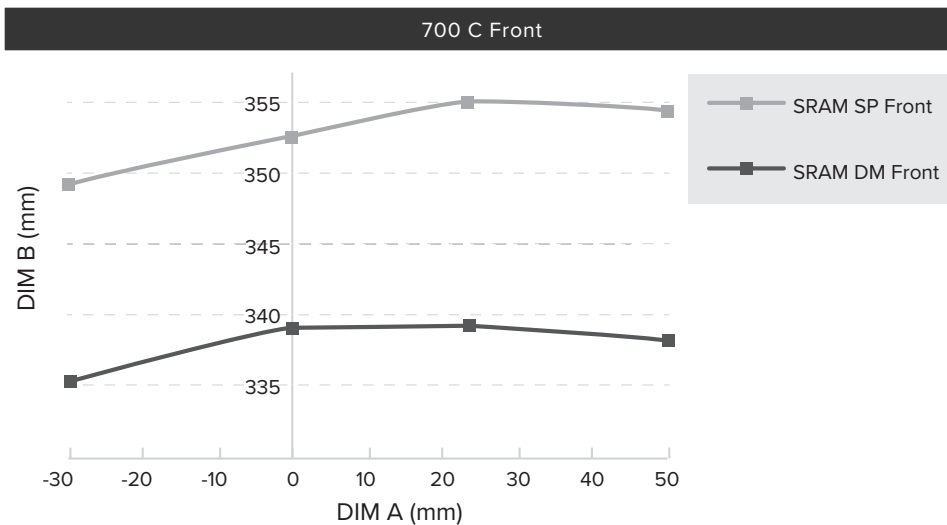

Direct Mount Front Rim Brake Caliper

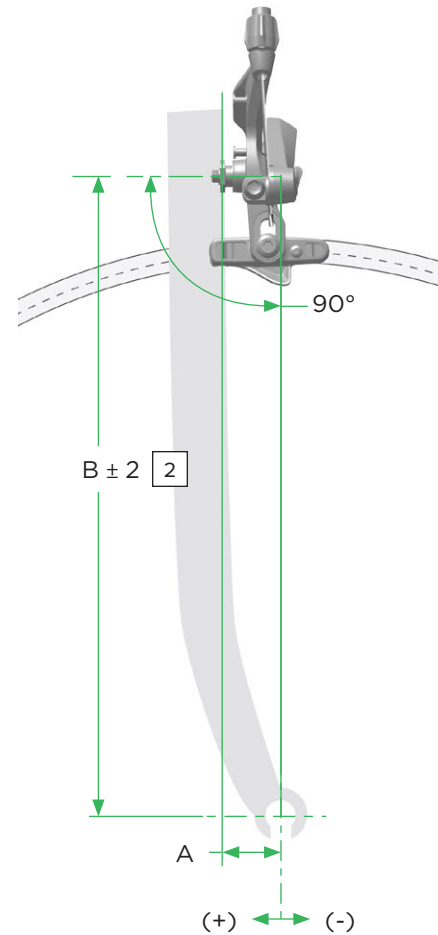

Single Pivot Front Rim Brake Caliper

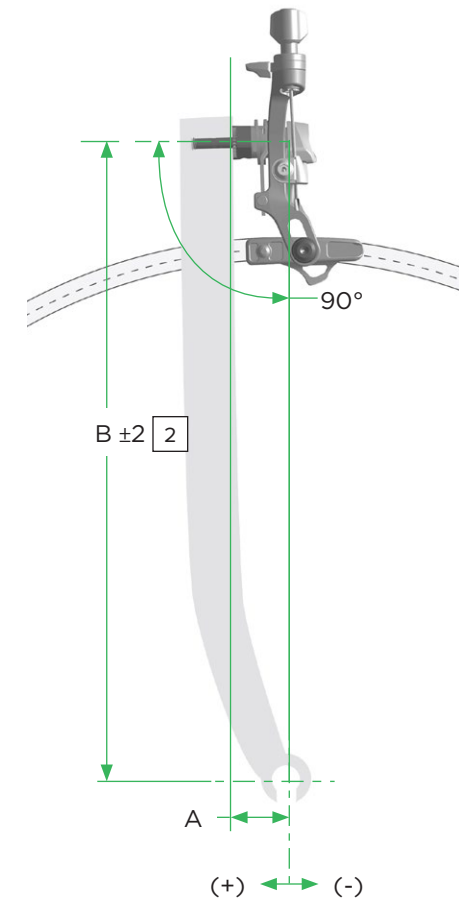

# Rear Rim Brake Caliper

## Direct Mount and Single Pivot Design Dimensions

Brake Caliper Pivot Location

700 C	A		-30	0	25	50
	B ±2	SRAM DM Front	335.9	339	339.5	338
	SRAM SP Front	349	353.5	355	354.5	

- 1 For increased tire clearance, make mounting features to the + side of the "B" dimension tolerance limit.
- 2 For 650c wheels, subtract 26 mm from the 700c "B" dimensions.
- 3 Mount only to the back side of the seatstay. Do not mount under bottom bracket or on the front side of the seatstay.

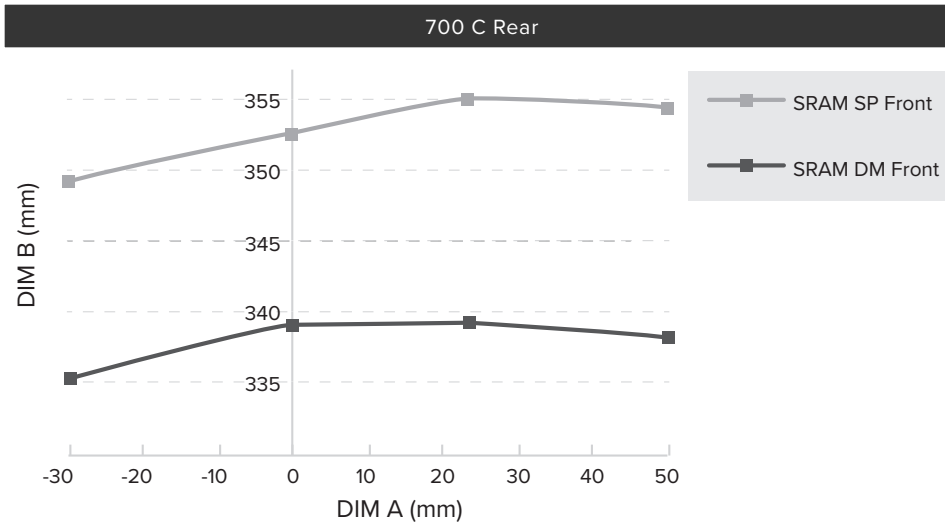

Direct Mount Rear Rim Brake Caliper

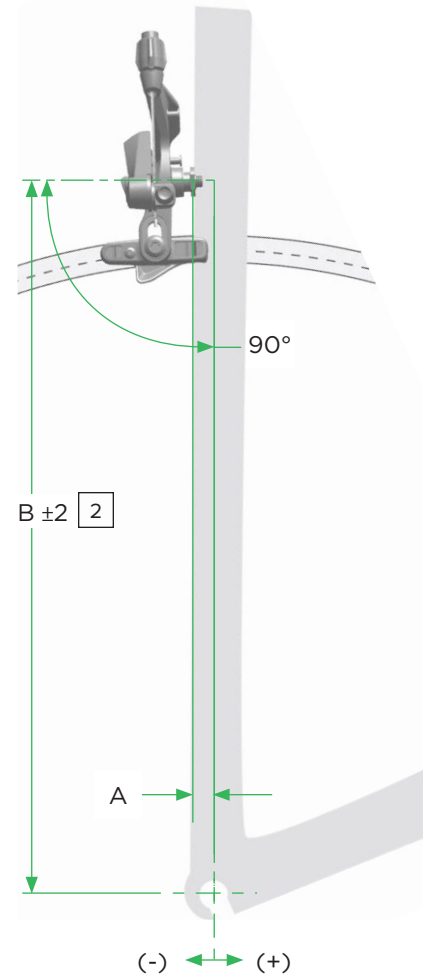

Single Pivot Rear Rim Brake Caliper

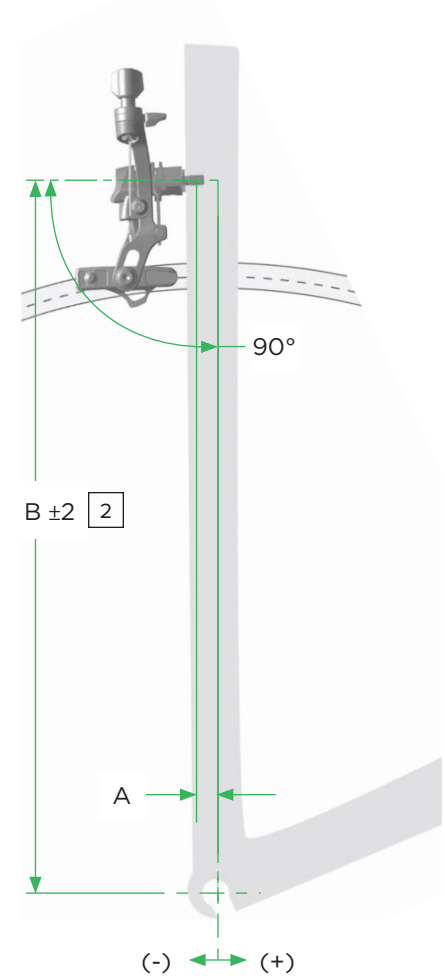

# Front Direct Mount

## Mounting Dimensions

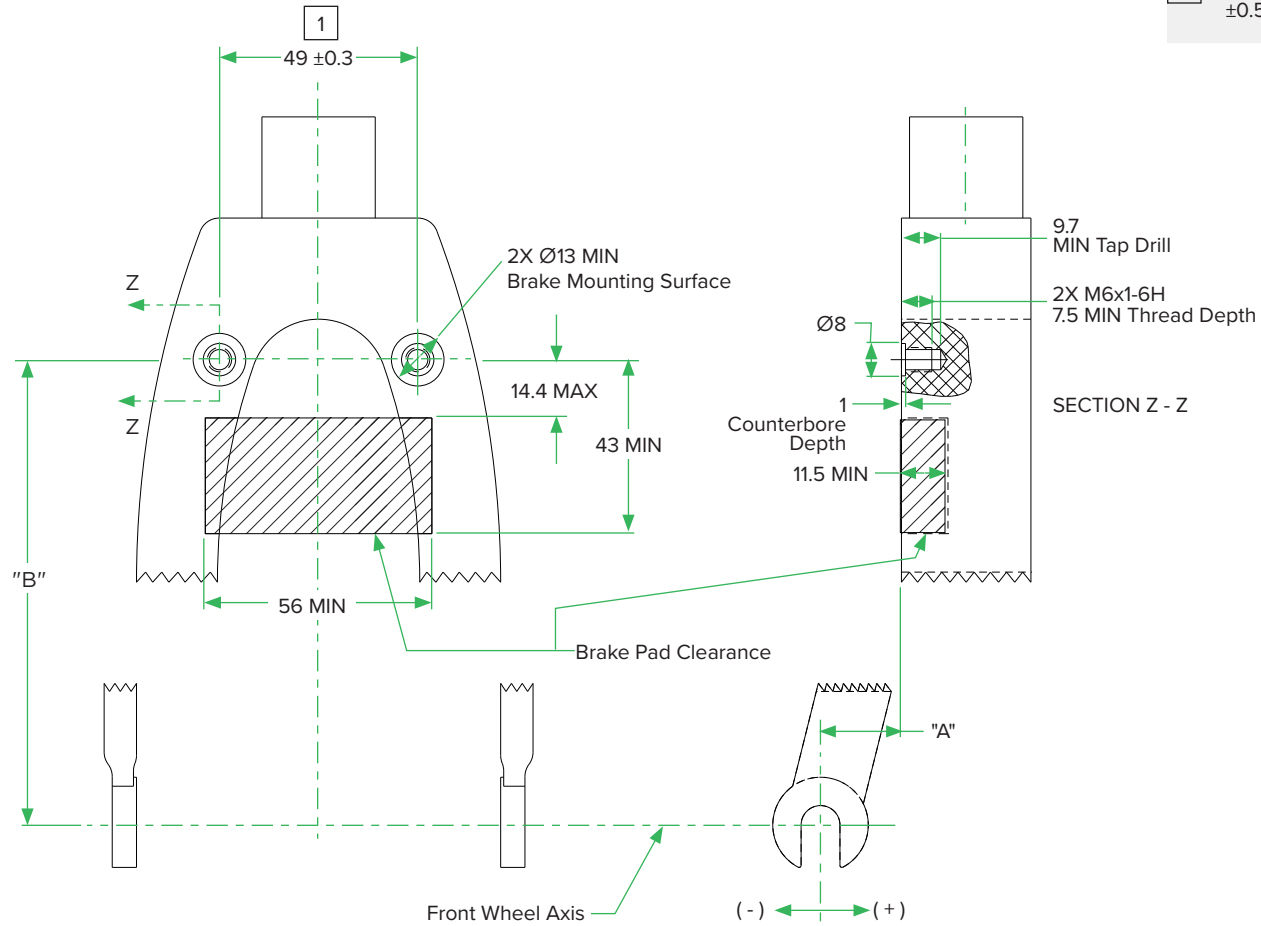

1 Center the posts between the dropouts within  $\pm 0.5$  mm.

# Rear Direct Mount Mounting Dimensions

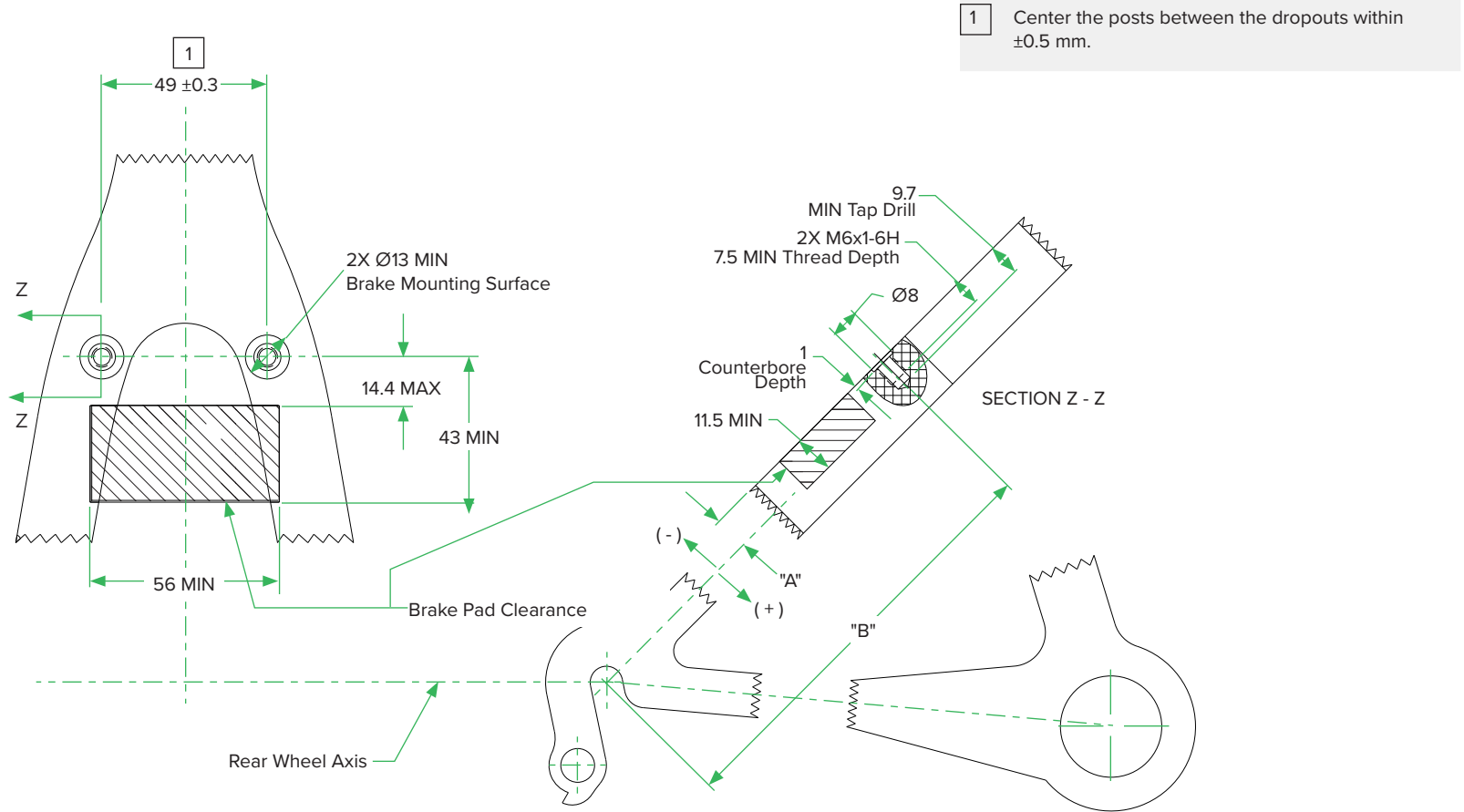

# Direct Mount

## Rim Brake Caliper Design Dimensions

Front Rim Brake Caliper

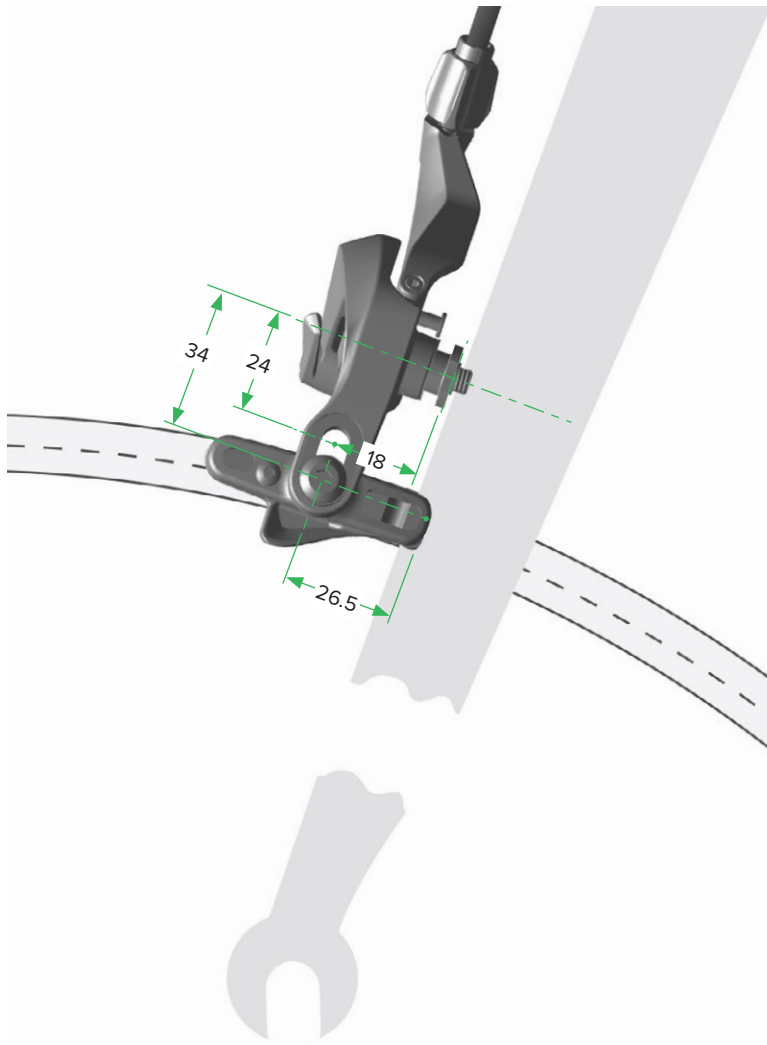

Rear Rim Brake Caliper

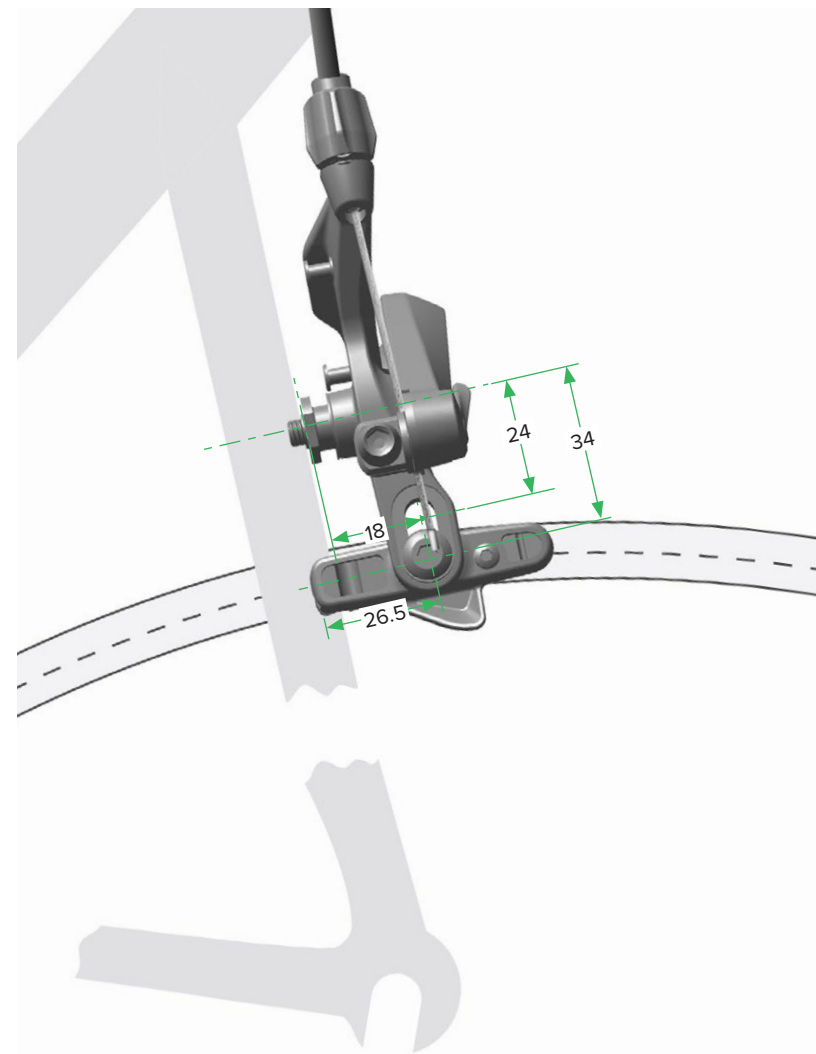

# Single-Post Mount

## Rim Brake Caliper Design Dimensions

Front Rim Brake Caliper

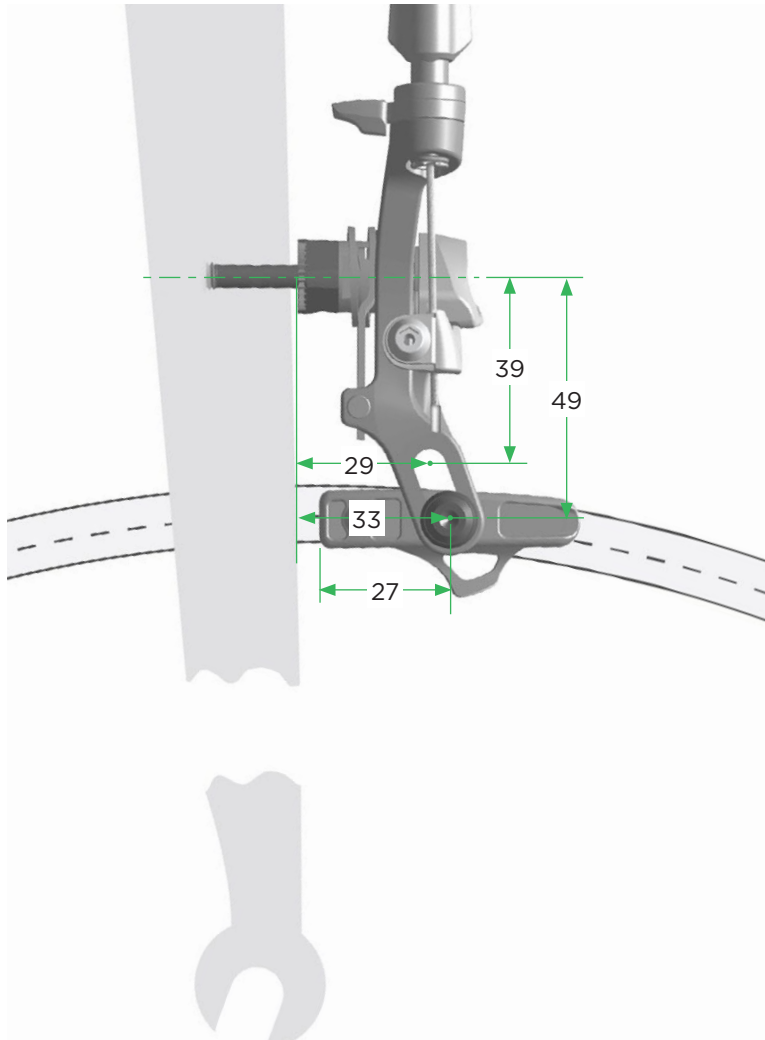

Rear Rim Brake Caliper

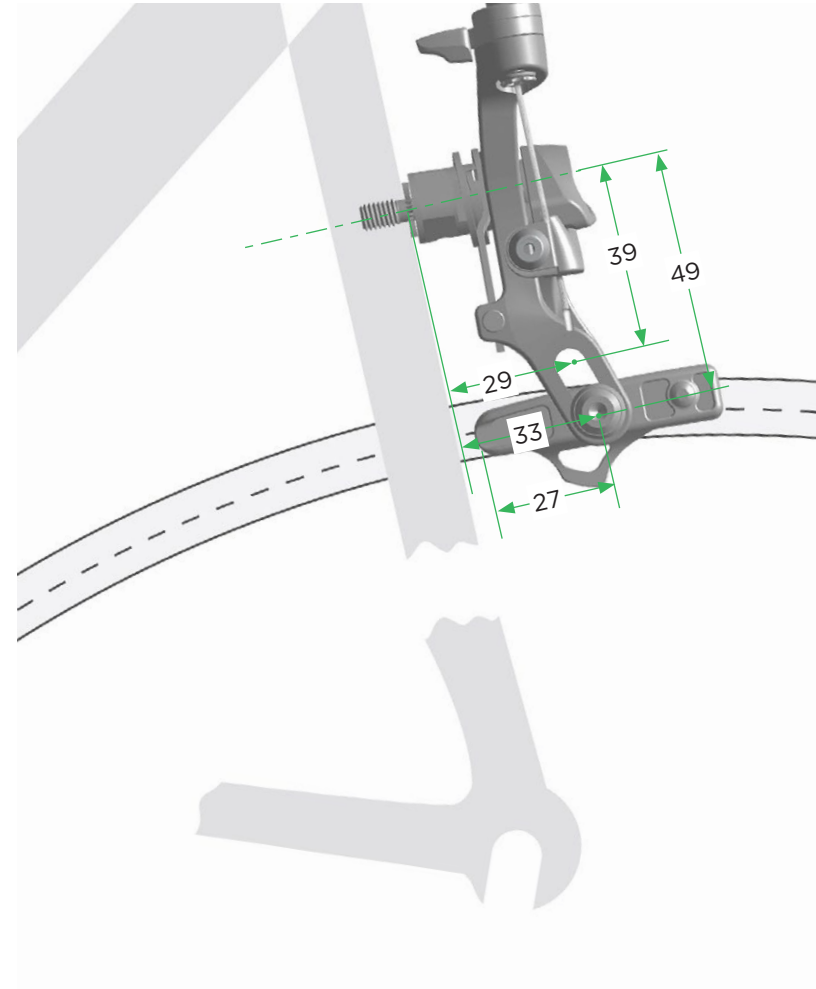

# Shorty Ultimate

## Dual Mounted Brake Caliper

1 For wheel rims wider than 23 mm, consult the spare parts catalog on [www.sram.com/service](http://www.sram.com/service) for part numbers.

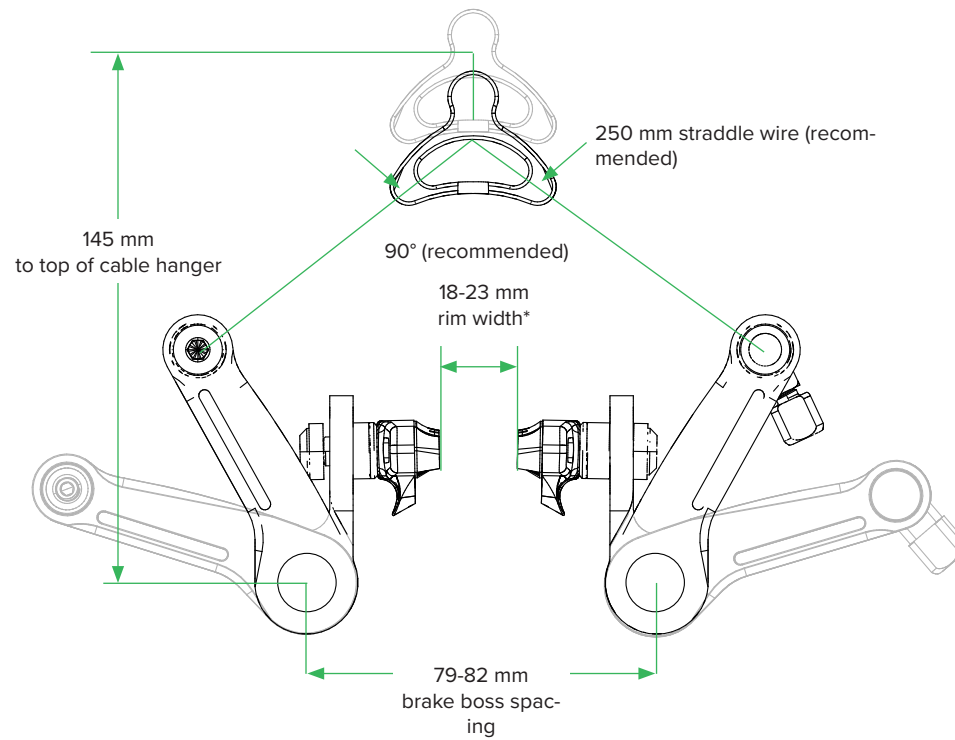

# Shorty 6/ Shorty 4

## Cable Carrier and Straddle Cable Length

	Length of straddle cable	Opening angle of straddle cable	Designed width of Shorty	Total height	Designed height	Total width	Pivot width	Opening
	A (mm)	C	D (mm)	H (mm)	h (mm)	W (mm)		
CCC Type S	63	100°	31.78	92.94	56.80	51.61	63.21	39.65
CCC Type A	73	95°		106.12		53.82	67.64	44.08
CCC Type B	82	87°		116.28		56.45	72.89	49.33
CCC Type C	106	80°		138.00		68.14	96.27	72.71
CCC Type D	93	90		122.56		65.76	91.52	67.96

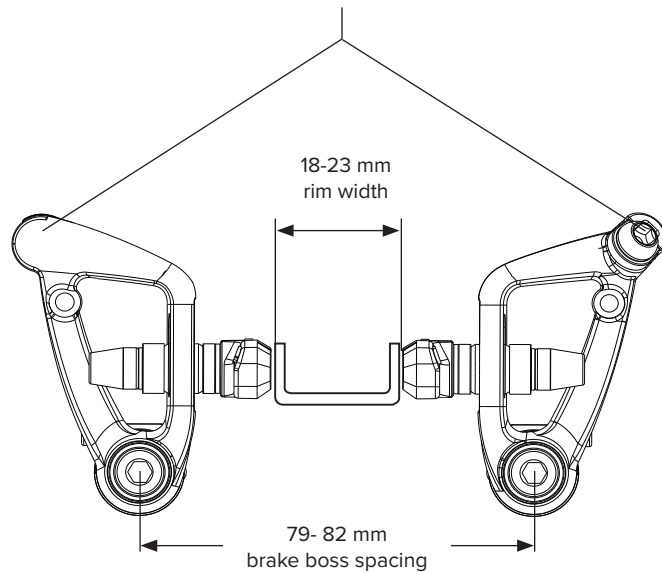



# Wheels and Hubs

# Zipp Wheels

## Rim/Disc Design Parameters

	MAX Width	Depth at MAX Width	MAX Depth	Radius to Center Axis
	A (mm)	B (mm)	C (mm)	R1 (mm)
30 Course CC	25	10.00	26.00	316.60
30 Course TU				316.25
30 Course CC DB		5.45		316.60
30 Course TU DB				316.25
202 Firecrest & NSW CC	25.65	13.01	32.54	316.62
202 TU	22.86	8.23		
202 Firecrest & NSW Tubeless DB	28.65	8.42	32.00	316.67
302 CC RB & DB	26.50	14.89	26.50	326.45
303 Firecrest & 303 NSW CC	28.25	19.45	46.60	316.62
303 NSW Tubeless DB	29.88	21.90	45.50	316.67
303 Firecrest 650b Tubeless DB				297.95
303 Firecrest Tubeless DB				316.67
303 Firecrest TU	28.25	19.08	46.60	316.62
404 Firecrest & NSW CC	27.8	26.06	58.75	
404 Firecrest TU	27.32	25.13		
404 Firecrest & NSW Tubeless DB	26.99	19.84	58.75	316.73
808 Firecrest & 808 NSW CC	27.8	50.05	81.82	316.62
808 Firecrest & NSW Tubeless DB	28.02	35.10	82.50	316.66
808 Firecrest TU	27.17	49.77	81.82	316.62
900 TU DB	21.28	NA	NA	
Super-9 CC DB	28.25			
Super-9 TU DB				

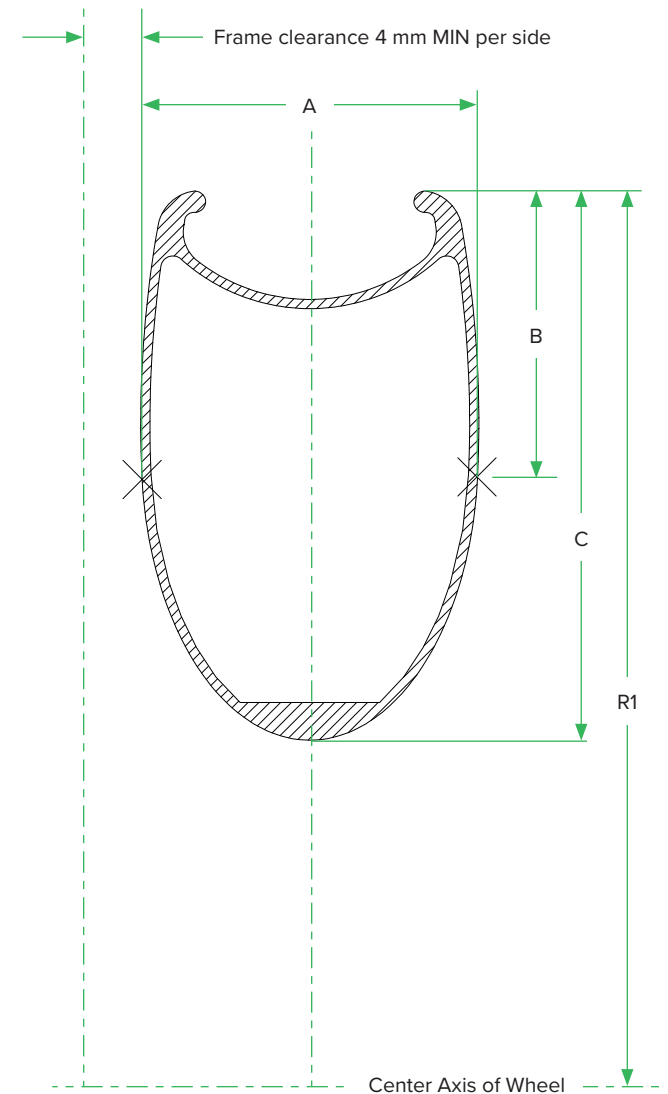

# Rear Derailleur Wheel Spoke Clearance

XDR

1 Refer to <http://xddriverbody.com/> for freehub driver body specifications.

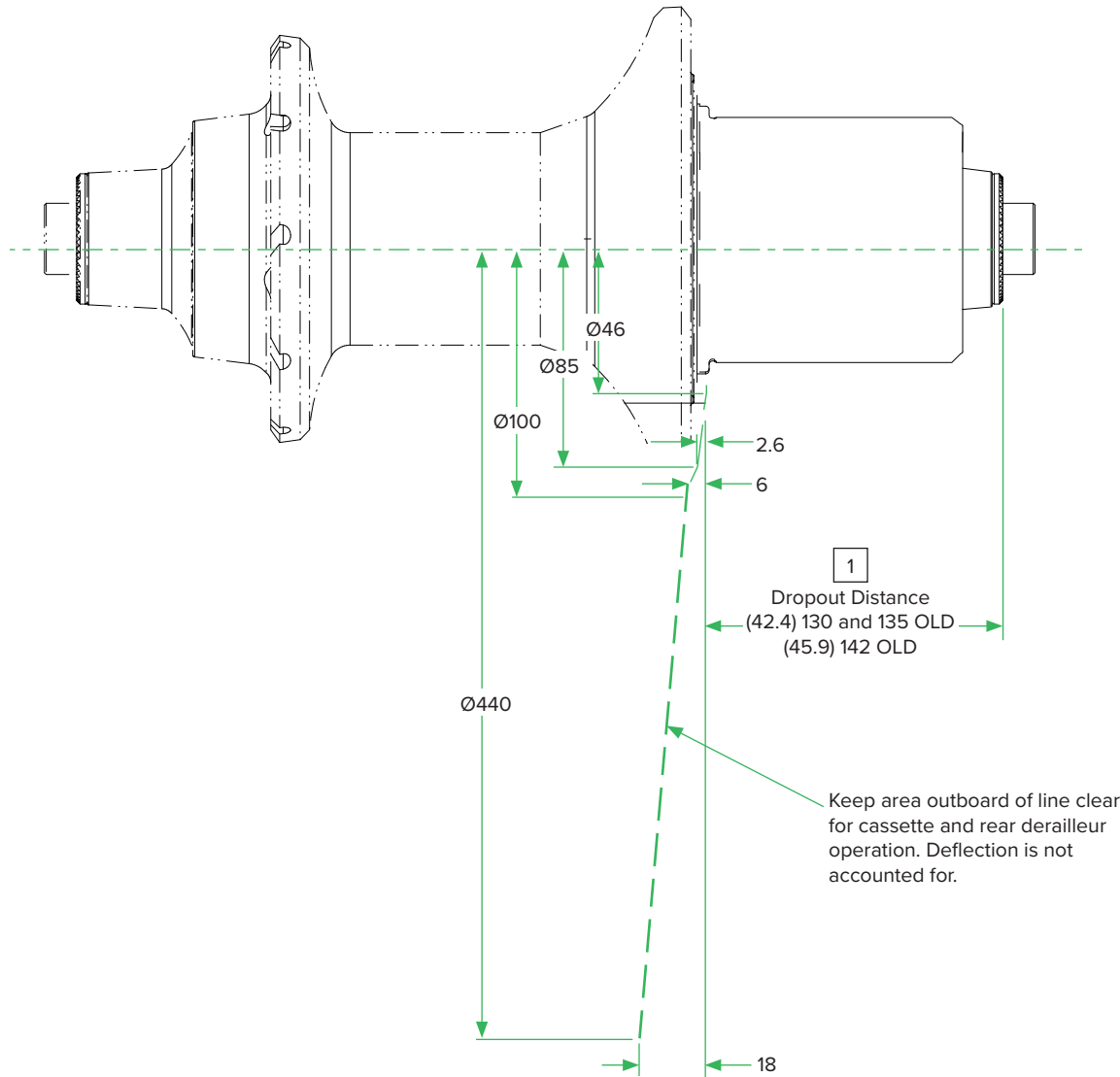

# Driver and Wheel Standard

10 and 11 speed

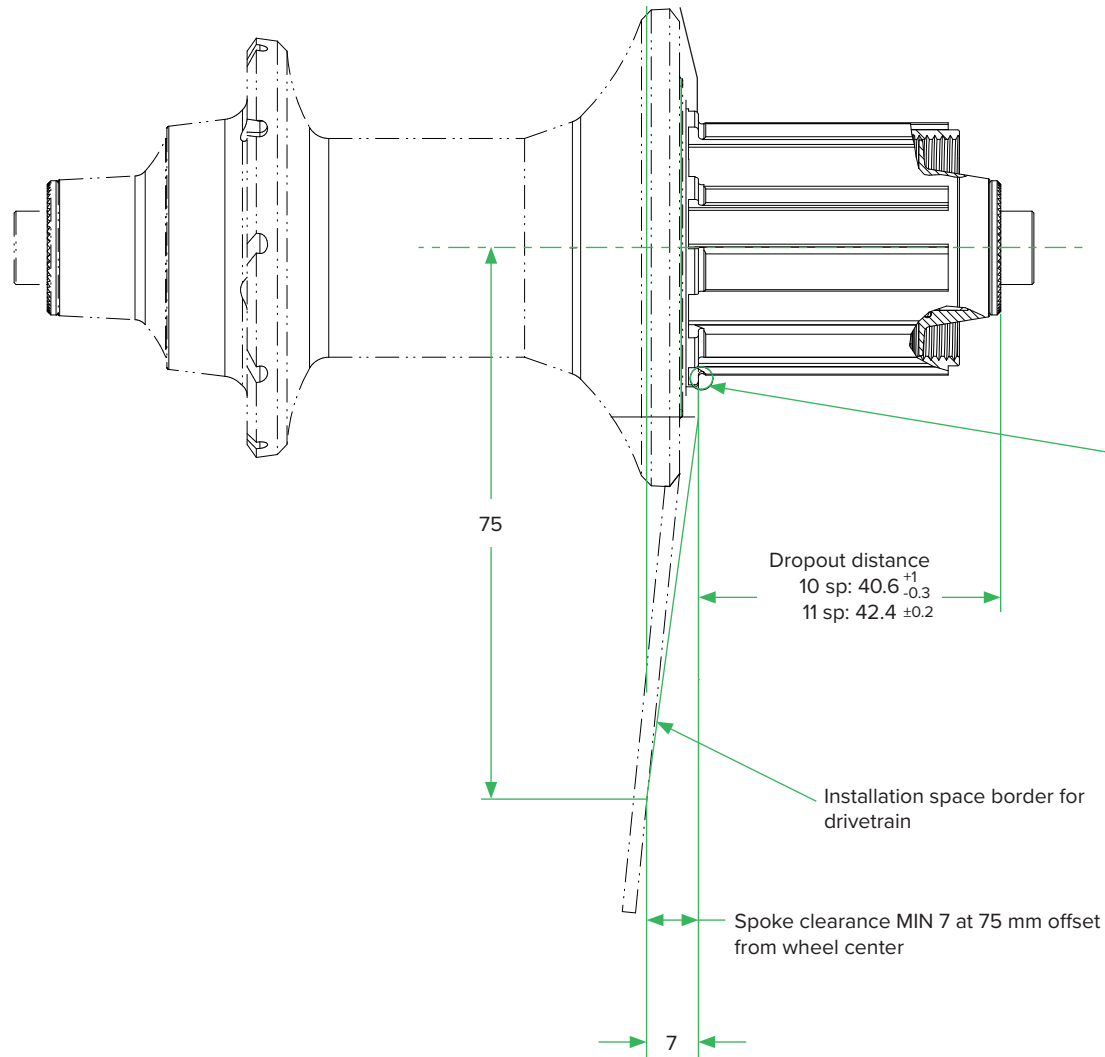

See Detail A

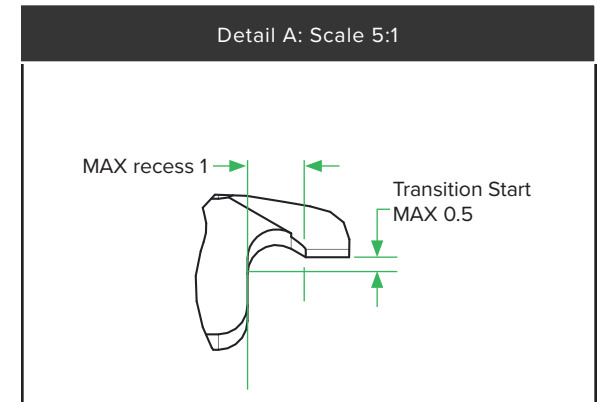

# Driver and Wheel Standard

10 and 11 speed

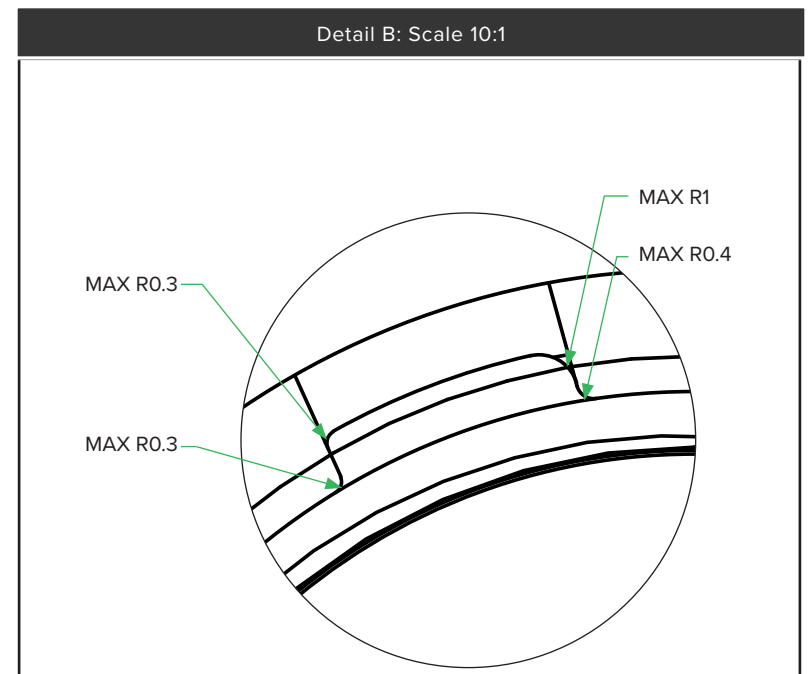
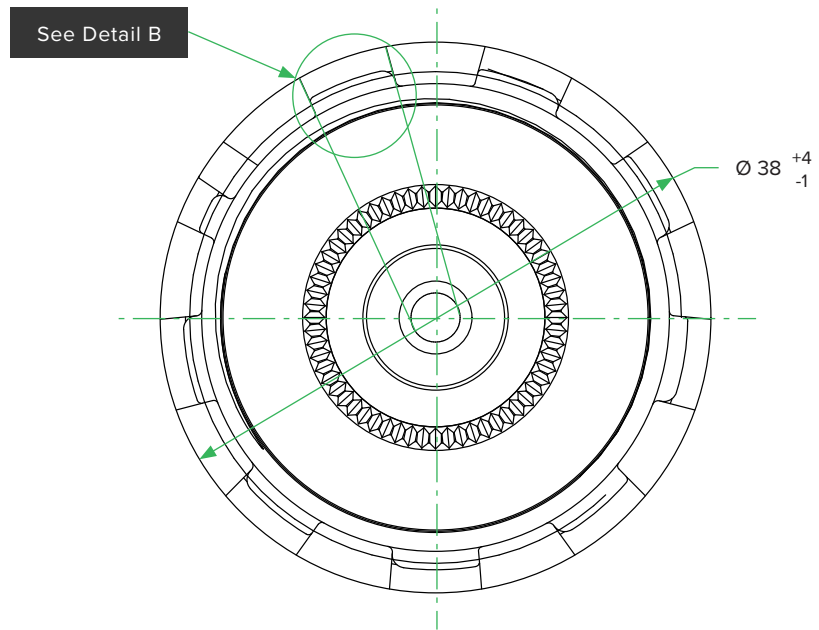

# Zipp Hubs with Center Locking Disc Brake Mount

## Front Hub Specifications

	A (mm)	B (mm)	C (mm)	E (mm)
9x10 Quick Release Hub	100.0 ± 0.75	Ø 5.3 ± 0.1	Ø 19.5 ± 0.1	Ø 8.85 ± 0.05
12x100 Thru Axle Hub		Ø 12.0 ± 0.1	Ø 18.7 ± 0.1	N/A
15x100 Thru Axle Hub		Ø 15.0 ± 0.1		

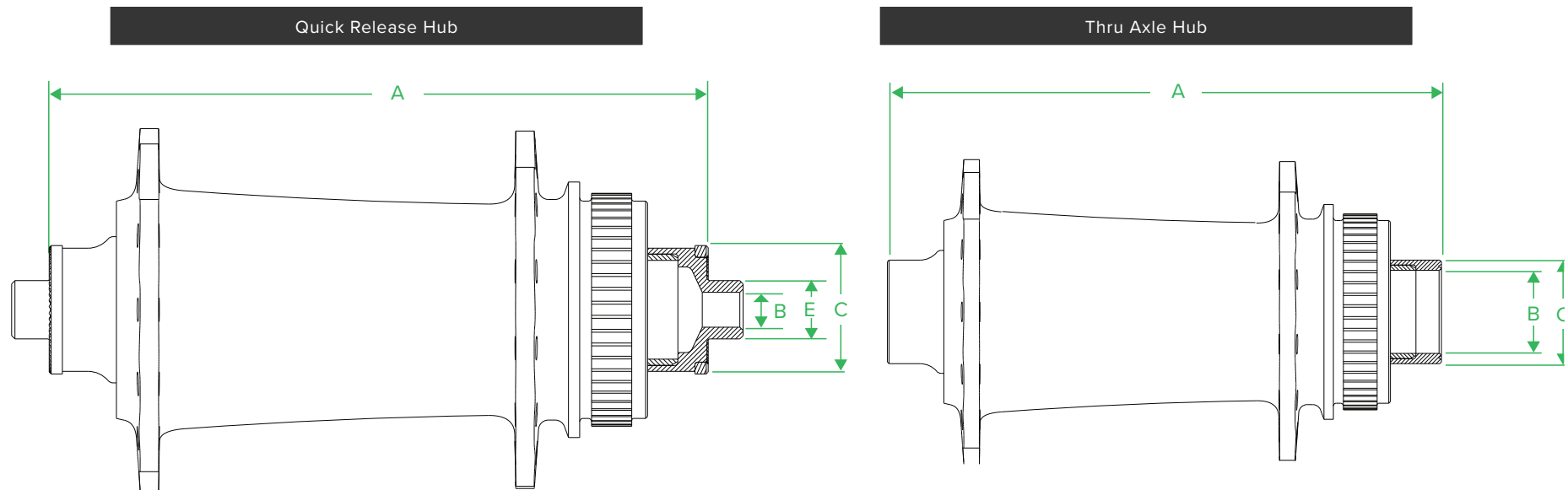

# Zipp Hubs with Center Locking Disc Brake Mount

## Rear Hub Specifications

	A (mm)	B (mm)	C (mm)	E (mm)	F (mm)
10x135 Quick Release Hub	135.0 ± 0.5	∅ 5.3 ± 0.1	∅ 19.5 ± 0.1	∅ 9.85 ± 0.05	42.4 ± 0.2
12x135 Thru Axle Hub		∅ 12.0 ± 0.1	∅ 18.7 ± 0.1	N/A	
12x142 Thru Axle Hub	142.0 ± 0.5				45.9 ± 0.2

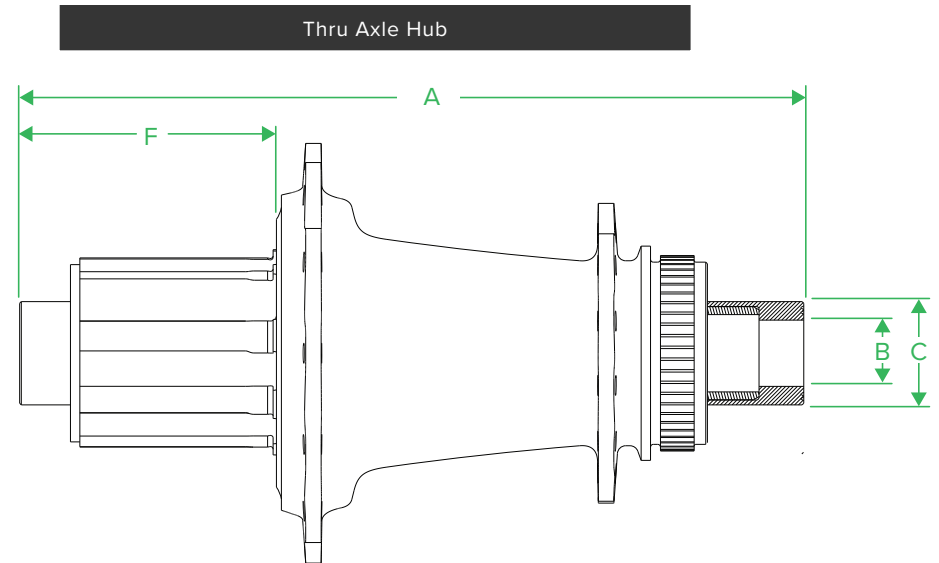
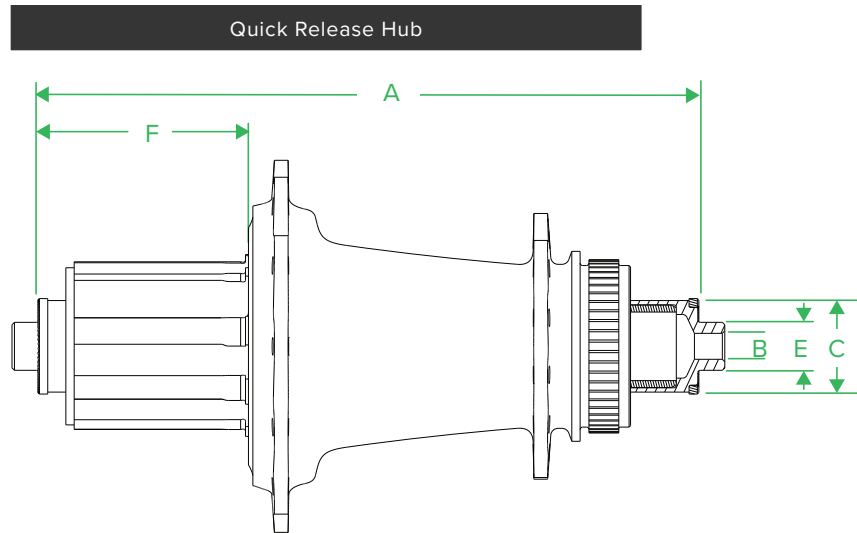

# Zipp Hubs with Center Locking Disc Brake Mount

Front and Rear Hub Distance to Rotor

	D (mm)		E (mm)	
	CLX	CLX-R	CLX	CLX-R
9x10 Quick Release Hub	19.5	CLX-R	8.5	9.0
12x100 Thru Axle Hub				
15x100 Thru Axle Hub				
10x135 Quick Release Hub	24.25	CLX-R	8.5	9.0
12x135 Thru Axle Hub				
12x142 Thru Axle Hub	27.25	CLX-R	8.5	9.0

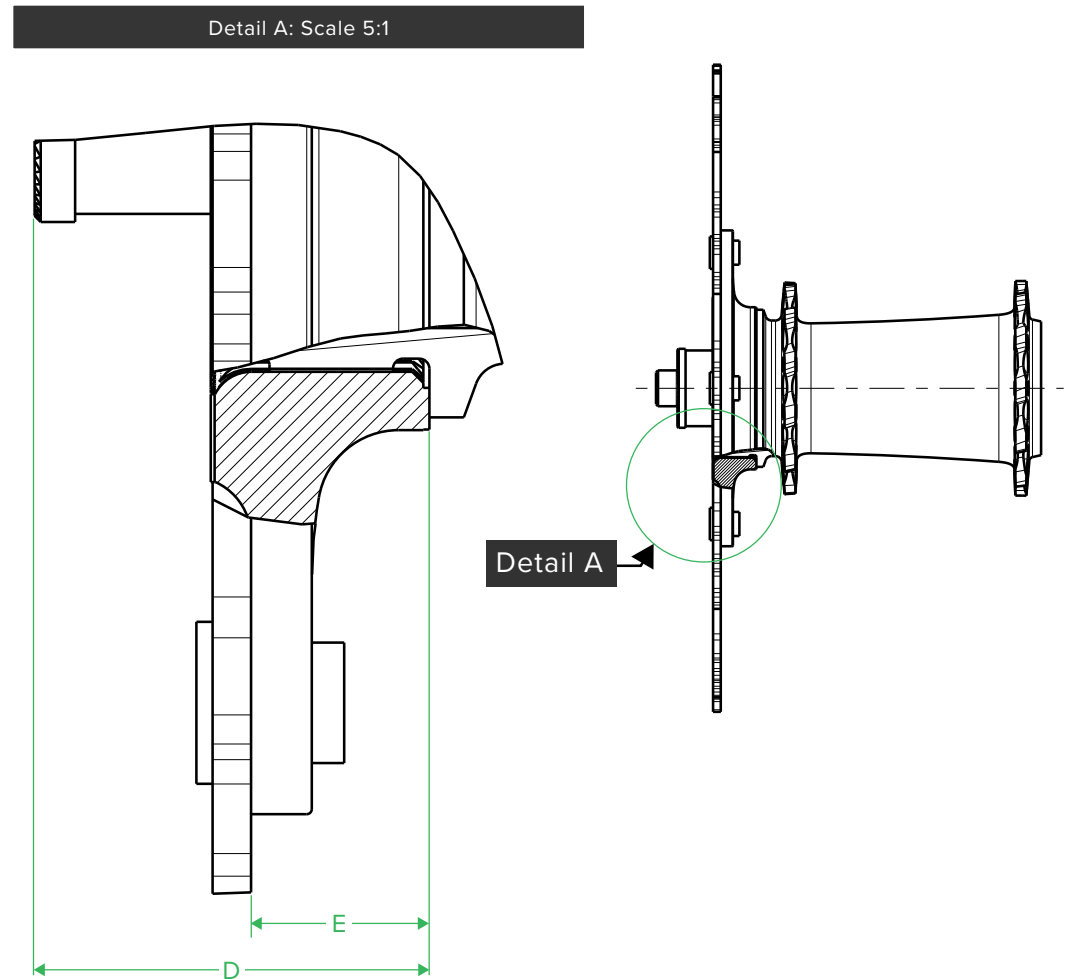



# Zipp Hubs with ISO 6 Bolt Disc Brake Mount

## Front Hub Specifications

	A (mm)	B (mm)	C (mm)	D (mm)	E (mm)
9x100 Quick Release Hub	100.0 ± 0.75	∅ 5.3 ± 0.1	∅ 19.5 ± 0.1	10.5 ± 0.3	∅ 8.85 ± 0.05
12x100 Thru Axle Hub		∅ 12.0 ± 0.1	∅ 19.0 ± 0.1		N/A
15x100 Thru Axle Hub		∅ 15.0 ± 0.1	∅ 19.5 ± 0.1		
9x100 Thru-bolt Hub		∅ 9.0 ± 0.1			

Quick Release Hub

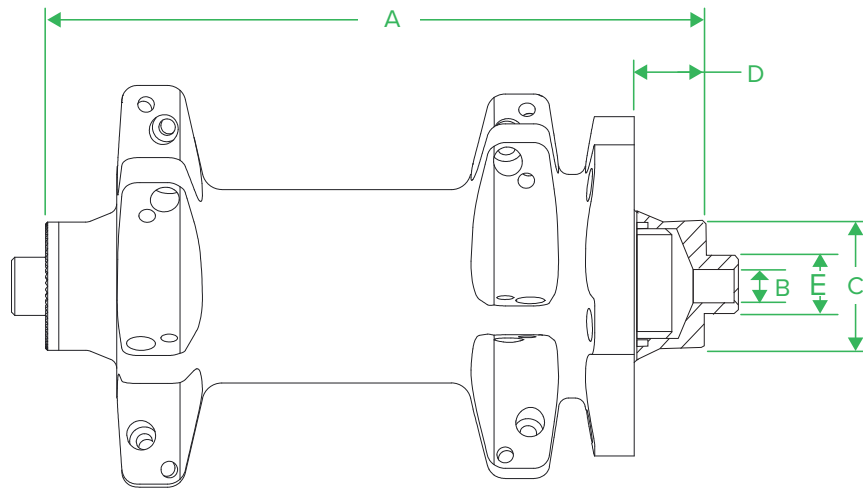

Thru Axle and Thru-bolt Hub

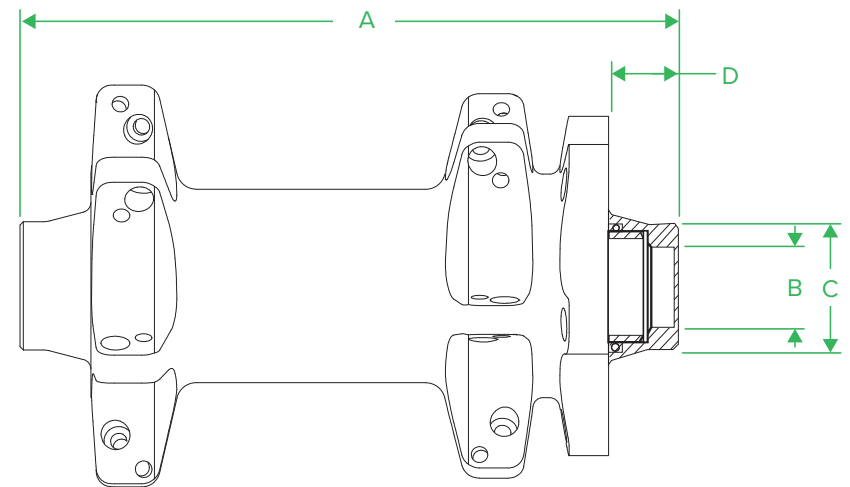

# Zipp Hubs with ISO 6 Bolt Disc Brake Mount

## Rear Hub Specifications

	A (mm)	B (mm)	C (mm)	D (mm)	E (mm)	F (mm)
10x135 Quick Release Hub	135.7 ± 0.3/-1.0	∅ 5.3 ± 0.1	∅ 19.5 ± 0.1	15.5 ± 0.2	∅ 9.85 ± 0.05	42.4 ± 0.2
12x135 Thru Axle Hub		∅ 12.0 ± 0.1	∅ 19.0 ± 0.1			
12x142 Thru Axle Hub	142.7 ± 0.3/-1.0	∅ 10.0 ± 0.1	∅ 19.5 ± 0.1	19.0 ± 0.2	N/A	45.9 ± 0.2
10x135 Thru-bolt Hub	135.7 ± 0.3/-1.0			15.5 ± 0.2		42.4 ± 0.2

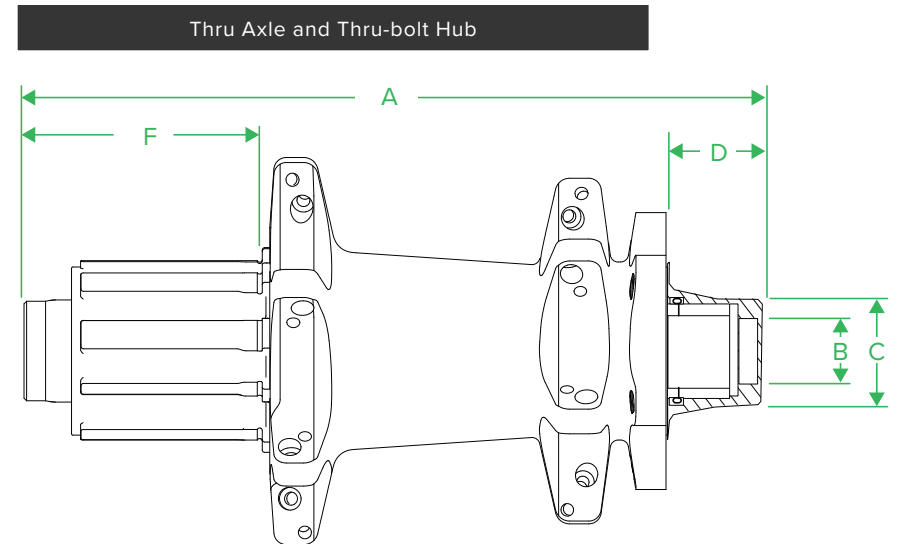
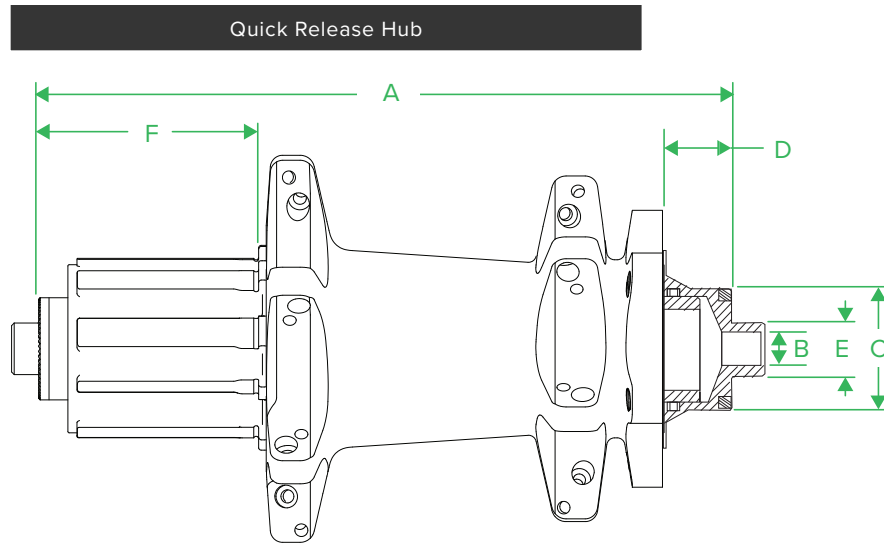

# Zipp Rim Brake Hubs

## Front Hub Specifications

	A (mm)	B (mm)	C (mm)	E (mm)
9x100 Quick Release Hub	$100 \pm 0.75$	$\text{Ø } 5.3 \pm 0.1$	$\text{Ø } 18.3 \text{ MAX}$	$\text{Ø } 8.85 \pm 0.05$

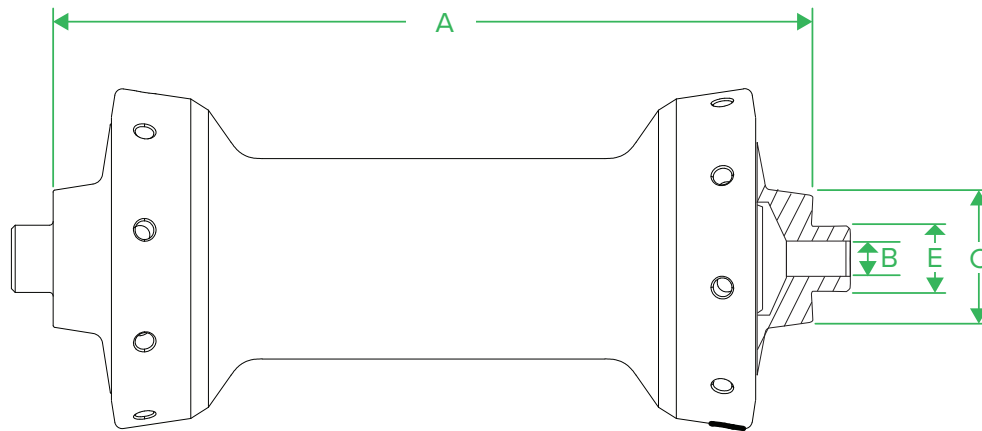

# Zipp Rim Brake Hubs

## Rear Hub Specifications

10x130 Quick Release Hub	A (mm)	B (mm)	C (mm)	E (mm)	F (mm)
	$130.7 \pm 0.3/-1.0$	$\text{Ø } 5.3 \pm 0.1$	$\text{Ø } 19.5 \pm 0.1$	$\text{Ø } 9.85 \pm 0.05$	$42.4 \pm 0.2$

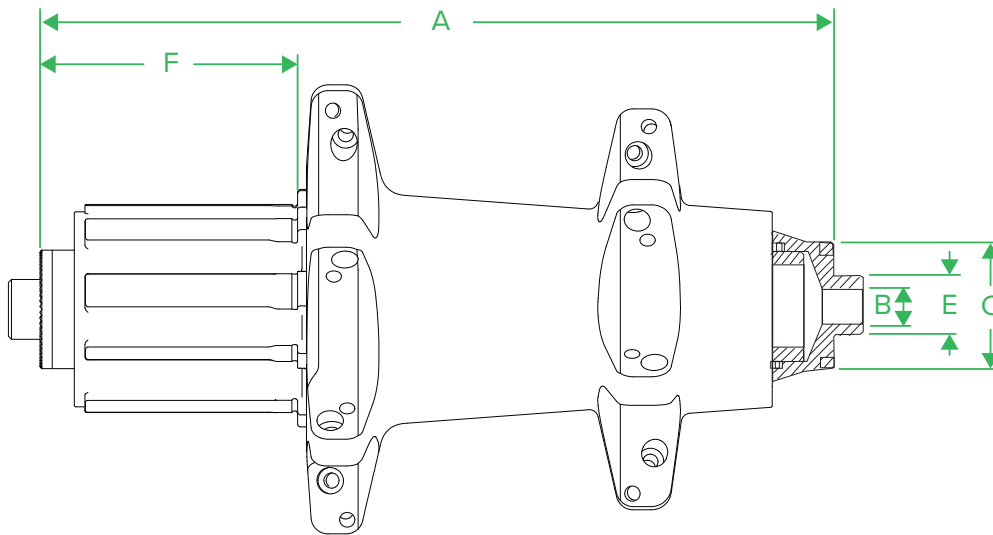

# Maxle Description Decoder

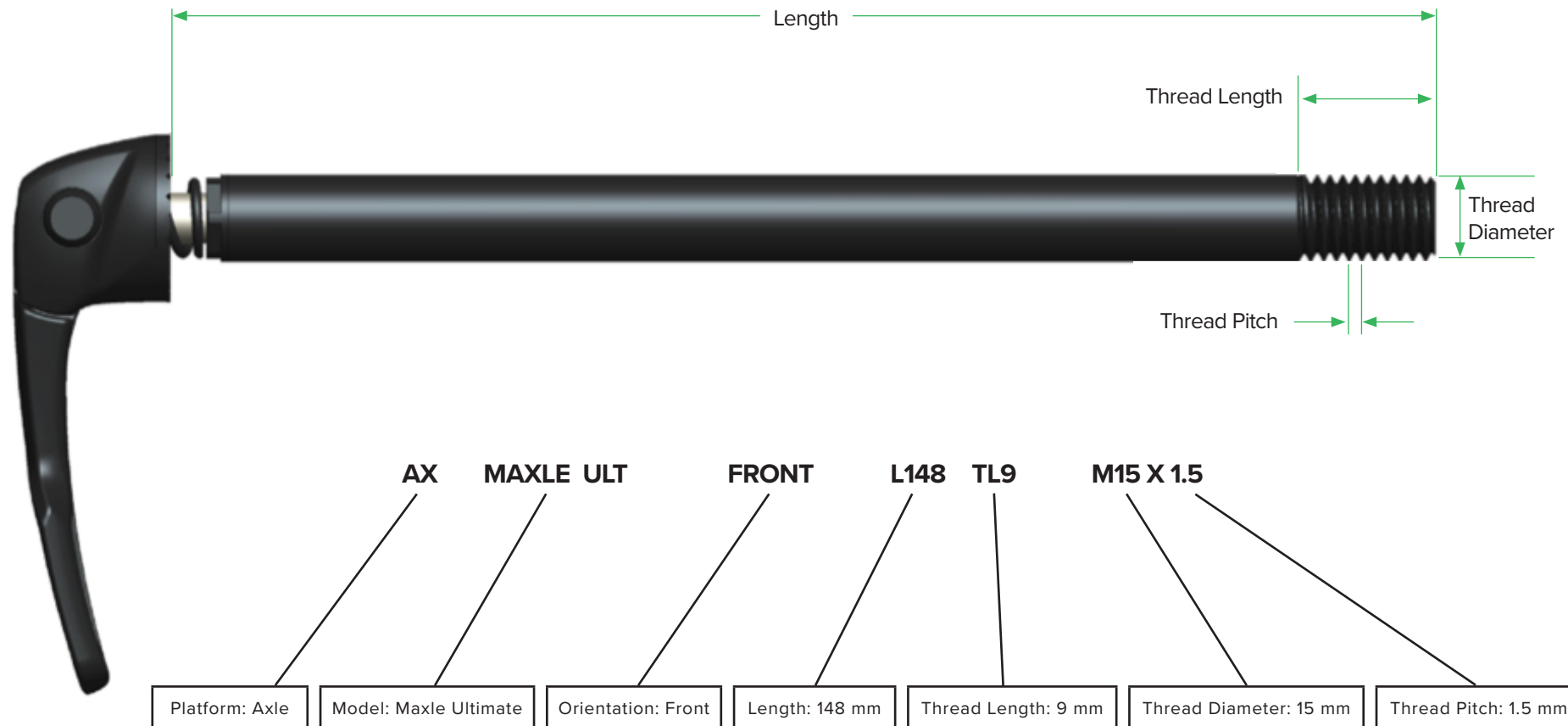

# Maxle Ultimate

## Frame / Fork Clearance

Lever in Closed Position

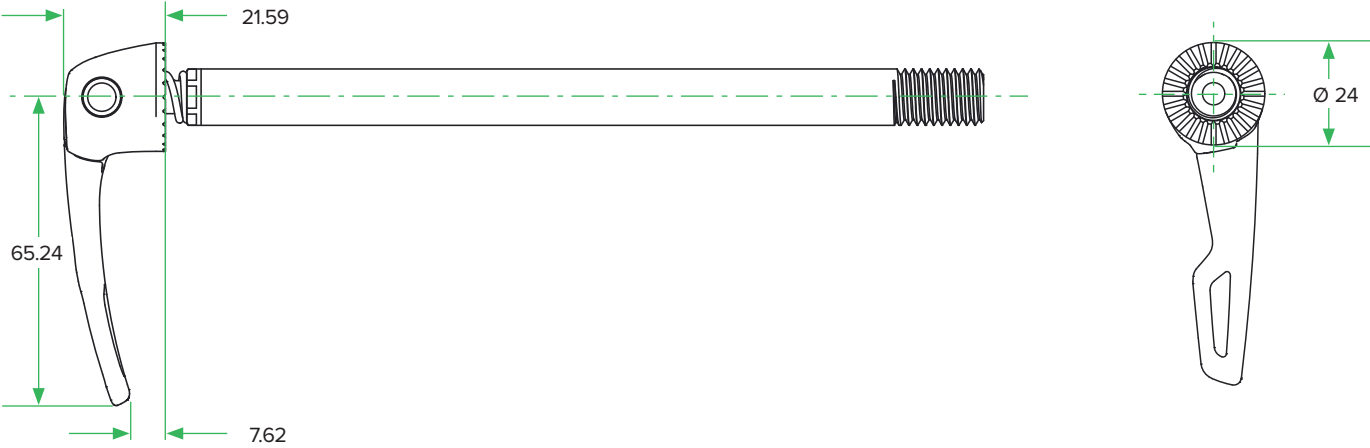

Lever in Open Position

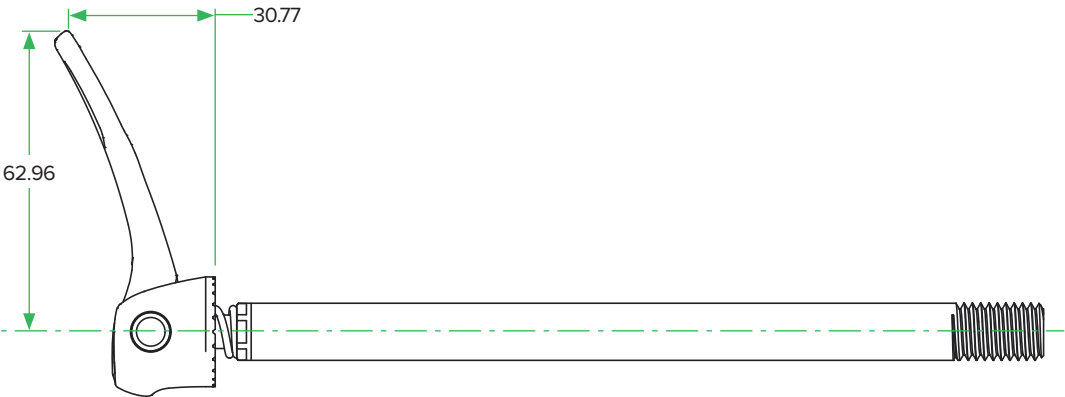

- 1 Drawing is not to scale.
- 2 Customer is responsible for ensuring hub, frame, and axle compatibility.
- 3 The frame manufacturer is responsible for ensuring the frame and/or fork assemblies using Maxles are compliant with existing safety standards.
- 4 Head translates along the Maxle axis approximately 1.46 mm when lever is moved from open to closed.

# Maxle Stealth

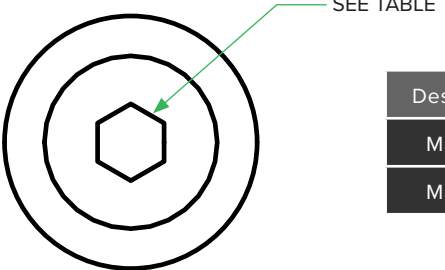
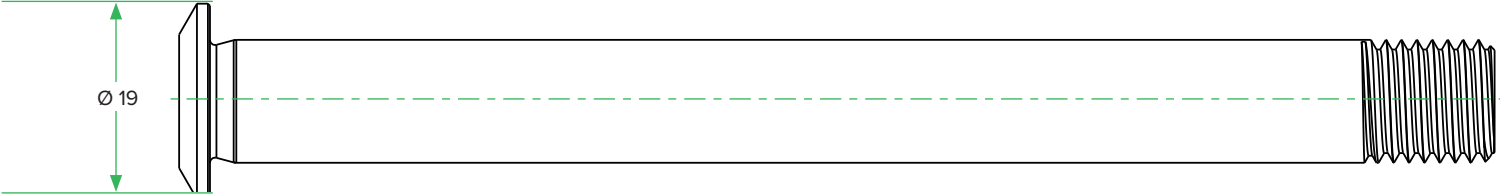

Description	Hex Size	Torque Value
Maxle 12	5	9-13.5 N·m
Maxle 15	6	9-13.5 N·m

- 1 Drawing is not to scale.
- 2 Customer is responsible for ensuring hub, frame, and axle compatibility.
- 3 The frame manufacturer is responsible for ensuring the frame and/or fork assemblies using Maxles are compliant with existing safety standards.

# Maxle Lite & Maxle

## Frame / Fork Clearance

Lever in Closed Position

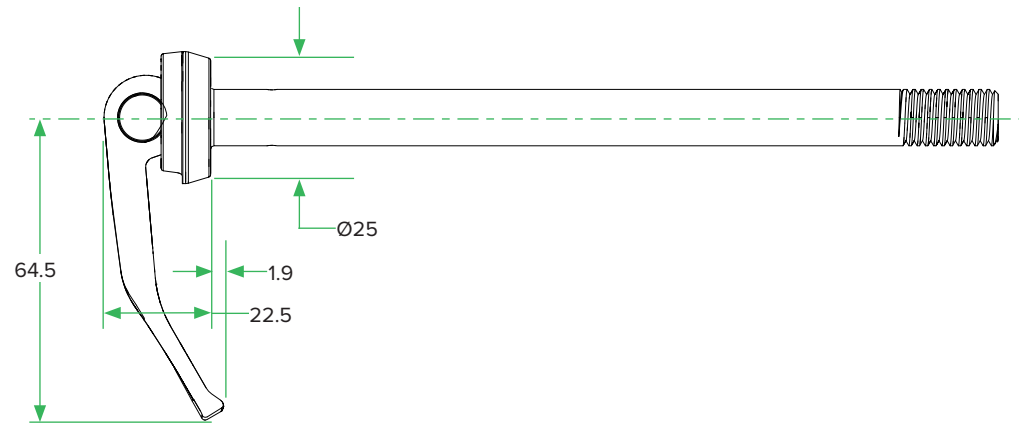

Lever in Open Position

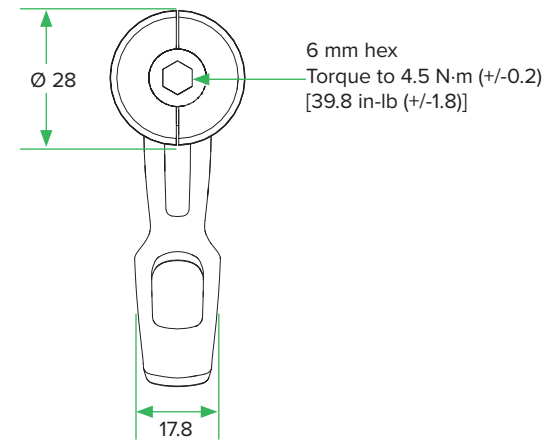

- 1 Drawing is not to scale.
- 2 Customer is responsible for ensuring hub, frame, and axle compatibility.
- 3 The frame manufacturer is responsible for ensuring the frame and/or fork assemblies using Maxles are compliant with existing safety standards.



# Maxle, Maxle Lite, Maxle Ultimate, Maxle Stealth

## Rear Frame Specification

Frame Dropouts with Axle Installed

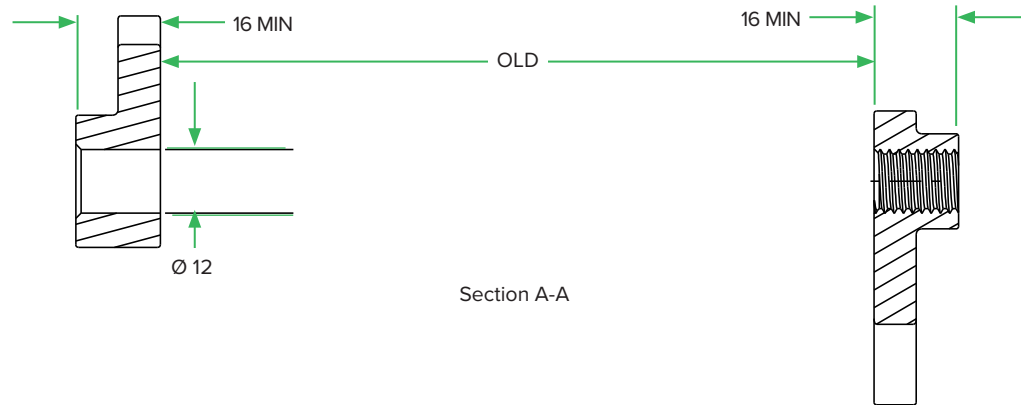
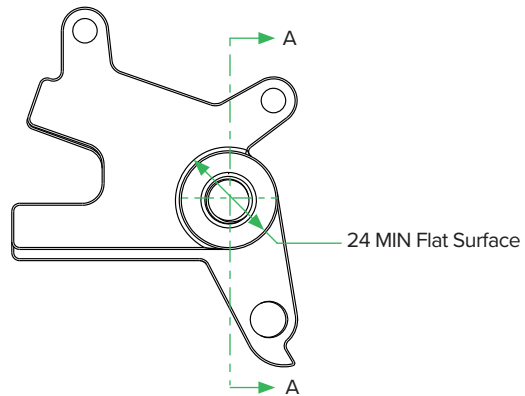
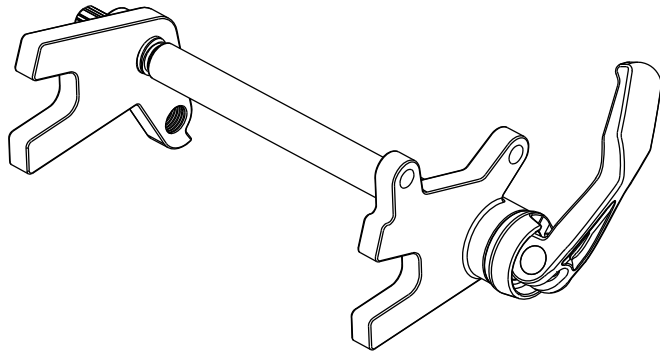

# Maxle, Maxle Lite, Maxle Ultimate, Maxle Stealth

## Fork Specification

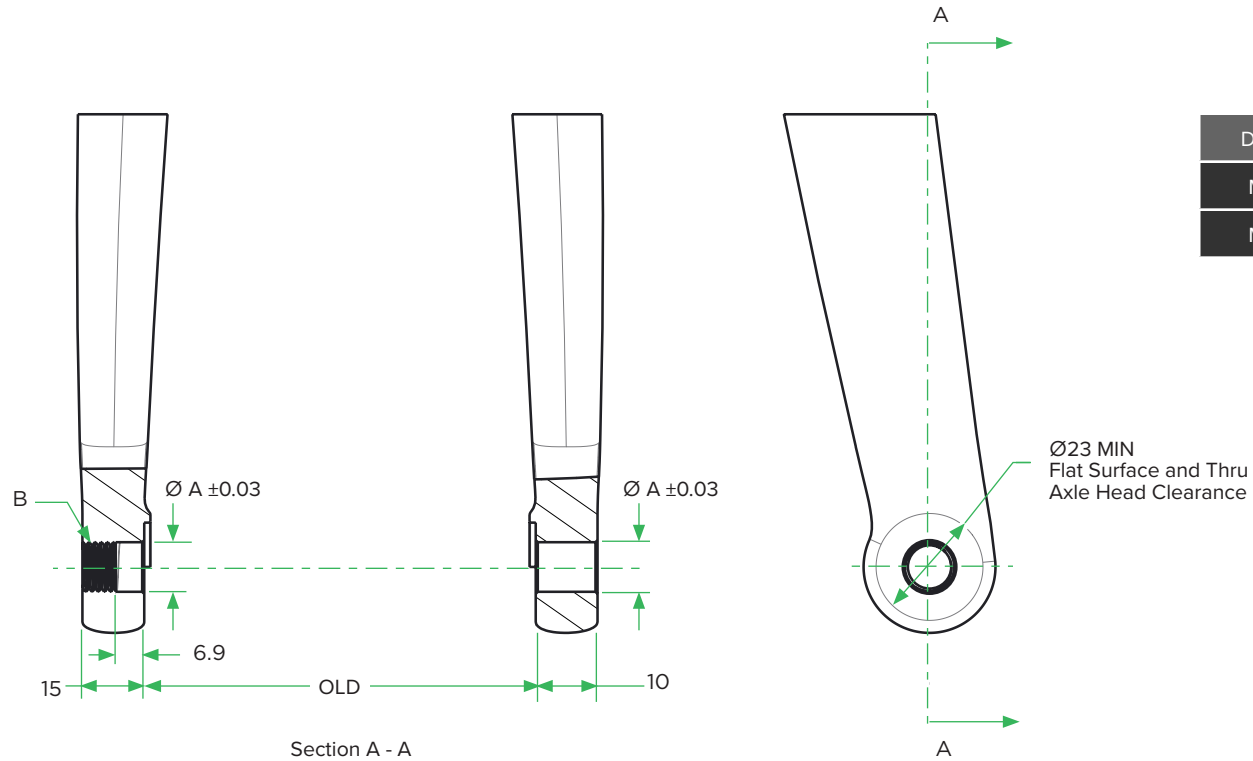

Description	A	B
MAXLE 15	14.98	M15 X 1.5 - 6H
MAXLE 12	12.03	M12 X 1.5 - 6H

# Maxle, Maxle Lite, Maxle Ultimate, Maxle Stealth

## Fork Specification

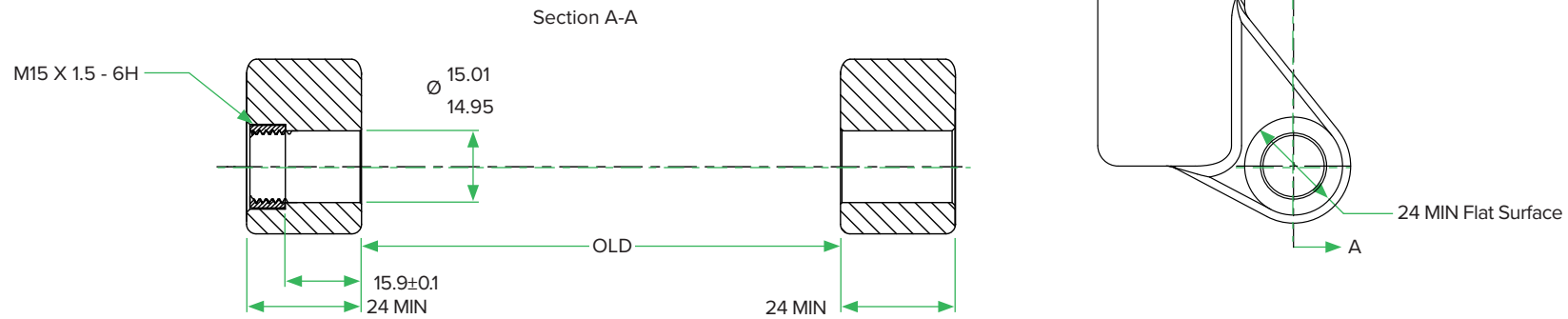

**These are registered trademarks of SRAM, LLC:**

1:1®, Accuwatt®, Avid®, Bar®, Blackbox®, BoXXer®, DoubleTap®, Elita®, eTap®, Firecrest®, Firex®, Grip Shift®, GXP®, Hammerschmidt®, Holzfeller®, Hussefelt®, i-Motion®, Judy®, Know Your Powers®, NSW®, Omnium®, Pike®, PowerLock®, Quarq®, Qollector®, RacerMate®, Reba®, Rock Shox®, Ruktion®, Service Course®, ShockWiz®, SID®, Single Digit®, Speed Dial®, Speed Weaponry®, Spinscan®, SRAM®, SRAM APEX®, SRAM EAGLE®, SRAM FORCE®, SRAM RED®, SRAM RIVAL®, SRAM VIA®, Stylo®, Torpedo®, The Power of Bicycles®, Truvativ®, Varicrank®, Velotron®, World Bicycle Relief®, X0®, X01®, X-SYNC®, XX1®, Zed tech®, ZIPP®

**These are registered logos of SRAM, LLC:**



**These are trademarks of SRAM, LLC:**

10K™, 1X™, 202™, 30™, 35™, 302™, 303™, 404™, 454™, 808™, 858™, 3ZERO MOTO™, ABLC™, AeroGlide™, AeroBalance™, AeroLink™, Airea™, Air Guides™, AKA™, AL-7050-TV™, Automatic Drive™, Automatik™, AxCad™, Axial Clutch™, AXS™, BB5™, BB7™, BB30™, Bleeding Edge™, Blipbox™, BlipClamp™, BlipGrip™, Blips™, Bluto™, Bottomless Tokens™, Cage Lock™, Carbon Bridge™, Centera™, Charger 2™, Charger™, Clickbox Technology™, Clics™, Code™, Cognition™, Connectamajig™, Counter Measure™, DD3™, DD3 Pulse™, DebonAir™, Deluxe™, Deluxe Re:Aktiv™, Descendant™, DFour™, DFour91™, Dig Valve™, DirectLink™, Direct Route™, DOT 5.1™, Double Decker™, Double Time™, Dual Flow Adjust™, Dual Position Air™, DUB™, DZero™, E300™, E400™, Eagle™, E-Connect4™, E-matic™, ErgoBlade™, ErgoDynamics™, ESP™, EX1™, Exact Actuation™, Exogram™, Flow Link™, FR-5™, Full Pin™, Gnar Dog™, Guide™, GX™, Hard Chrome™, Hexfin™, HollowPin™, Howitzer™, HRD™, Hybrid Drive™, Hyperfoil™, i-3™, Impress™, Jaws™, Jet™, Kage™, Komfy™, Level™, Lyrik™, MatchMaker™, Maxle™, Maxle 360™, Maxle DH™, Maxle Lite™, Maxle Lite DH™, Maxle Stealth™, Maxle Ultimate™, Micro Gear System™, Mini Block™, Mini Cluster™, Monarch™, Monarch Plus™, Motion Control™, Motion Control DNA™, MRX™, Noir™, NX™, OCT™, OmniCal™, OneLoc™, Paragon™, PC-1031™, PC-1110™, PC-1170™, PG-1130™, PG-1050™, PG-1170™, Piggyback™, Poploc™, Power Balance™, Power Bulge™, PowerChain™, PowerDomeX™, Powered by SRAM™, PowerGlide™, PowerLink™, Power Pack™, Power Spline™, Predictive Steering™, Pressfit™, Pressfit 30™, Prime™, Qalvin™, R2C™, RAIL™, Rapid Recovery™, Re:Aktiv ThruShaft™, Recon™, Reverb™, Revelation™, Riken™, Rise™, ROAM™, Roller Bearing Clutch™, RS-1™, Sag Gradients™, Sawtooth™, SCT - Smart Coasterbrake Technology, Seeker™, Sektor™, SHIFT™, ShiftGuide™, Shorty™, Showstopper™, Side Swap™, Signal Gear Technology™, SL™, SL-70™, SL-70 Aero™, SL-70 Ergo™, SL-80™, SL-88™, SLC2™, SL SPEED™, SL Sprint™, Smart Connect™, Solo Air™, Solo Spoke™, SpeedBall™, Speed Metal™, SRAM APEX 1™, SRAM Force 1™, SRAM RIVAL 1™, S-series™, Stealth-a-majig™, StealthRing™, Super-9™, Supercork™, Super Deluxe™, Super Deluxe Coil™, SwingLink™, SX™, SX Eagle™, TaperCore™, Timing Port Closure™, Tool-free Reach Adjust™, Top Loading Pads™, Torque Caps™, TRX™, Turnkey™, TwistLoc™, Tyrewiz™, VCLC™, Vivid™, Vivid Air™, Vuka Aero™, Vuka Alumina™, VukaBull™, Vuka Clip™, Vuka Fit™, Wide Angle™, WiFLi™, X1™, X5™, X7™, X9™, X-Actuation™, XC™, X-Dome™, XD™, XD Driver Body™, XDR™, XG-1150™, XG-1175™, XG-1180™, XG-1190™, X-Glide™, X-GlideR™, X-Horizon™, XLoc Sprint™, XX™, Yari™, Zero Loss™



Specifications and colors subject to change without prior notice.

© 2019 SRAM, LLC

---

ASIAN HEADQUARTERS

SRAM Taiwan  
No. 1598-8 Chung Shan Road  
Shen Kang Hsiang, Taichung City  
Taiwan R.O.C.

WORLD HEADQUARTERS

SRAM LLC  
1000 W. Fulton Market, 4th Floor  
Chicago, Illinois 60607  
U.S.A.

EUROPEAN HEADQUARTERS

SRAM Europe  
Paasbosweg 14-16  
3862ZS Nijkerk  
The Netherlands