

BMC

ICS COMPATIBILITY

“01” Road and Gravel frameset introduced from 2016 are designed for ICS technology.

- Current ICS frames are fully compatible with any ICS cockpit and stem.
- Legacy ICS frames are fully compatible with 1st Generation ICS components.
- Legacy ICS frames compatibility with 2nd generation ICS components is limited

- The installation of ICS cockpits and stems requires the use of the correct topcone and spacer kit.
- Retrofit kits include both topcones heights and spacers.

Topcones
(Positioned between frame and spacers)

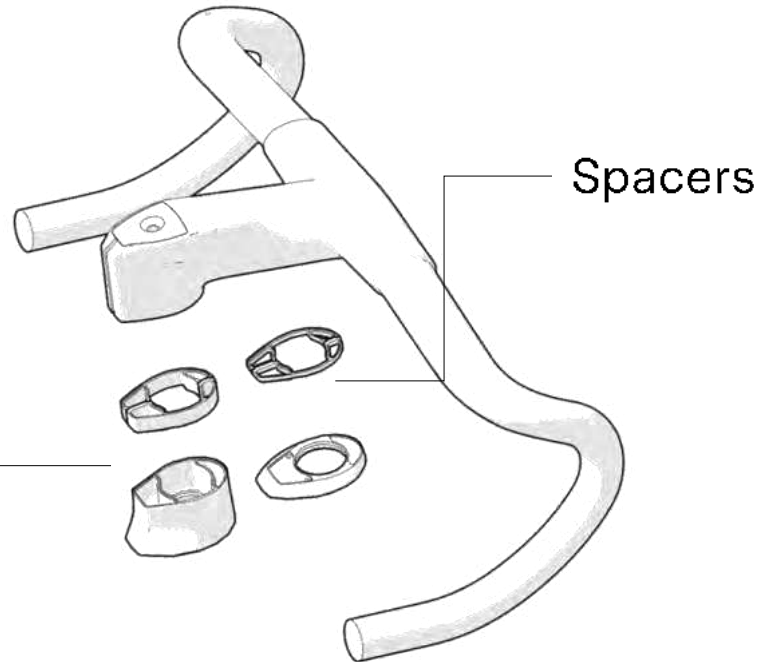

Current ICS Frames	Legacy ICS Frames
TEAMMACHINE SLR01 From 2021	TEAMMACHINE SLR01 From 2018
TIMEMACHINE ROAD 01 From 2019	ROADMACHINE 01 From 2017
ROADMACHINE 01 From 2020	ALPENCHALLENGE AMP CARBON From 2019
URS 01 From 2020	

1st and 2nd Generation ICS Compatible

1st Generation ICS Compatible

1st Generation and 2nd generation ICS components use different spacer and topcone interfaces.

2nd generation ICS components

- interlocking interface



- ✓ ICS Carbon
- ✓ ICS Carbon Aero
- ✓ ICS2 Stem
- ✓ ICS MTT Suspension Stem

1st generation ICS components

- “pin” interface

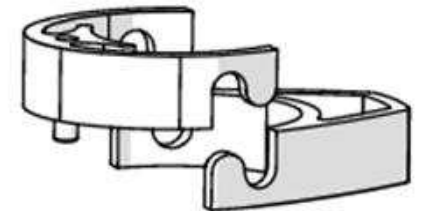

- ✓ ICS Aero Cockpit
- ✓ ICS01 Stem
- ✓ ICS01 0° Stem

Current ICS Frames

The following tables lists the kits required (topcones and spacers) to retrofit 1st or 2nd generation ICS Technology components on current ICS frames.

2nd Generation ICS



Description	Content	Frame	Color	Article #		
Topcones and Spacers Set for 2 nd Generation ICS components: ✓ ICS Carbon ✓ ICS Carbon Aero ✓ ICS2 Stem ✓ ICS MTT Suspension Stem	Topcones: 1 x 5 mm 1 x 30 mm Spacers: 3 x 10 mm 2 x 3mm	<ul style="list-style-type: none"> • Teammachine SLR 01 • Kaius 01 	BLACK	30001801		
			RED	30001802		
			WHITE	30003256		
				<ul style="list-style-type: none"> • Roadmachine 01 • URS 01 	BLACK	30001804
					BLACK	30003732
				<ul style="list-style-type: none"> • Timemachine Road 01 	RED	30003734
			WHITE	30003733		

1st Generation ICS



Description	Content	Frame	Color	Article #
Topcones and Spacers Set for 1 st Generation ICS components: ✓ ICS Aero Cockpit ✓ ICS01 Stem ✓ ICS01 0° Stem	Topcones: 1 x 5 mm 1 x 30 mm Spacers: 3 x 10 mm	<ul style="list-style-type: none"> • Teammachine SLR 01 • Kaius 01 	Black	30001800
		<ul style="list-style-type: none"> • Roadmachine 01 • URS 01 	BLACK	30001803
		<ul style="list-style-type: none"> • Timemachine Road 01 	BLACK	30003735

Legacy ICS Frames

Teammachine SLR 01 Disc (2018-2020 models) and Alpenchallenge AMP Carbon (2019-2021 models) frames are compatible with 1st and 2nd generation ICS components.

Roadmachine 01 frames (2017-2019 models) are NOT compatible with 2nd generation ICS components.

Legacy ICS models (complete bikes and modules) were factory equipped with 1st Generation ICS stems.

The following tables lists the kits required (topcones and spacers) to retrofit 1st or 2nd generation ICS Technology components on legacy ICS frames.

2nd Generation

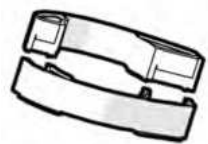

Description	Content	Frame	Color	Article #
Topcones and Spacers Set for 2 nd Generation ICS components: ✓ ICS Carbon ✓ ICS Carbon Aero ✓ ICS2 Stem ✓ ICS MTT Suspension Stem	Topcones: 1 x 5 mm 1 x 30 mm Spacers: 3 x 10 mm 2 x 3mm	Teammachine SLR 01 Disc • MY18/19/20 Alpenchallenge AMP Carbon • MY19/20/21	BLACK	30001804

1st Generation



Description	Content	Frame	Color	Article #
Topcones and Spacers Set for 1 st Generation ICS components: ✓ ICS Aero Cockpit ✓ ICS01 Stem ✓ ICS01 Ø ⁹ Stem	Topcones: 1 x 5 mm 1 x 30 mm Spacers: 3 x 10 mm	Teammachine SLR 01 Disc • MY18/19/20 Alpenchallenge AMP Carbon • MY19/20/21	BLACK	30001803

The first generation of Roadmachine 01 (MY17/18/19) is not compatible with 2nd Generation ICS components but can be retrofitted with 1st Generation ICS components without additional topcones or spacers.

1st Generation

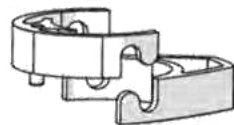

Description	Content	Frame	Color	Article #
Topcones for 1 st Generation ICS components: ✓ ICS Aero Cockpit ✓ ICS01 Stem ✓ ICS01 Ø ⁹ Stem	Topcones: 1 x 30 mm	Roadmachine 01 • MY17/18/19	BLACK	300712
	Topcones: 1 x 5 mm		BLACK	300713



Technical Manual

2nd Generation ICS One-Piece Cockpits and ICS Stems

- ICS Carbon
- ICS Carbon Aero
- ICS2 Stem
- ICS MTT Stem

STEM ASSEMBLY PREPARATION

A person's hands are shown assembling a red and black component on a wooden table. Various parts like a red ring, black rings, and a black pin are scattered on the table. The text "STEM ASSEMBLY PREPARATION" is overlaid in white.

Fork, headset and stem pre-tensioning

- Apply grease on the lower bearing seat on the frame, on the fork crown, then position the lower bearing on it
- Apply grease on the upper bearing seat on the frame and then position the upper bearing on it

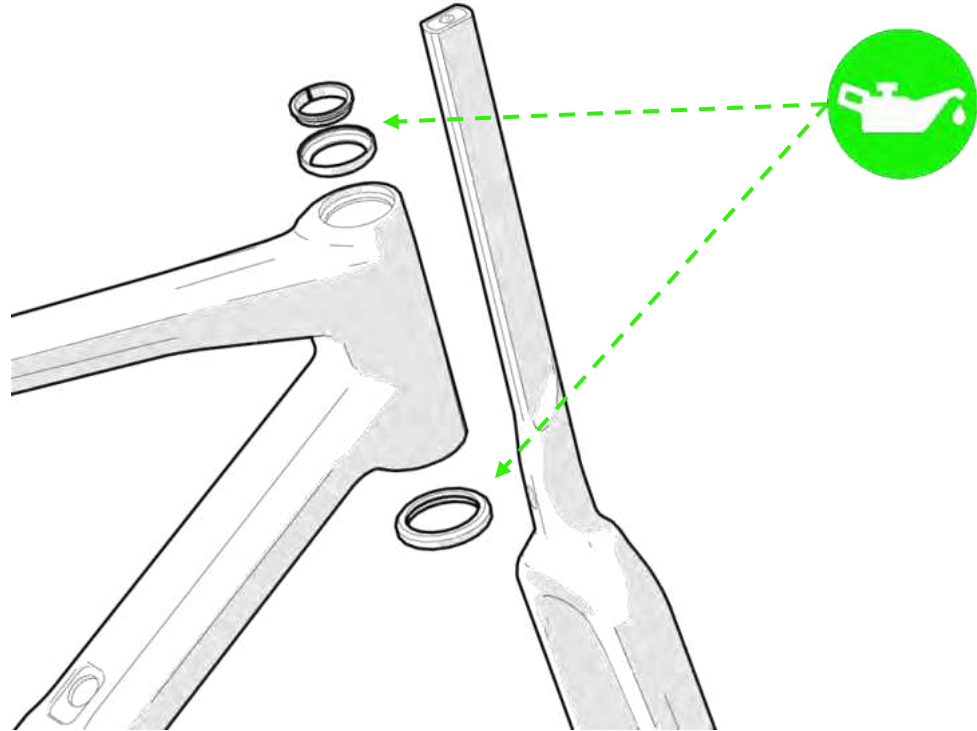

- Install the fork on the headtube
- Install the circlip on upper bearing
- Install the fork on the frame

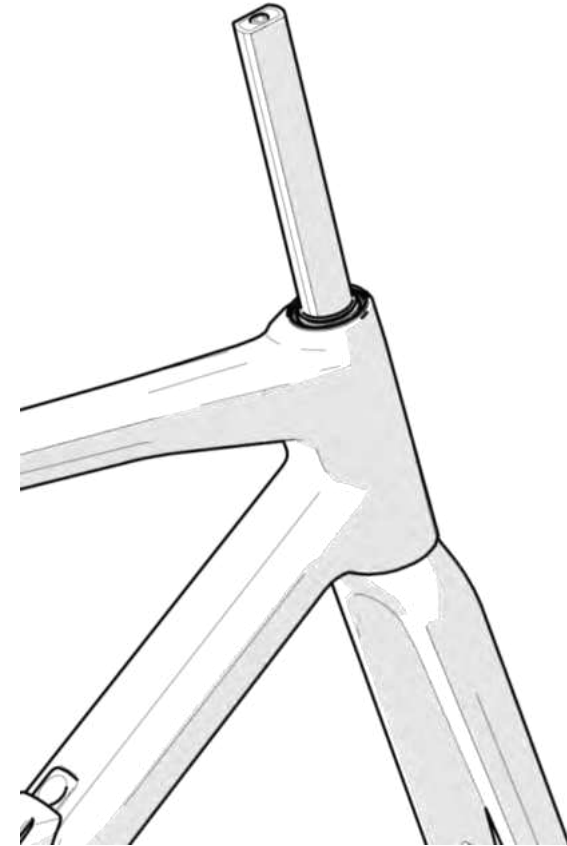

Topcone, Spacers and Stem/Cockpit configuration

Selected the desired topcone/ spacer configuration, choosing between:

- Low Topcone or High Topcone
- Spacers (10mm or 3mm)

1. Top Cone height
2. Spacers
3. Cockpit or Stem

Make sure you are using the correct spacers for 1st or 2nd generation cockpits

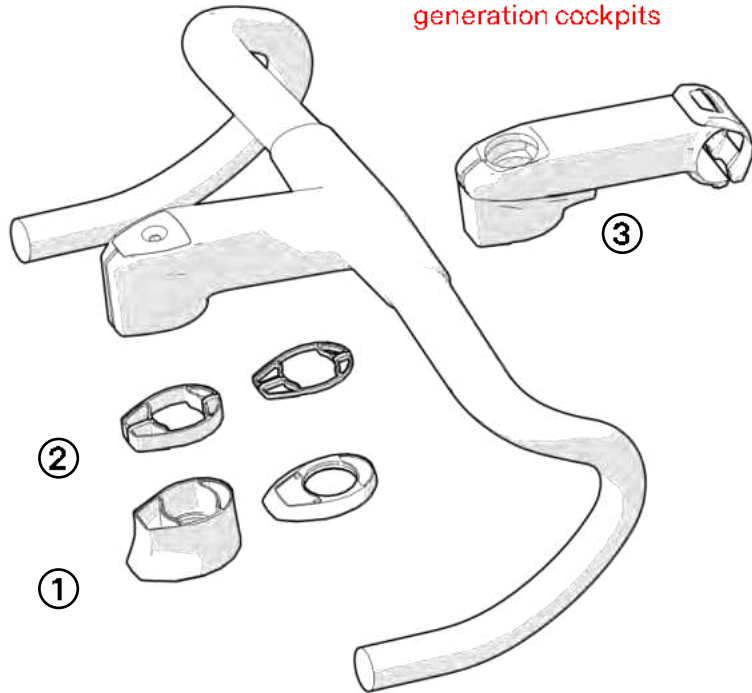

- Assemble the components on the frame.
- Make sure the spacers are aligned with the top cone
- The two halves of the spacers must well connect and engage with a click, see details below.

1st Generation

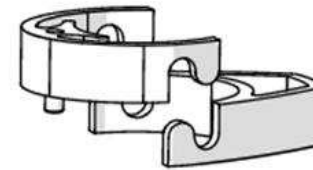

- The two halves of the spacers are not identical!

Ensure the concave face is facing up and the convex one is facing down

- Spacers are locked applying pressure

Spacers can be connected only when correctly oriented

2nd Generation

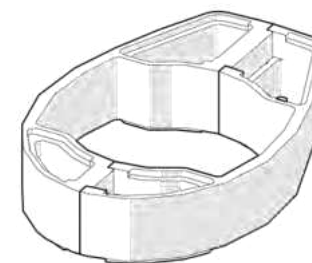

Top View concave face



Bottom View convex face

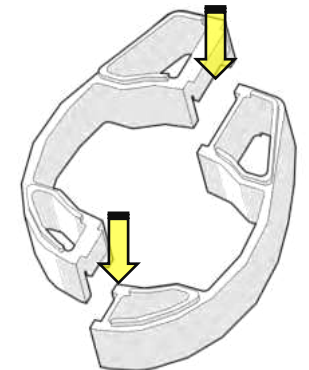

Topcap options (2nd Generation Only)

- The open top cap can be used on 2nd generation ICS components to add standard round spacers above the stem.
- This way it's possible to fine tune the riding position before cutting the steerer to its final lengths
- 1st Generation ICS Components only feature

- Consult the next pages to check the detailed assembly and ensure you are using the correct parts.
- All parts are included in the delivery of complete bikes, modules and stems/cockpits.

1. Flush Configuration
(Closed Top Cap)

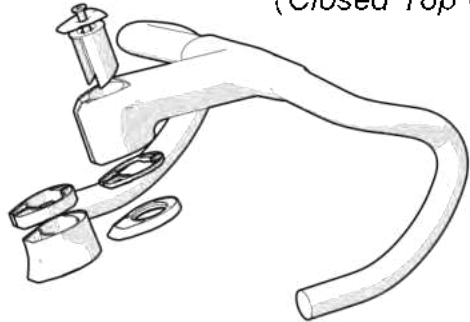

ICS Carbon

2. Open Configuration
(Open Top Cap)

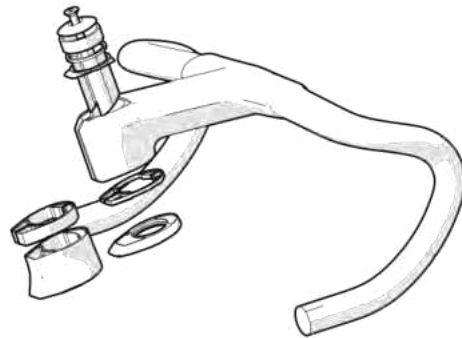

1. Flush Configuration
(Closed Top Cap)



ICS2

2. Open Configuration
(Open Top Cap)

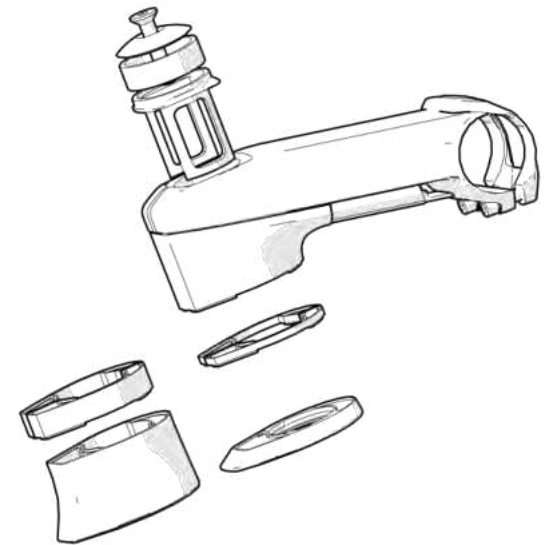

Closed Top Cap

1. Bolt
2. Flush Top Cap
3. Steerer Wedge

Open Top Cap

4. Compression Bolt
5. Round Top Cap
6. Standard Spacer
7. Lipped Steerer wedge for Round Spacers
8. Shaped Top Cap for Iround Spacers

ICS Carbon



Closed Top Cap

1. Compression Bolt
2. Flush Top Cap

Open Top Cap

3. Compression Bolt
4. Round Top Cap
5. Standard Spacer
6. Lipped Steerer wedge for Round Spacers

ICS2

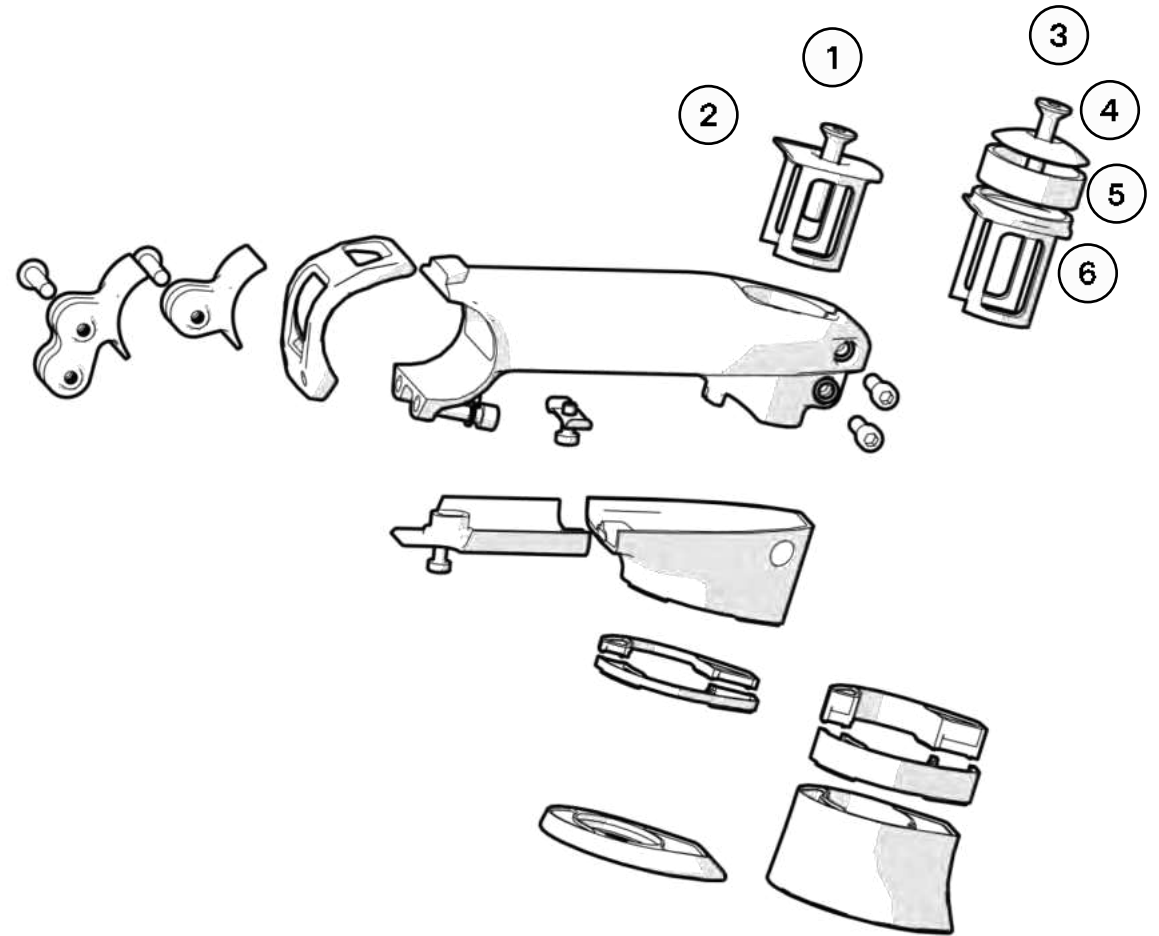

A close-up photograph of a person's hands using a hand saw to cut a metal rod. The rod is held in a red bench vise. The saw has a black handle and a silver blade. The person is wearing a white glove on their left hand. The background is a workshop setting with various tools and equipment.

STEERER CUTTING INSTRUCTIONS

(2nd Generation ICS Components)

- Compress the assembly by hand and make sure topcone, spacers and stem are well aligned.
- The procedure is identical for ICS2 and ICS Carbon, the illustration displays the procedure on the ICS Carbon cockpit

- For the Flush Configuration, mark the steerer where the top cap contacts the stem body.
- The example below shows where to mark the steerer to use the Flush Configuration for a clean look on ICS Carbon

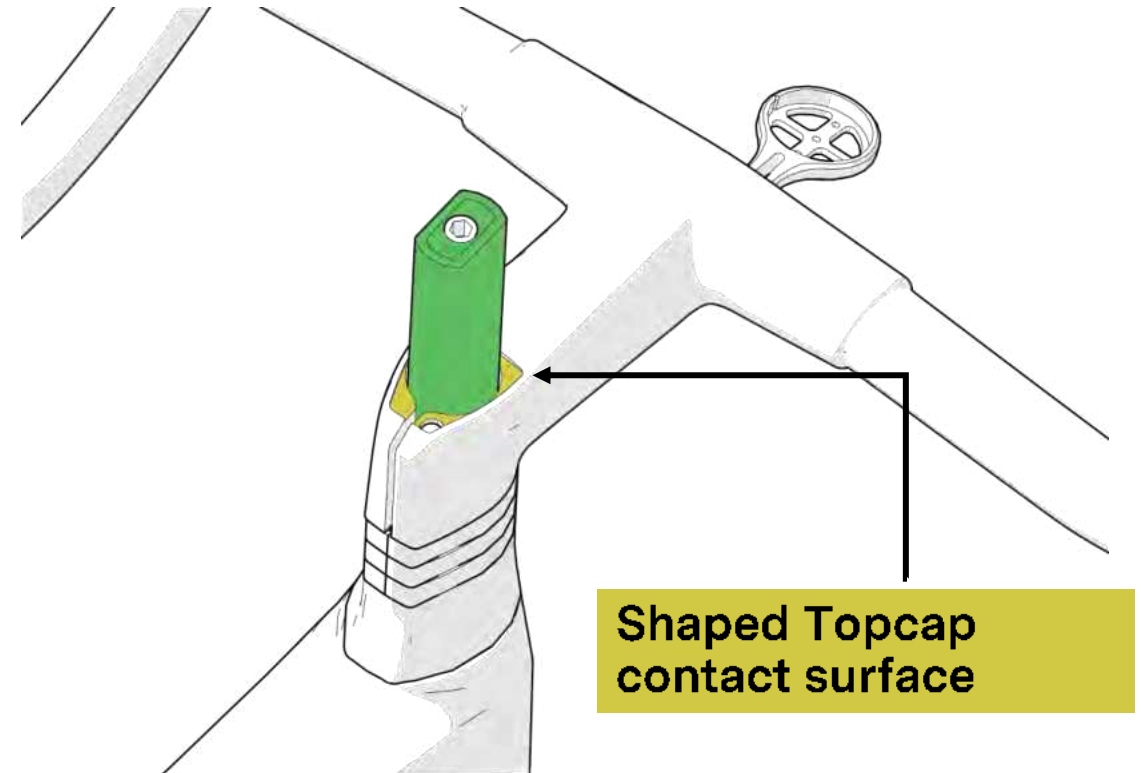
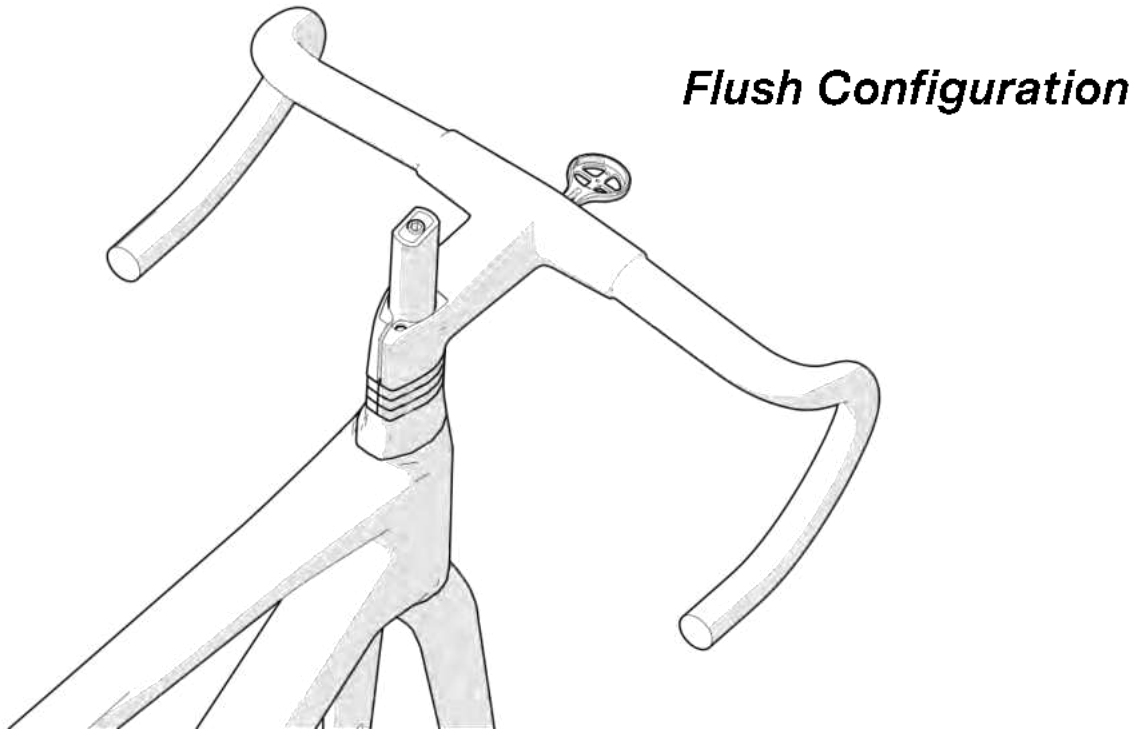

- For the Open Configuration, mark the steerer at the top of the last round spacer.
- The example below shows the where to mark the steerer when one spacer is being used above the stem.

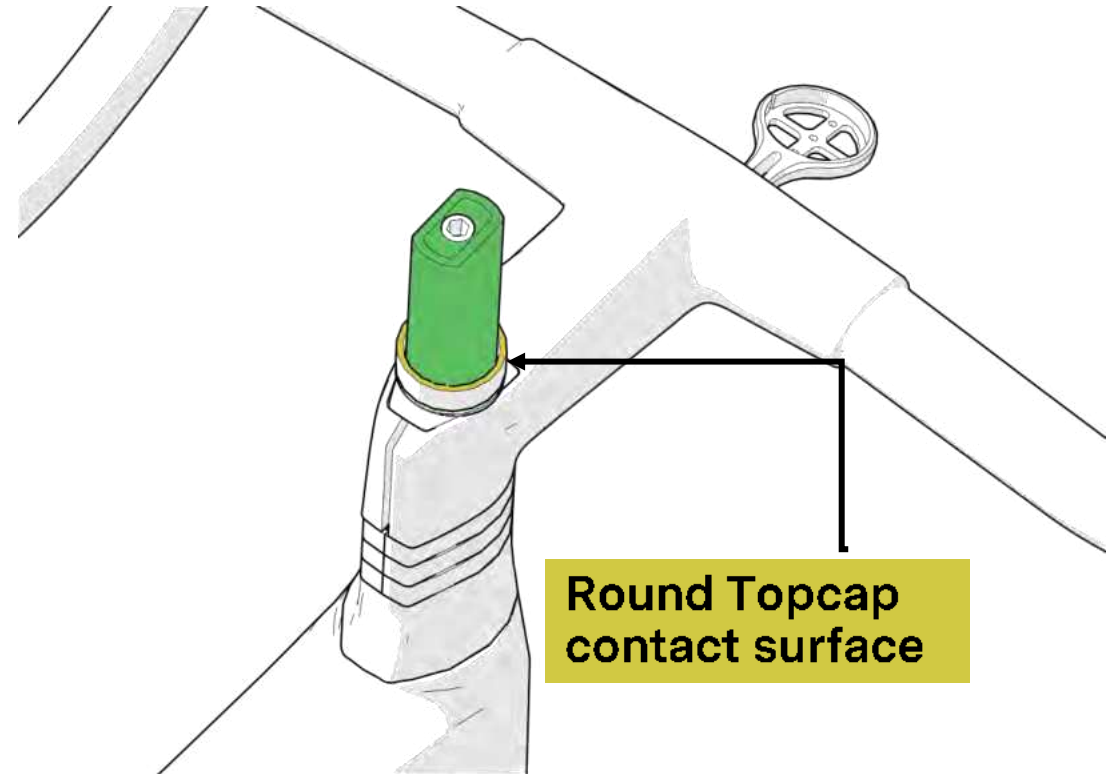
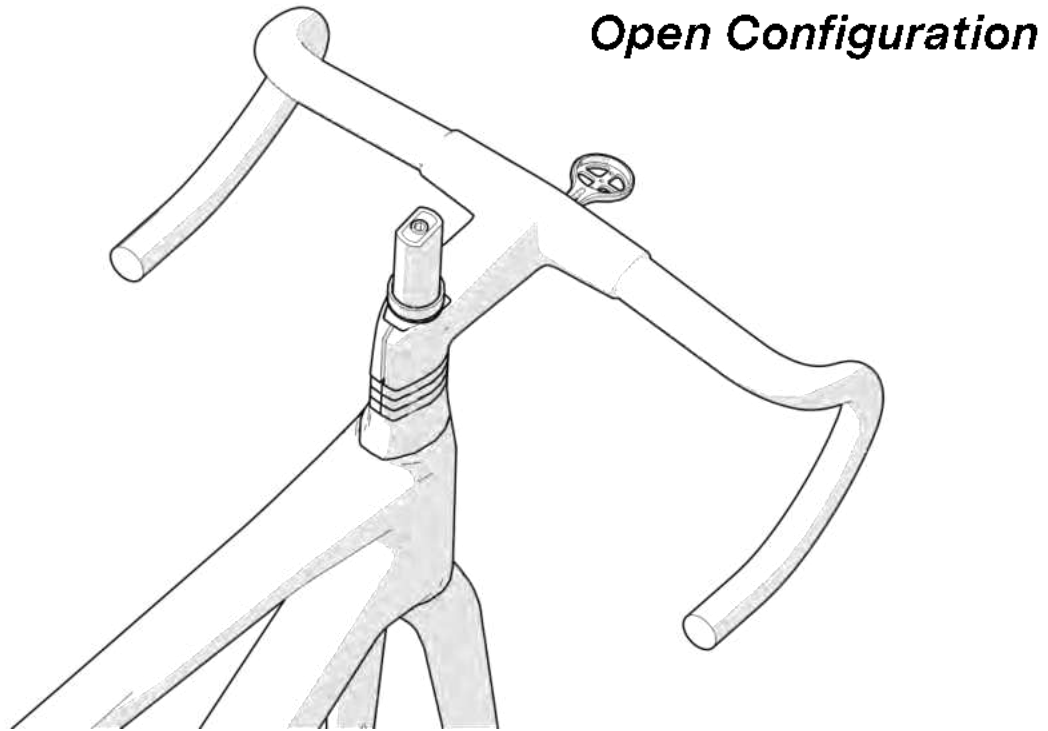

Fork steerer cutting mark

Once the height of the topcap contact point has been marked on the steerer (as of previous instructions) you can proceed to mark the steerer a second time.

The second mark is the final one and it will be used to cut the steerer.

Please note that the cutting mark is different from ICS2 to ICS Carbon.

- **ICS Carbon:** the steerer must be cut **4mm** below the topcap contact surface
- **ICS2:** the steerer must be cut **3mm** below the topcap contact surface of the stem.

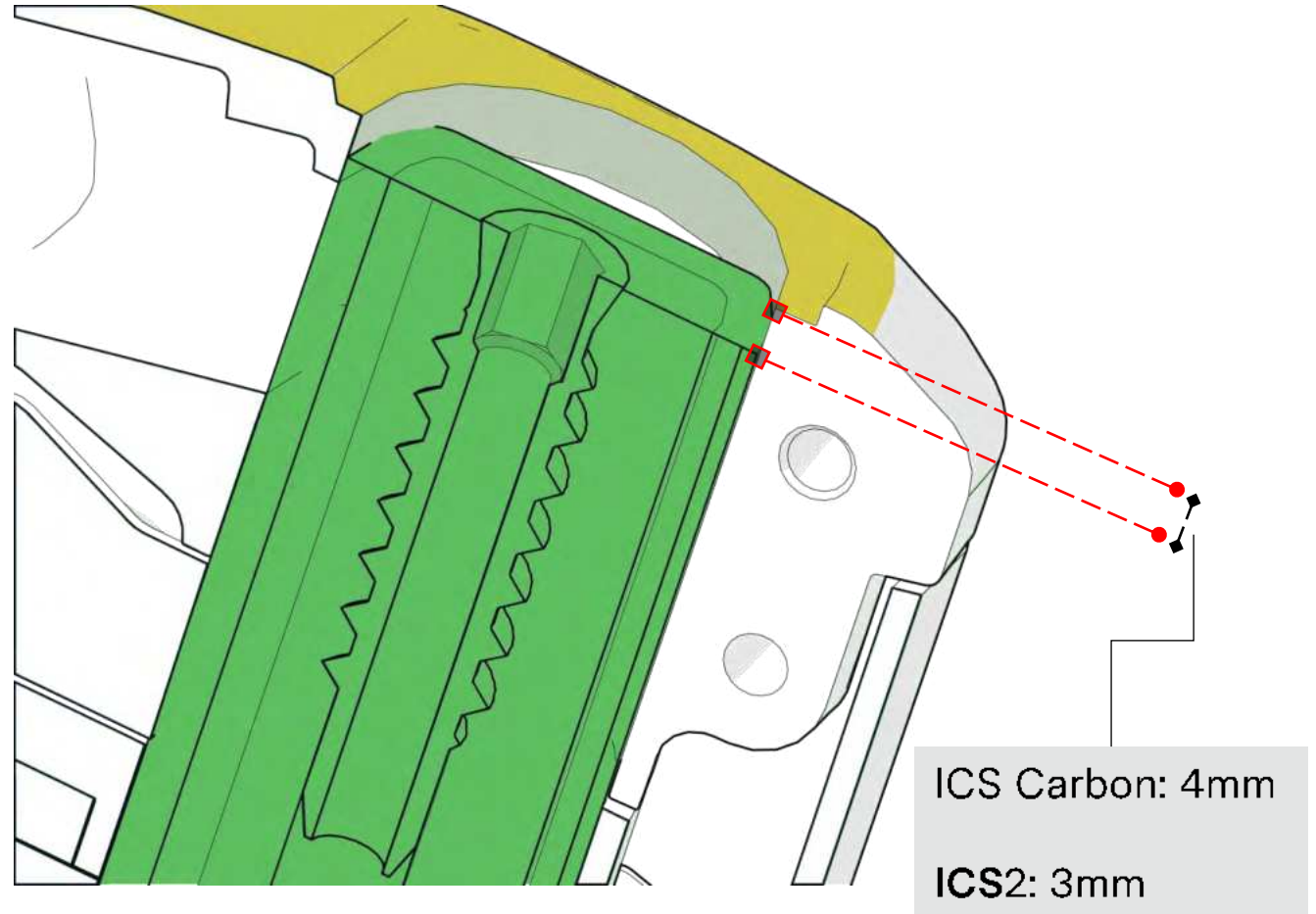

- Cut the steerer using a steerer cutting jig and a vice to ensure stability during cutting
- Deburr any sharp edge with fine grain sandpaper

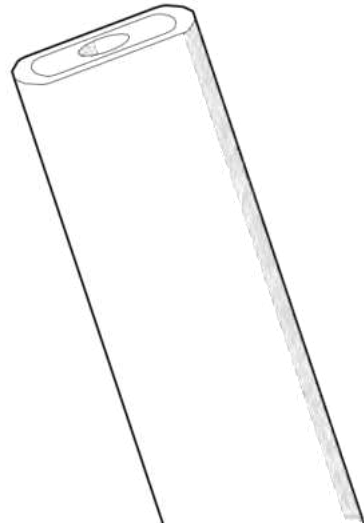

- After the steerer has been cut the self-cutting bolt can be threaded in until it is flush with surface.
- Remove any excess material produced during the installation of the bolt
- Grease the bolt for easier installation.

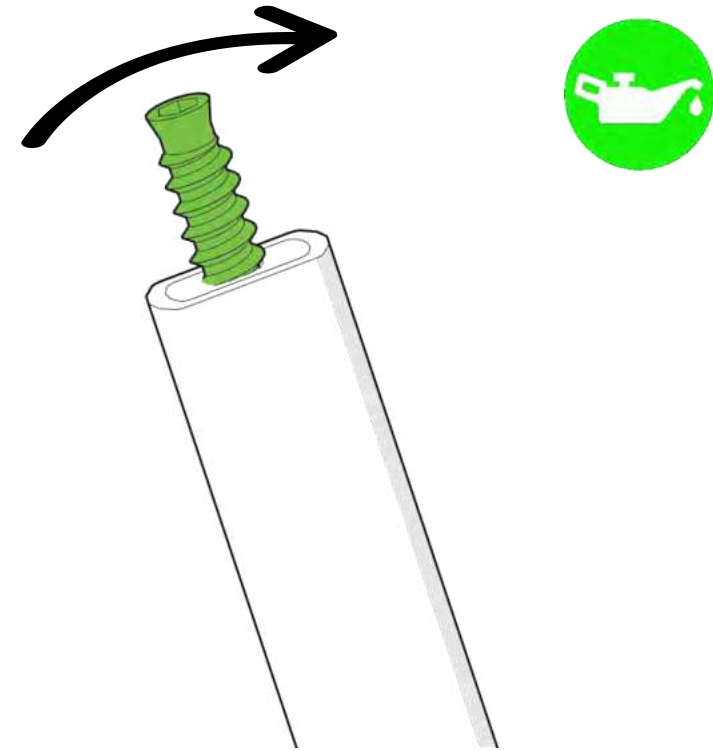

Function check:

- Install the fork, the headset, the stem and the topcap on the frame to check the headset functionality:
 - ✓ The headset has no play
 - ✓ The headset torque must be easily adjusted
 - ✓ The stem does not compress the fork steerer when tightened
- If the steerer has not been cut correctly (i.e., it's too long for the chosen configuration), the top cap might be interfering with the steerer, not allowing the headset to be compressed.
- Shorten the steerer accordingly

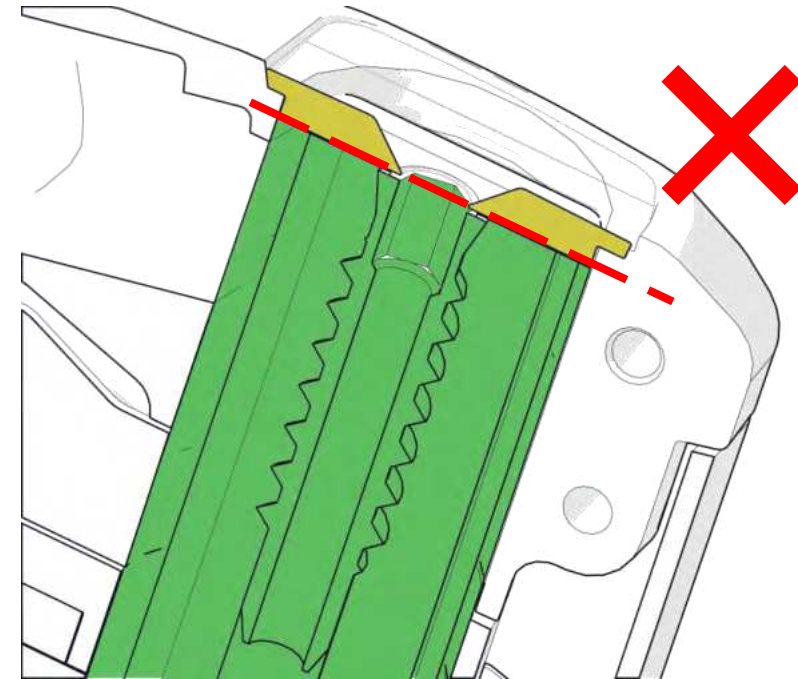
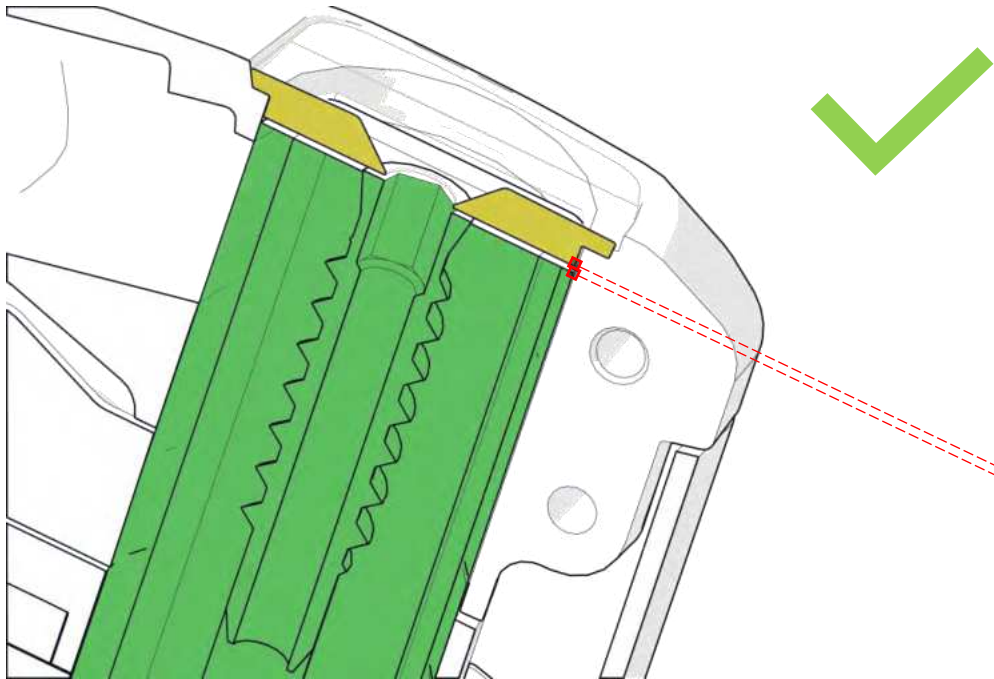

Ensure 1mm gap between the steerer and the topcap with the topcap installed!

A close-up photograph of a person's hands working on a bicycle's brake assembly. The person is wearing a dark grey t-shirt. They are holding a black metal brake arm with a silver-colored metal fitting. A thin, light-colored cable is being inserted into the fitting. The background is a workshop with a wooden workbench and various tools. The text "BRAKE ASSEMBLY" is overlaid in white, bold, sans-serif font across the center of the image.

BRAKE ASSEMBLY

- Guide brake hose into fork

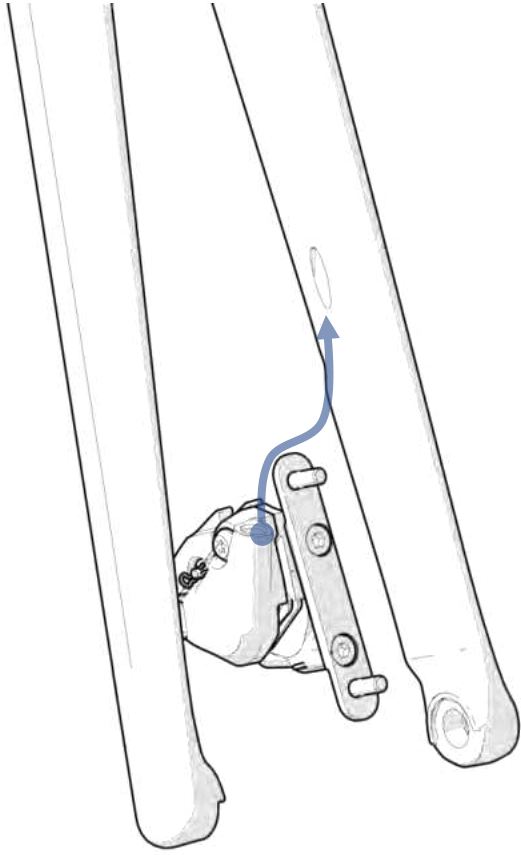

- Attach the front brake to the fork

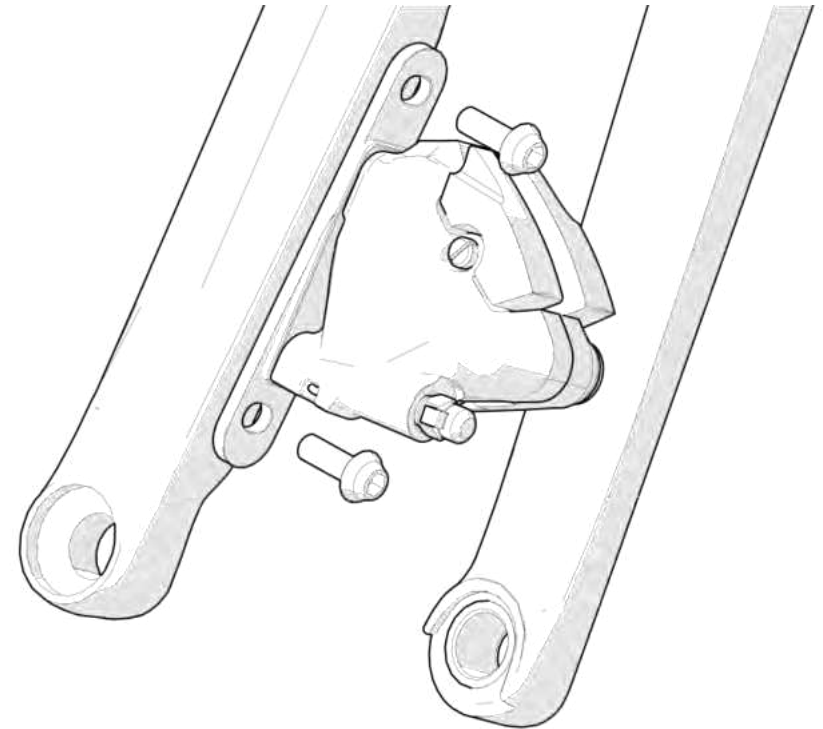

Standard style brake assembly for ICS2

The front brake hose runs on the left side of the steerer tube

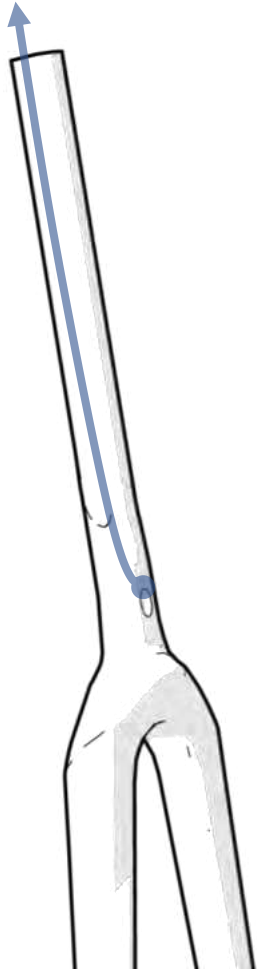

UK style brake assembly for ICS2 and standard brake assembly for ICS Carbon

For UK style brake assembly and for ICS Carbon the front brake hose runs on the right side of the steerer tube

This is due to the fact that the cables cross to opposite side inside the ICS Carbon cockpit.

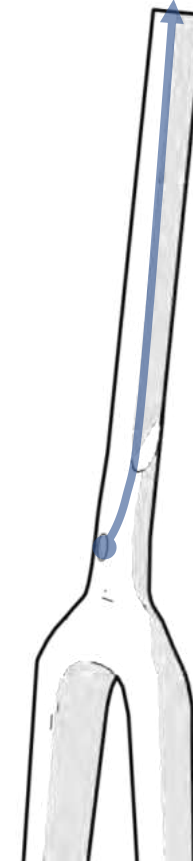

A close-up photograph of a person's hands holding a red-handled level against a black metal structure. The background is a blurred workshop or factory floor. The text is overlaid on the image.

FORK INSTALLATION AND CABLE ROUTING

2nd Generation ICS Cockpits

Fork installation

- Install the lower headset bearing on the fork and slide it into the frame
- Make sure the rear brake hose runs on the right side of the fork steerer tube for standard ICS2 assembly.
- It's recommended to use electric tape to prevent the brake hose from moving inside the head tube.

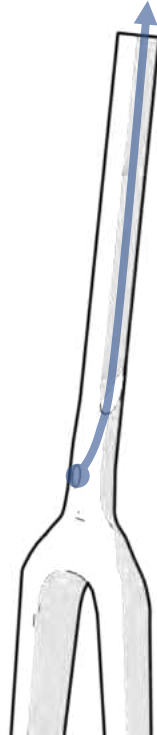

- For countries with inverted brakes (e.g., UK) and for ICS Carbon/Carbon Aero, the rear brake hose runs on the left side of the steerer tube. Check the diagram in the next page for details.

- Install upper headset bearing and cone
- The bearings need to be greased!

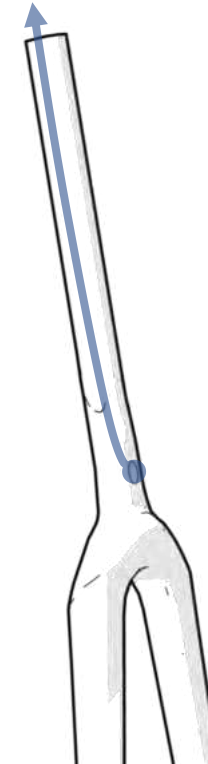

ICS Carbon / Carbon Aero Cockpits cable routing

ICS Carbon / Carbon Aero Standard Assembly

1. Rear Brake routing
2. Front Brake routing
3. Shimano Di2 cables

ICS Carbon / Carbon Aero Inverted Assembly (UK)

1. Front Brake routing
2. Rear Brake routing
3. Shimano Di2 cables

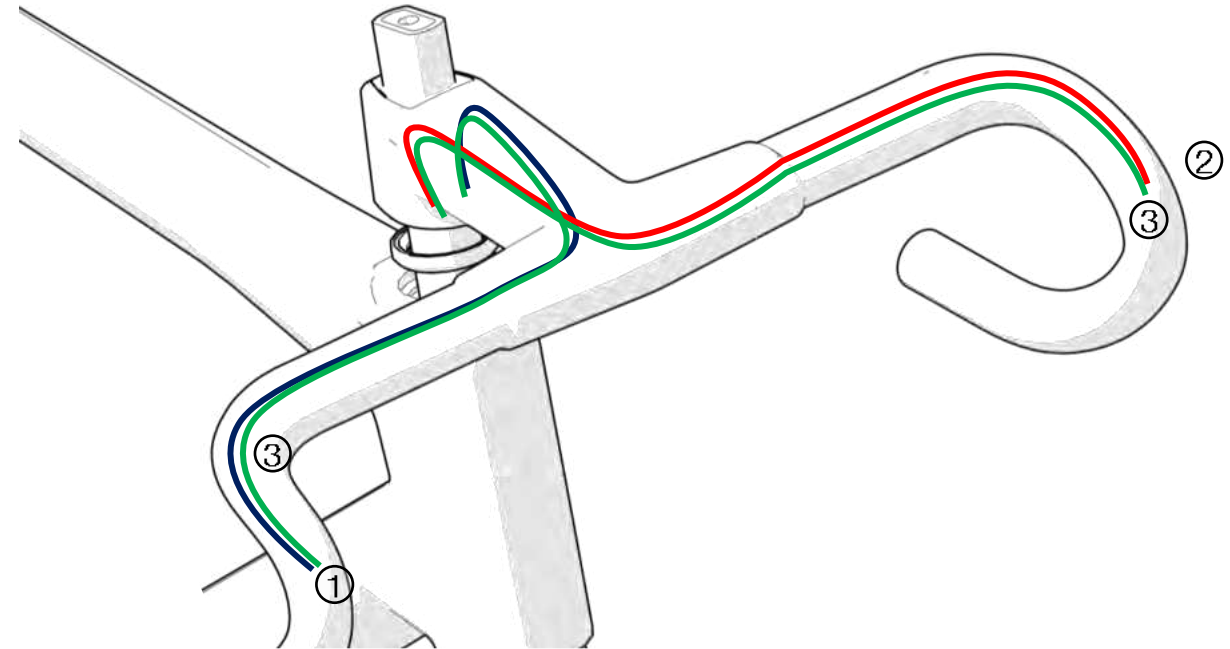
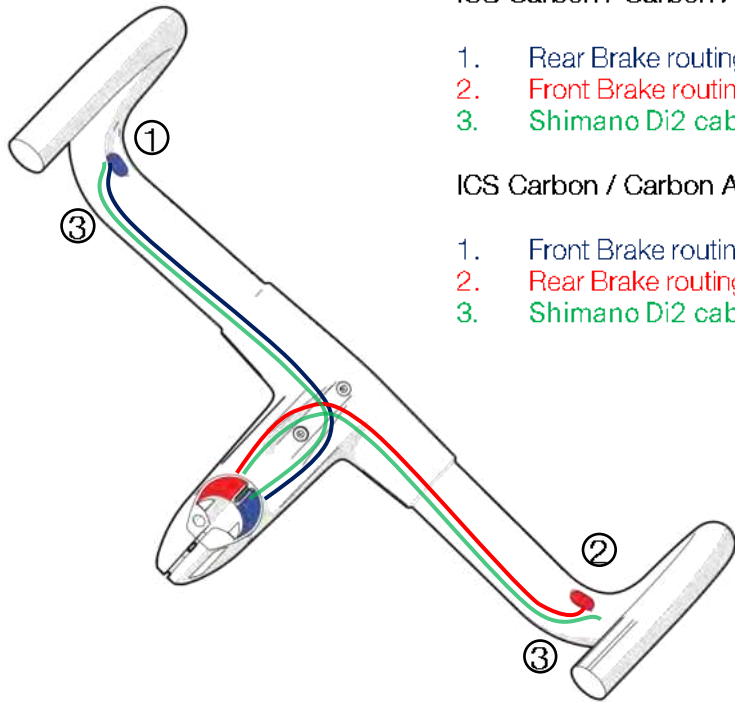

ICS Carbon / Carbon Aero Standard Assembly

1. Rear Brake routing
2. Front Brake routing
3. Shimano Di2 cables

ICS Carbon / Carbon Aero Inverted Assembly (UK)

1. Front Brake routing
2. Rear Brake routing
3. Shimano Di2 cables

ICS Stems cable routing

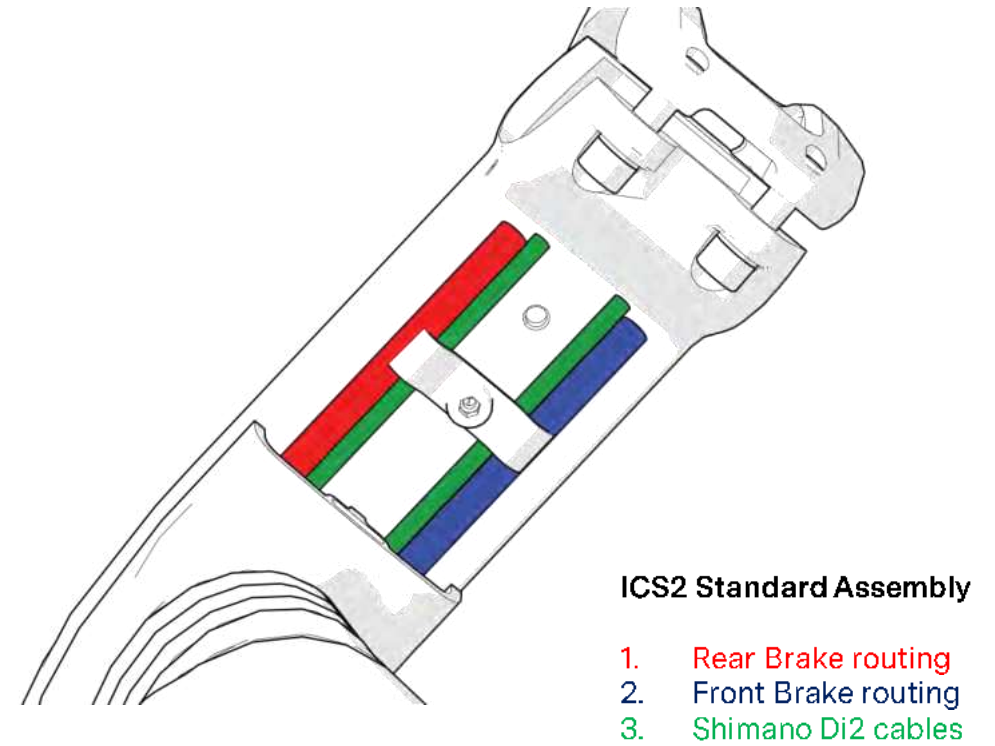
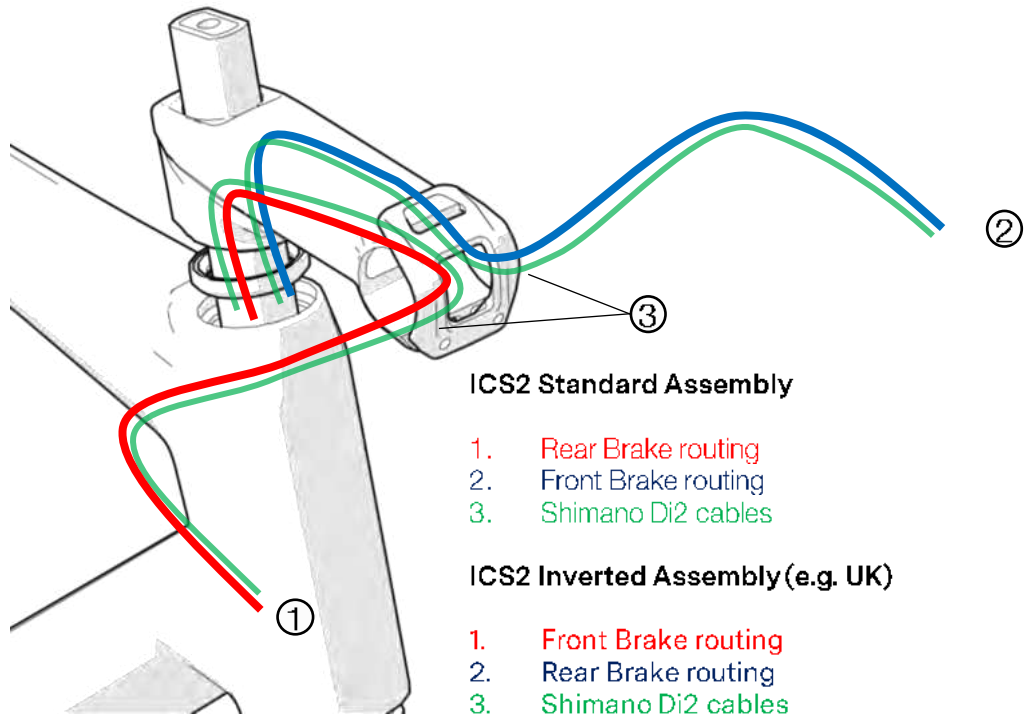



ICS Carbon Cockpits

ICS Carbon & ICS Carbon Aero Cockpit Installation

Prepare the top cap and spacer/top cone configuration based on which the steerer has been cut.

1. Select High or Low top cone
2. Select amount / height of Spacers

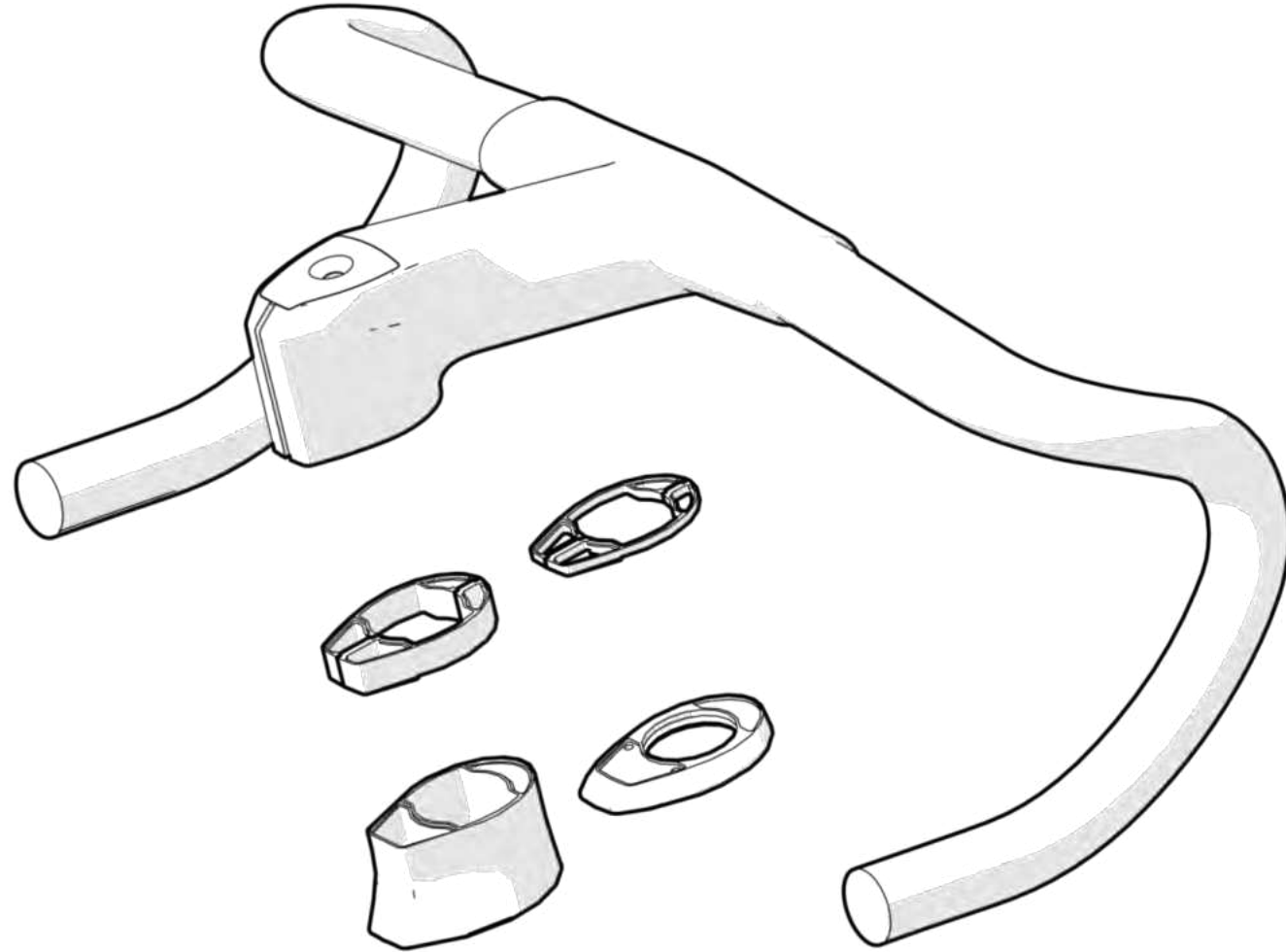

2nd generation ICS Cockpits and Stems feature shaped headset top caps for a cleaner look and can be setup in 2 different configurations.

1. The **flush configuration** provides a perfectly integrated look when the rider knows is ideal fit and decides to cut the fork steerer to a definitive length.
2. If the final fit has not yet been determined, the **open configuration** allows to easily adjust the cockpit height simply adjusting the interlocking spacer stack, the steerer does not have to be cut and **round spacers** can be used above the stem or cockpit to adjust the headset tension.

Important Note:

Make sure the steerer wedges are installed before the top caps on ICS Carbon

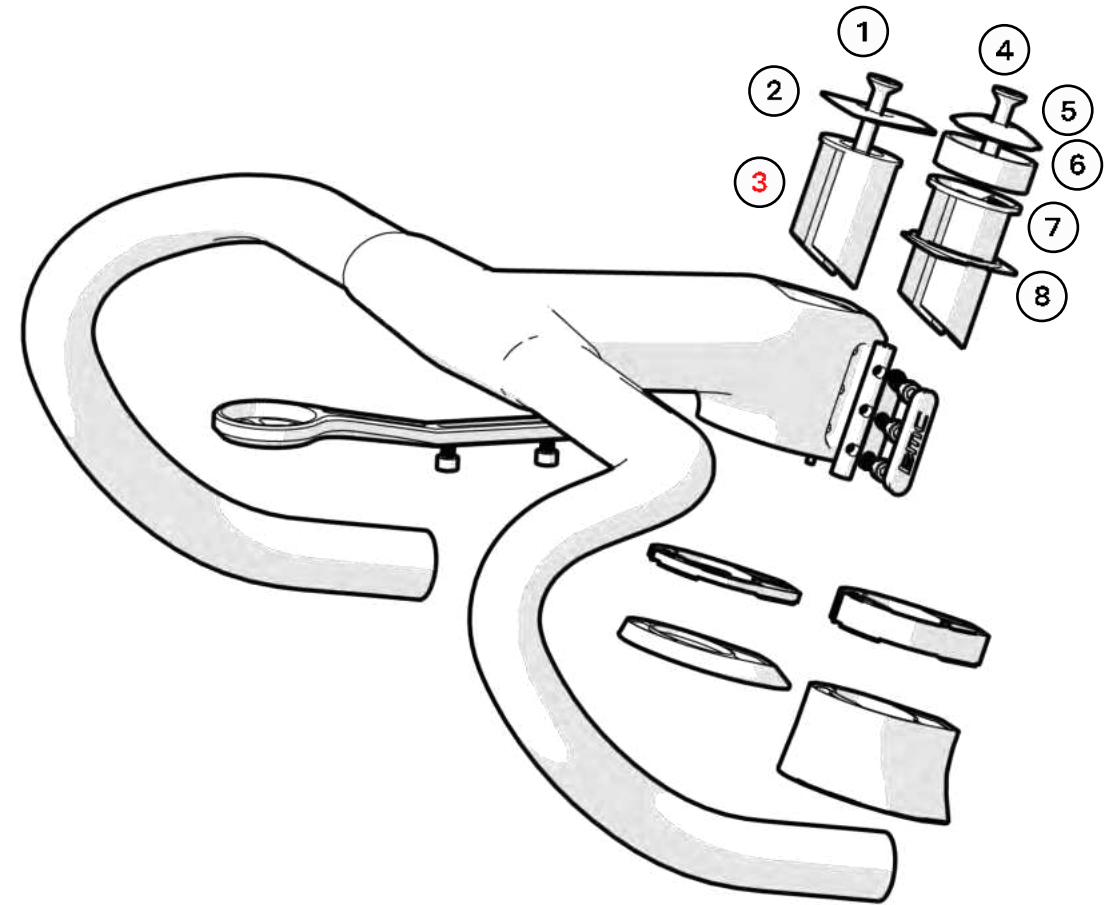

Flush configuration

1. Bolt
2. Flush top cap
3. Steerer wedge

Open configuration

4. Compression bolt
5. Round top cap
6. Standard spacer
7. Lipped steerer wedge for round spacers
8. Shaped top cap for round spacers

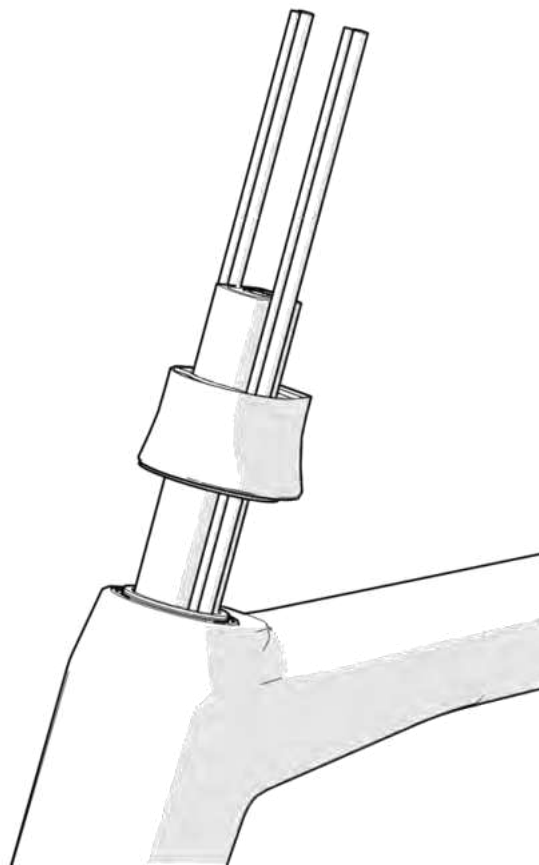

Slide the topcone over fork steerer and hoses.

- Install the spacers
- The two halves of the spacers must well connect and engage with a click

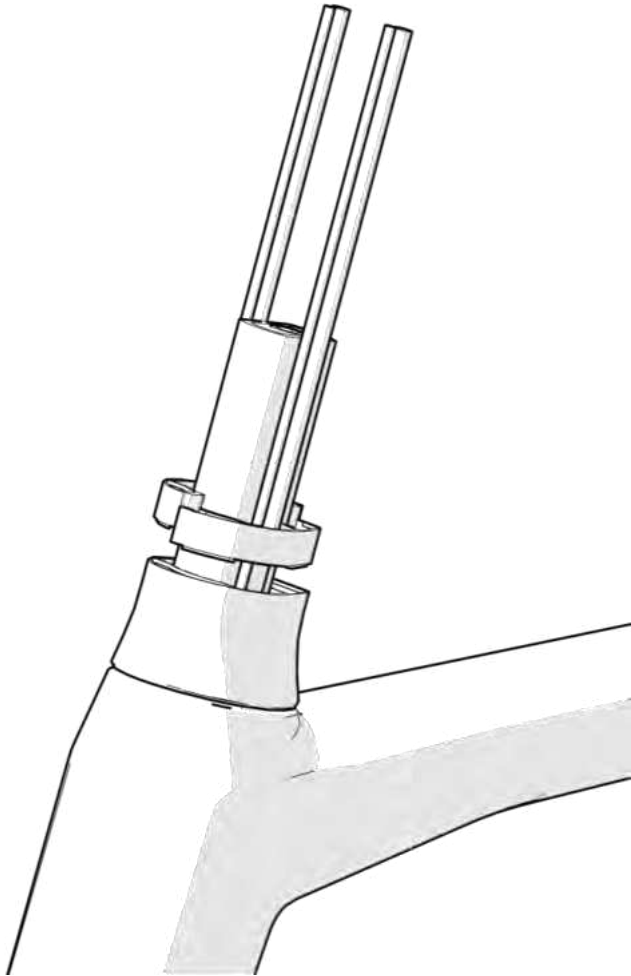

- The two halves of the spacers are not identical!

Ensure the concave face is facing up and the convex one is facing down

- Spacers are locked applying pressure

Spacers can be connected only when correctly oriented

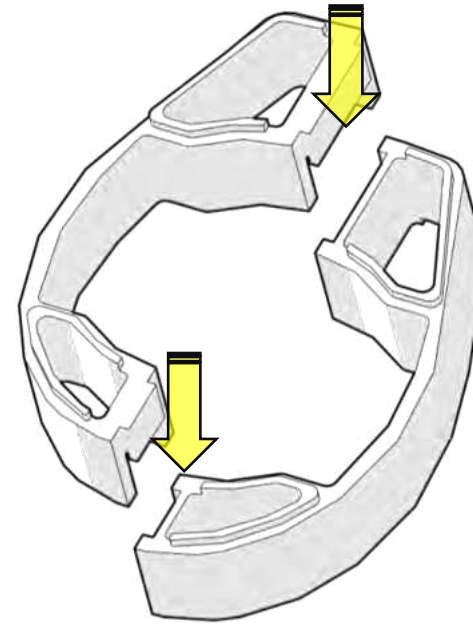

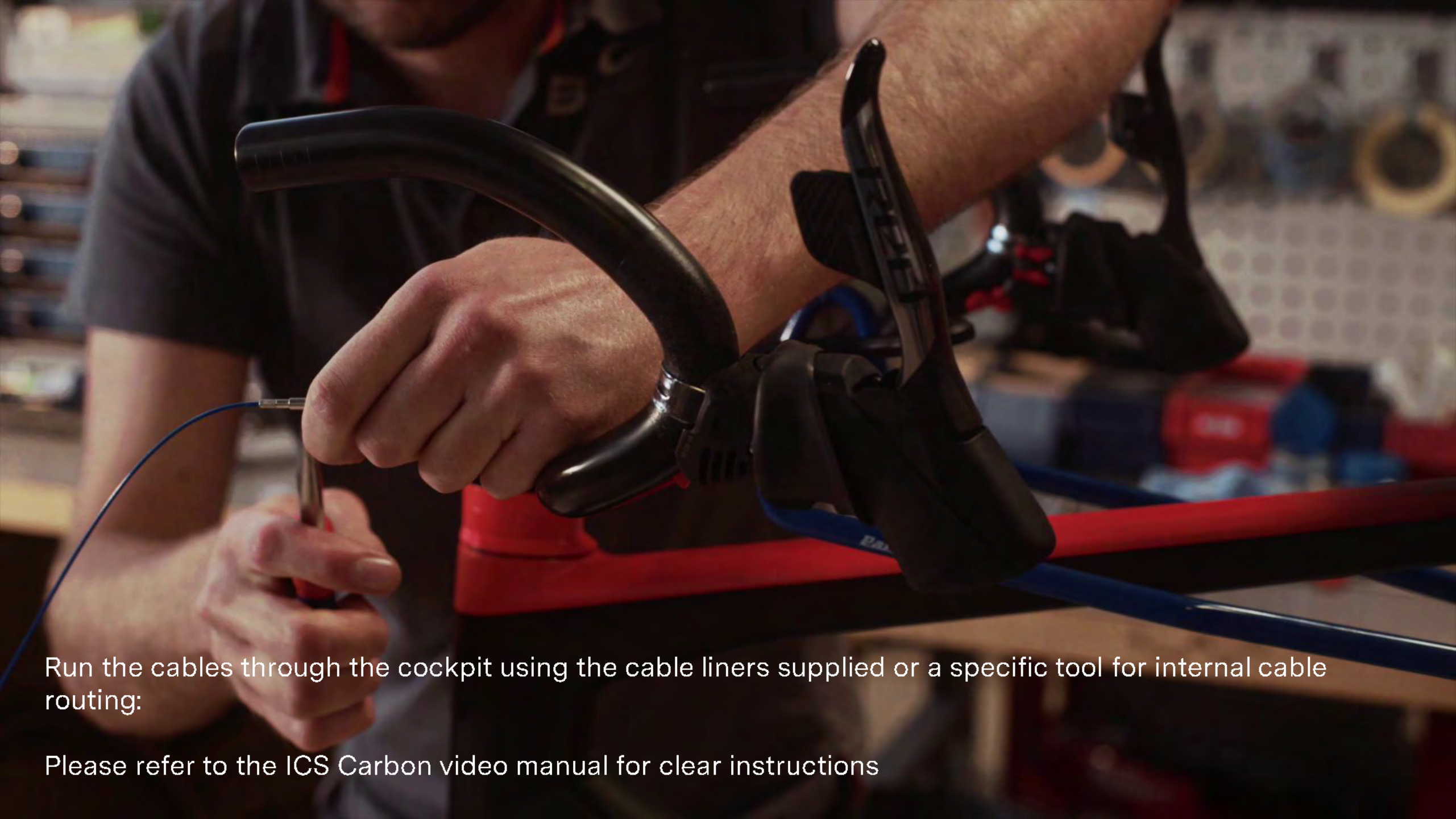

Run the cables through the cockpit using the cable liners supplied or a specific tool for internal cable routing:

Please refer to the ICS Carbon video manual for clear instructions

Install the steerer wedges

- Ensure you are using the correct wedge for open or closed topcap configuration (illustration below)
- Make sure the wedges are aligned correctly (illustration on the side)

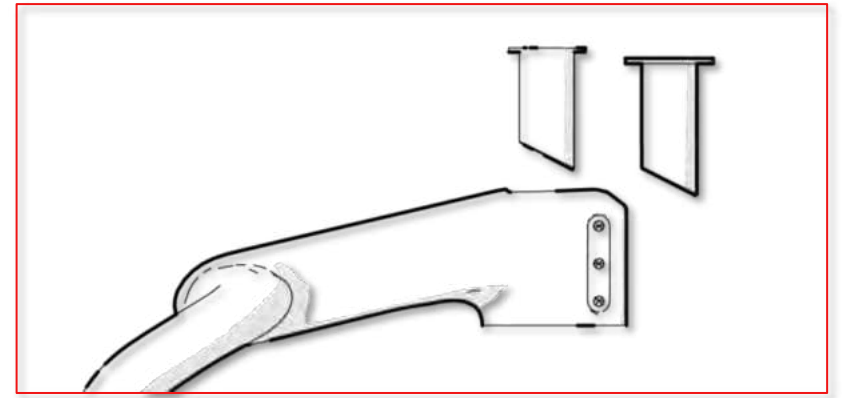

Closed Top Cap

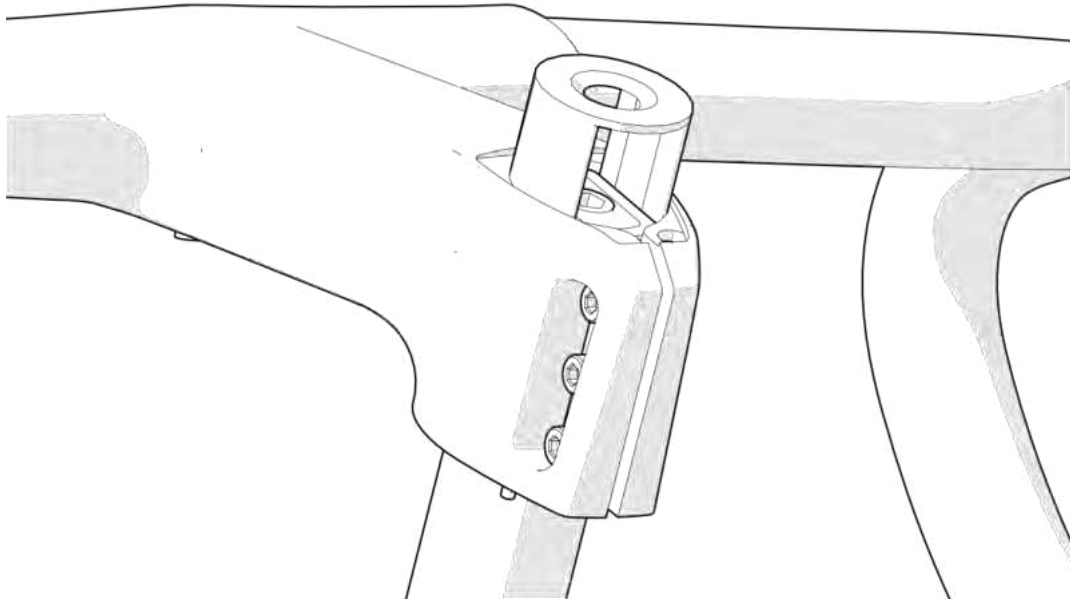

Open Top Cap

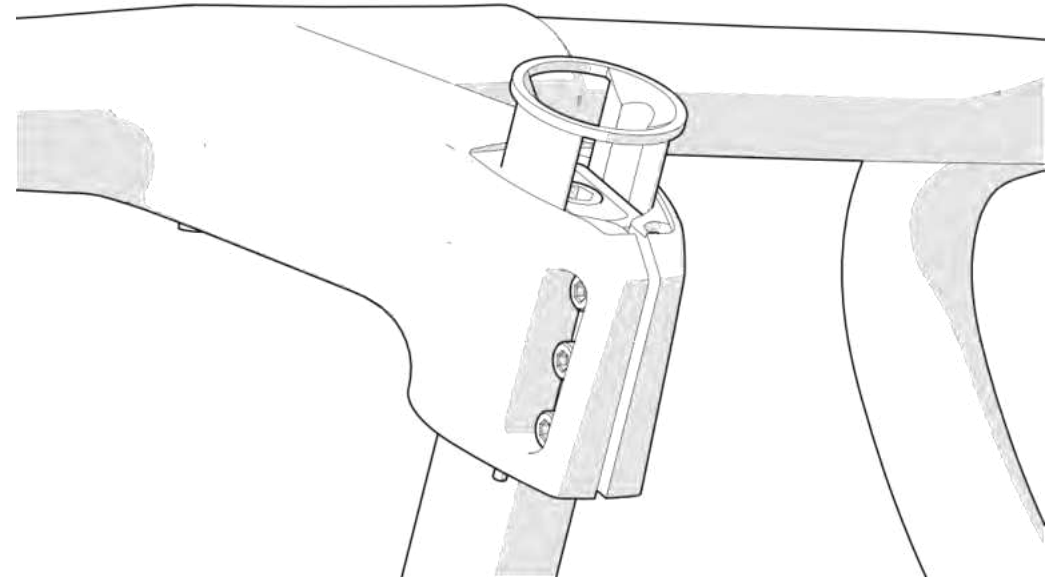

Install the top cap for the selected configuration

Tighten the headset with 4 Nm Torque

- Flush Configuration

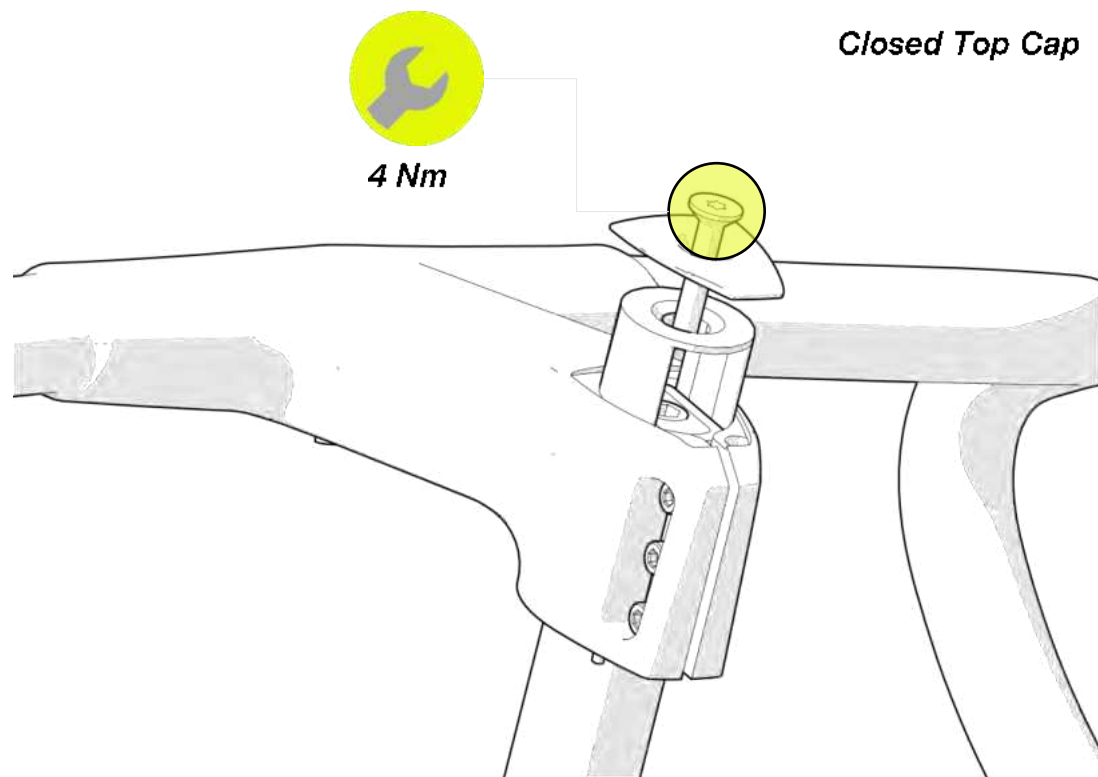

- Open Configuration

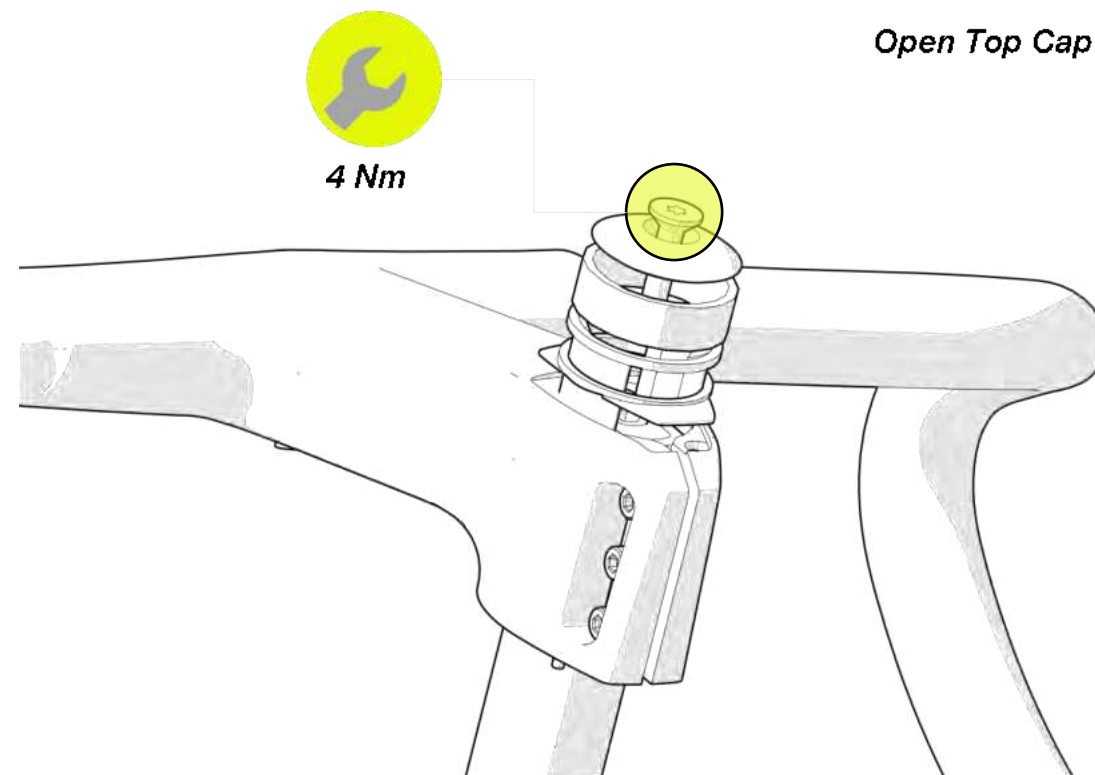

- Tighten the bolts alternately in order to apply torque evenly
- Apply 3 Nm of torque



- Install the bolt cover





ICS2

ICS MTT

ICS 01

ICS 01 0°

Stem Installation

Instructions for 2-piece ICS system

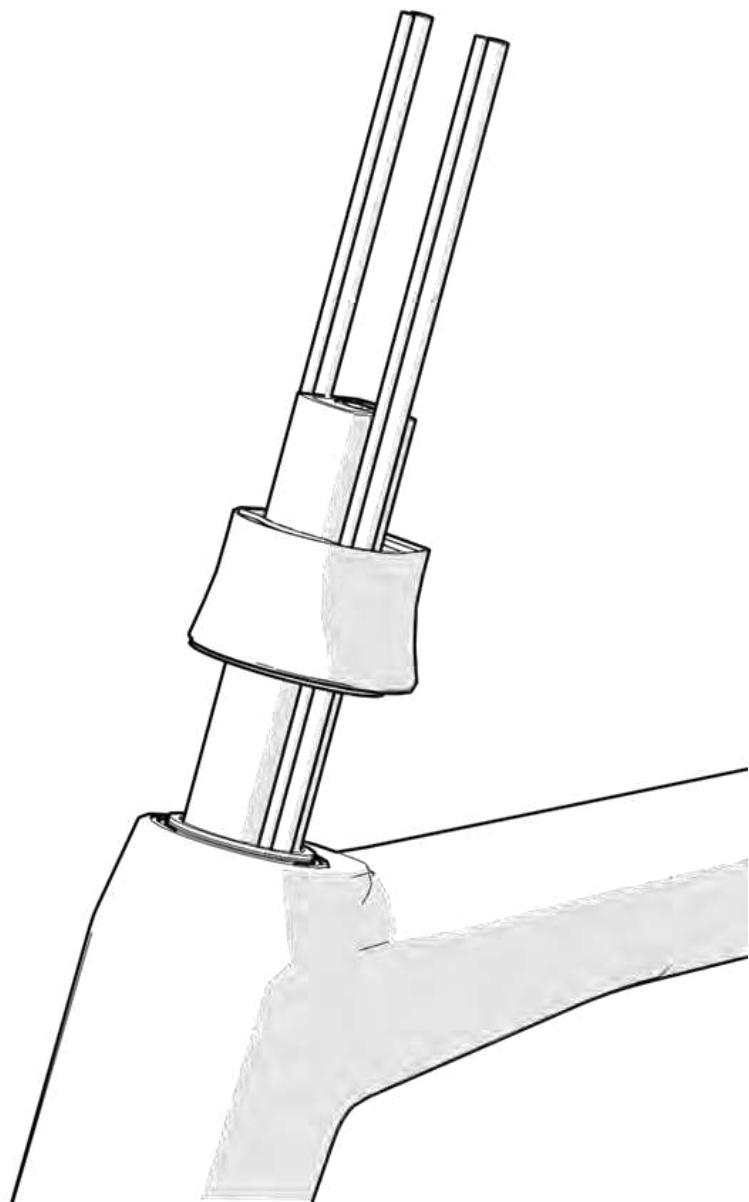

Slide the topcone over fork steerer and hoses.

- Install Spacers
- The two halves of the spacers must well connect and engage with a click

Install cable guide

Make sure the brake lines don't get squeezed between the spacers, cable guide or stem. This could damage the brake lines.

- The two halves of the spacers are not identical!
Ensure the concave face is facing up and the convex one is facing down
- Spacers are locked applying pressure
Spacers can be connected only when correctly oriented

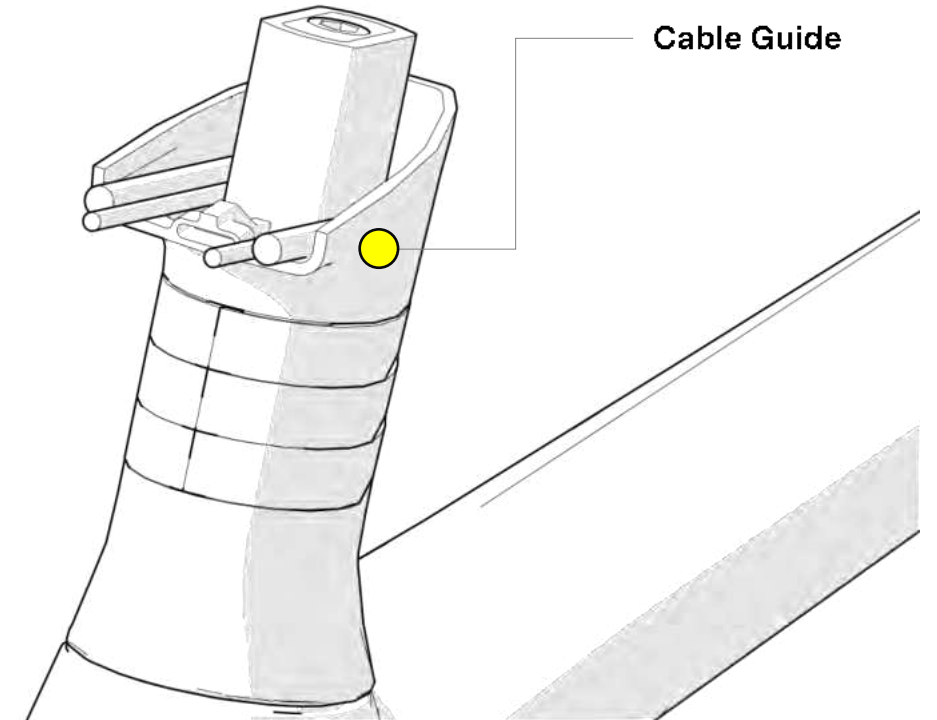
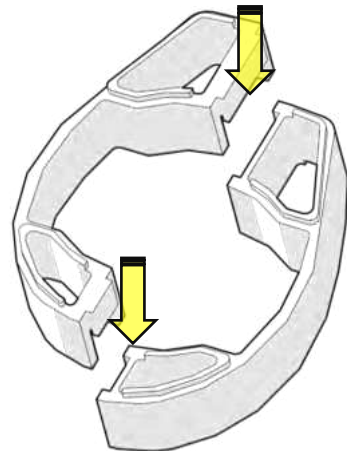
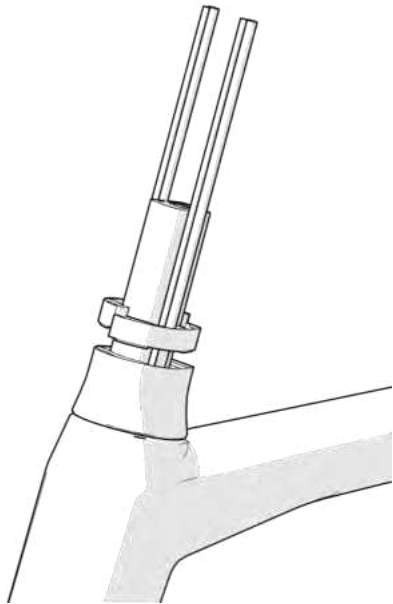

Install stem body

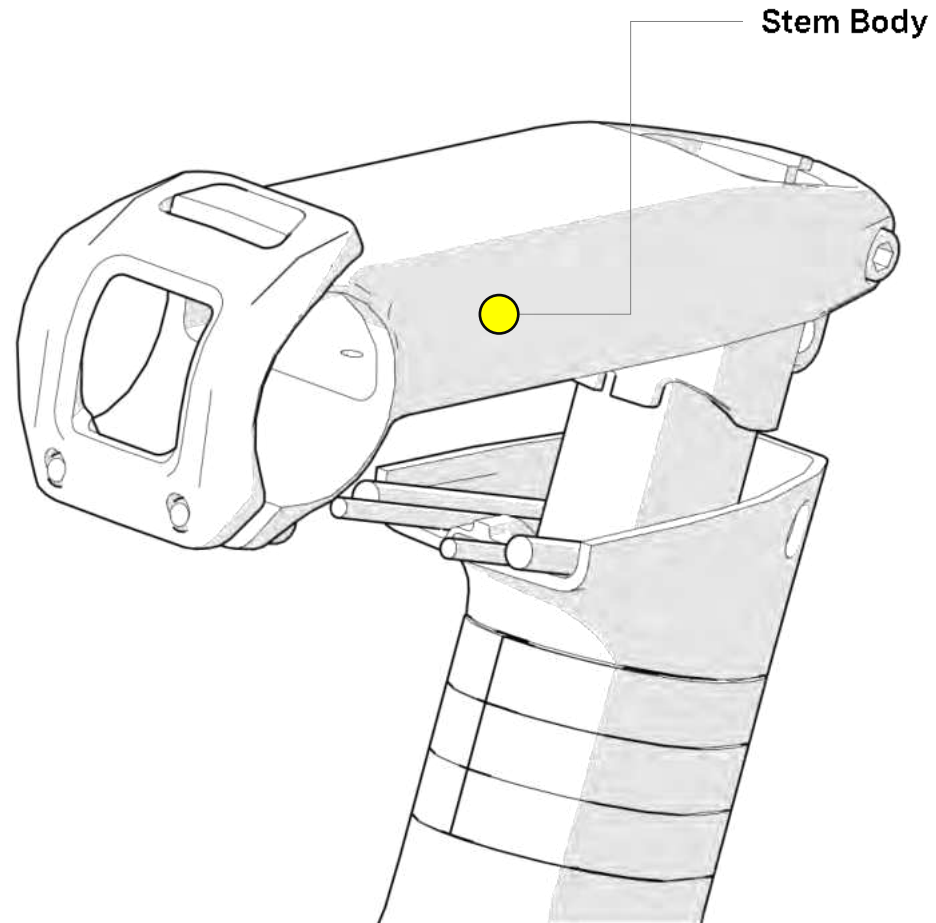

ICS2: make sure that only the upper stem bolt is installed in the stem body at this point.

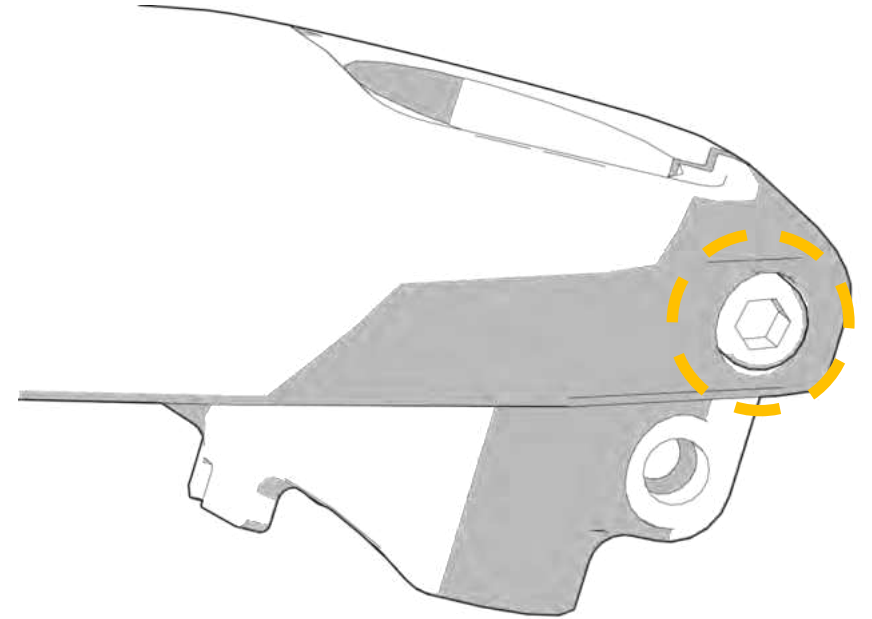

Install the top cap and spacer/top cone configuration you have selected when cutting the steerer

2nd generation ICS Cockpits and Stems feature shaped headset top caps for a cleaner look and can be setup in 2 different configurations.

1. The **flush configuration** provides a perfectly integrated look when the rider knows is ideal fit and decides to cut the fork steerer to a definitive length.
2. If the final fit has not yet been determined, the **open configuration** allows to easily adjust the cockpit height simply adjusting the interlocking spacer stack, the steerer does not have to be cut and round spacers can be used above the stem or cockpit to adjust the headset tension.

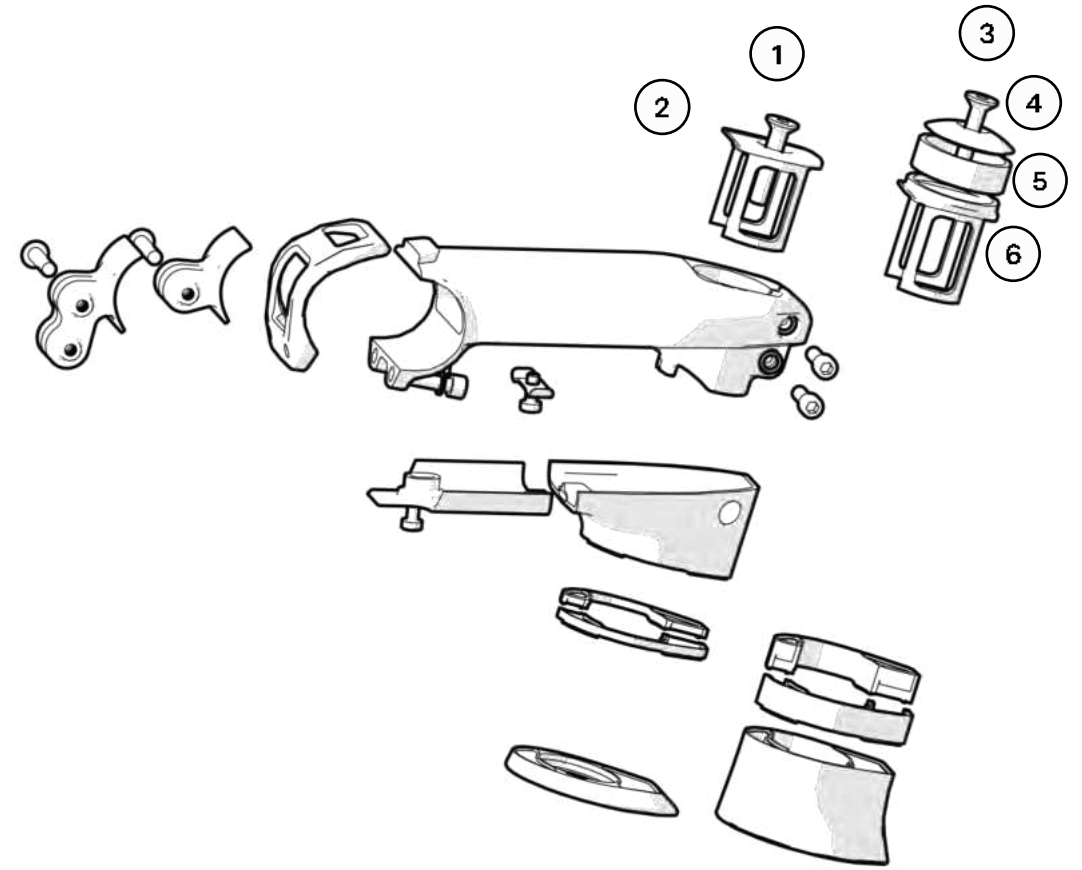

Flush Configuration

1. Compression Bolt
2. Flush Top Cap

Open Configuration

3. Compression Bolt
4. Round Top Cap
5. Standard Spacer
6. Lipped Steerer wedge for Round Spacers

Install topcap and adjust headset play-free

4 Nm

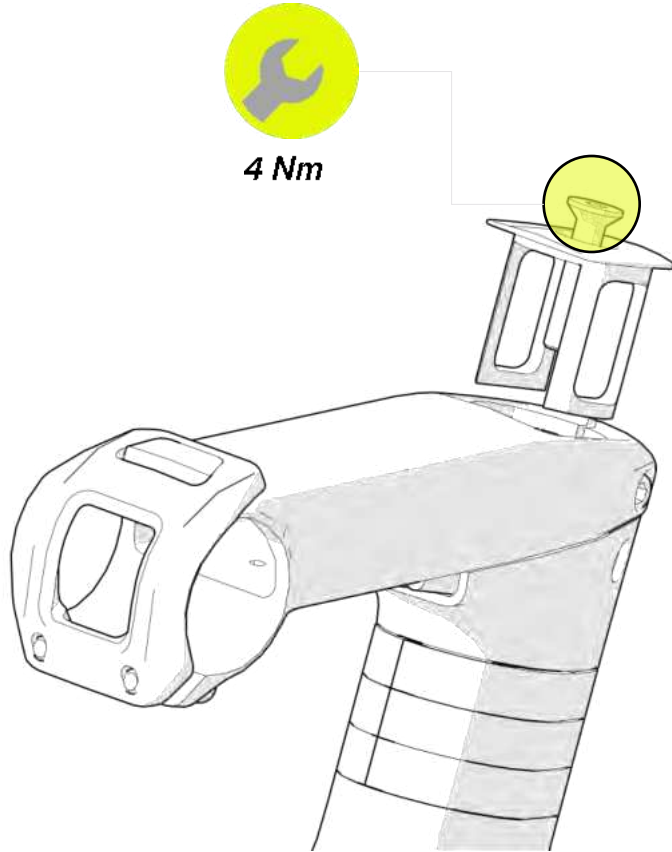

Install lower stem bolt and tighten both bolts with

5 Nm

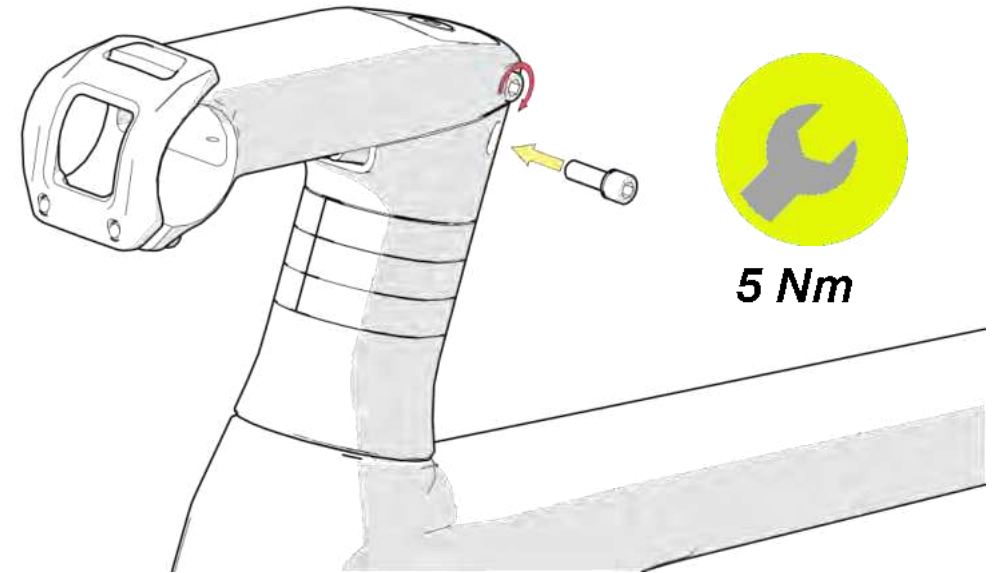

Attach cable in the stem using the cable clip

- Tighten at 2Nm

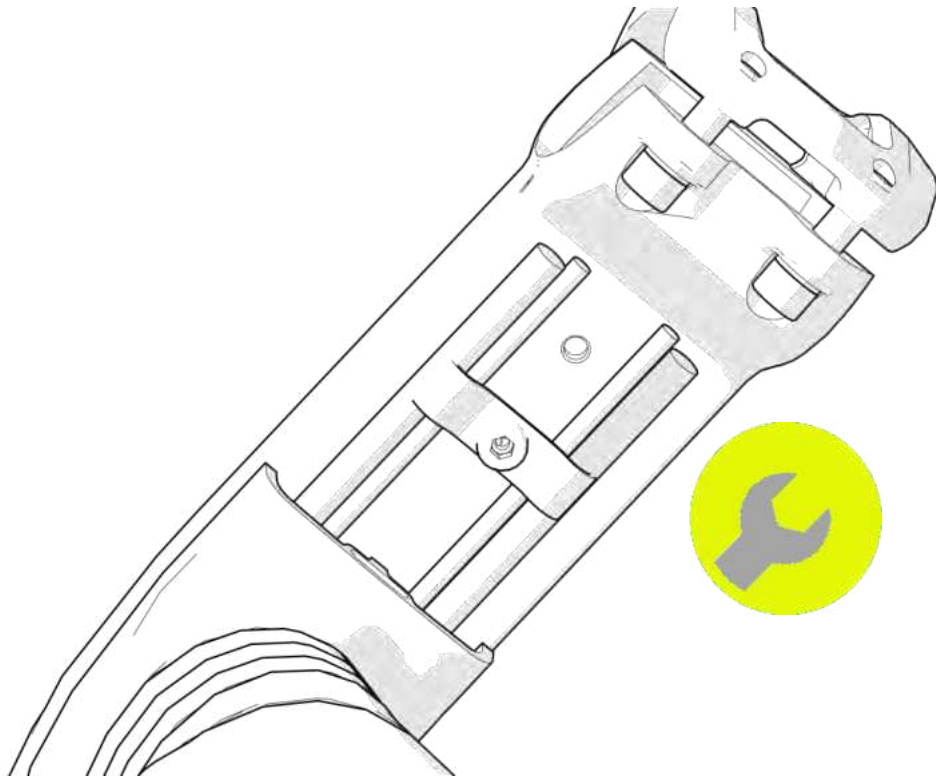

Install cover

- Tighten at 2Nm

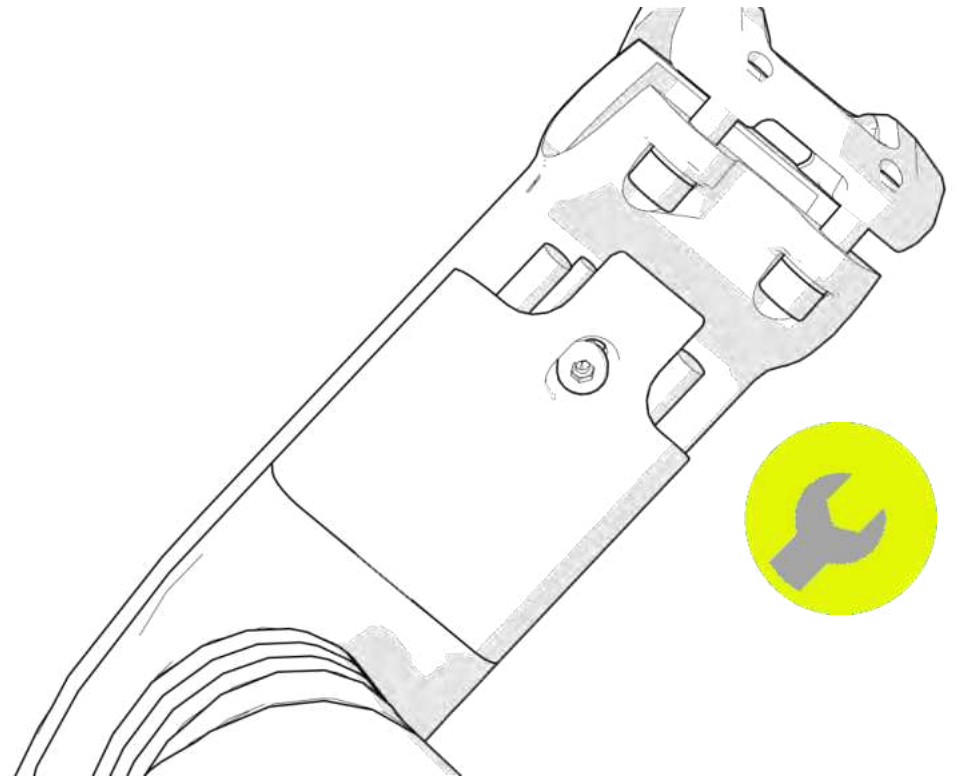

Connect the brake hoses with the levers and proceed with a brake bleed following the brake manufacturer's guidelines.

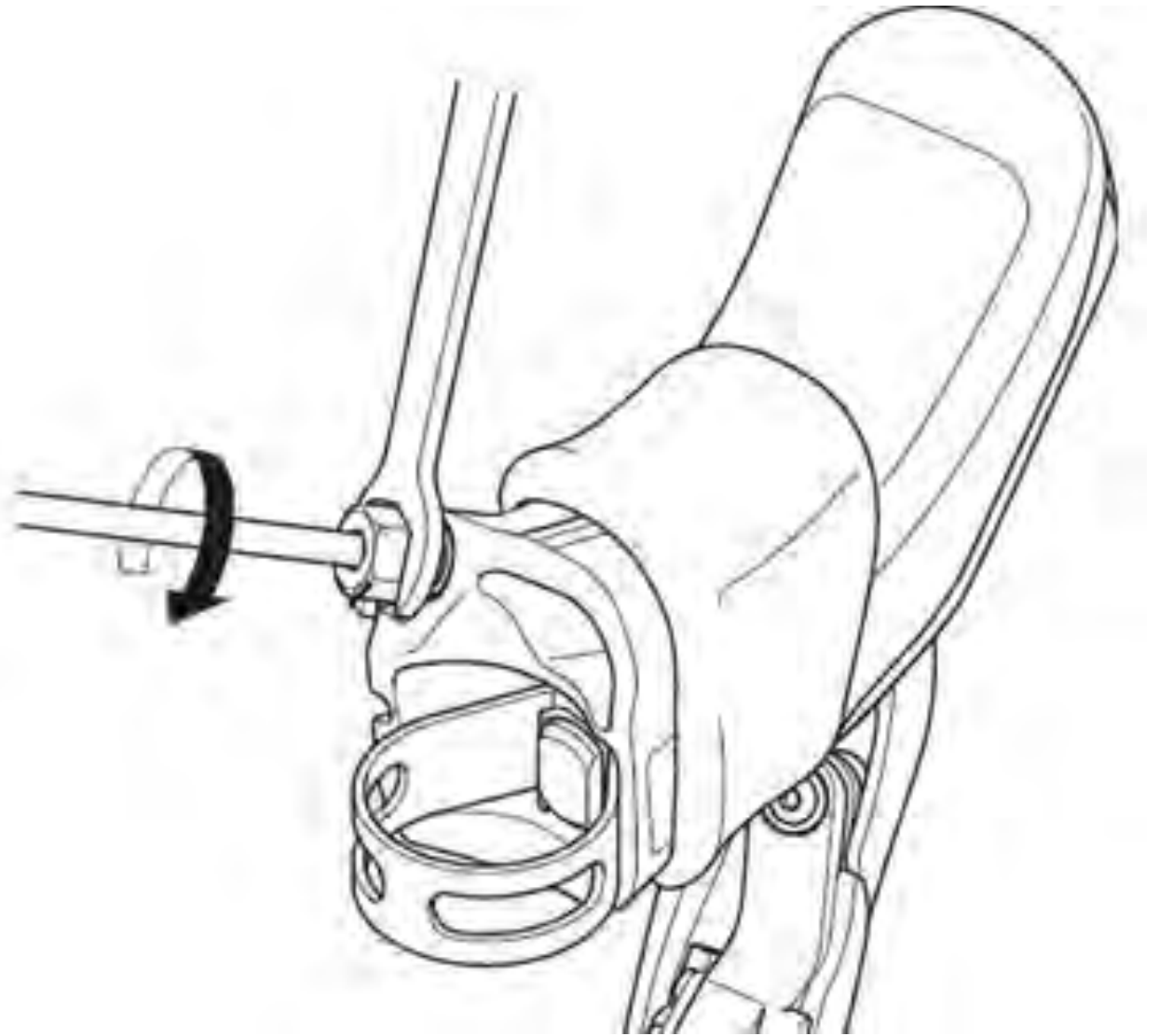

ATTENTION:

Do never rotate the handlebar and stem relative to the Fork!

This would damage the internal brake hoses.

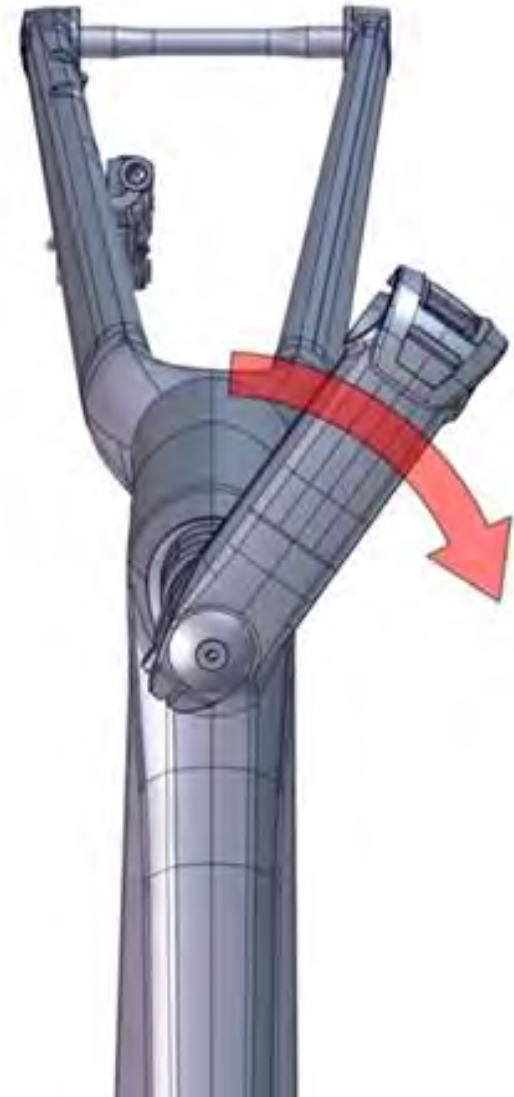

The image shows a black suspension stem assembly for a bicycle, positioned diagonally. In the foreground, there are several small, colored elastomer spacers arranged in a row. The spacers are color-coded: two black, two dark green, two blue, two orange, and two yellow. The text 'ICS MTT x Redshift Suspension Stem' is overlaid in white, bold font, and 'Elastomer Configuration' is overlaid in a smaller white font below it.

ICS MTT x Redshift Suspension Stem

Elastomer Configuration

CUSTOMISATION

The ICS MTT suspension Stem can be customized to provide a different feel by changing the elastomer configuration:

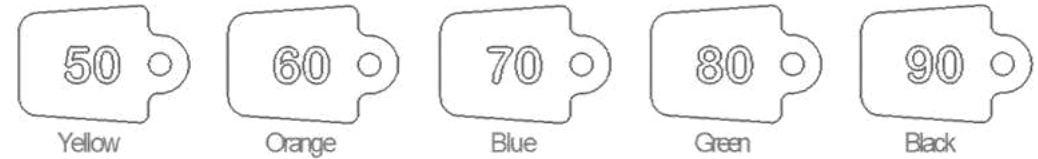



- Softer Elastomers: plusher riding feel, reduced terrain feedback
- Harder Elastomers: direct riding feel, more terrain feedback

The ICS MTT Suspension Stem's stock configuration varies based on length:

Stem Length	Elastomer combination (Elastomer 1-Elastomer 2)
72mm	60-70
80mm & 90mm	70-90
100mm & 110mm	80-90

The elastomer combinations can be freely mixed and matched, a list of suggestions are shown below:

Drop Handlebars 				Flat Handlebars 			
Rider Weight		Elastomer 1	Elastomer 2	Rider Weight		Elastomer 1	Elastomer 2
lbs	kg			lbs	kg		
< 115	< 52	60	50	< 135	< 61	50	none
115 - 135	52 - 61	70	50	135 - 185	61 - 84	60	none
135 - 155	61 - 70	70	60	185 - 215	84 - 98	70	none
155 - 185	70 - 84	80	50	> 215	> 98	60	50
185 - 205	84 - 93	80	70				
> 205	> 93	90	50				

CHANGING THE ELASTOMER CONFIGURATION

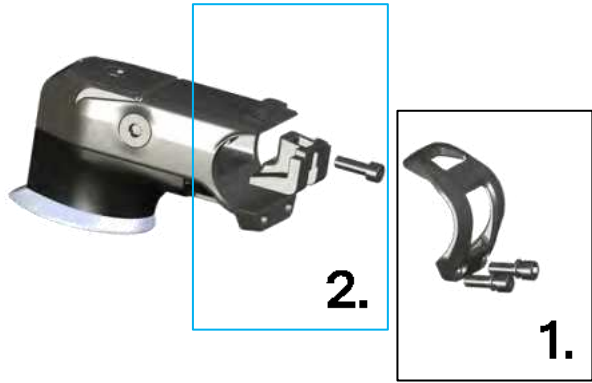

1. Loosen and remove the faceplate bolts
2. remove the faceplate and handlebar (if installed).
3. Loosen and completely remove the preload bolt and wedge.

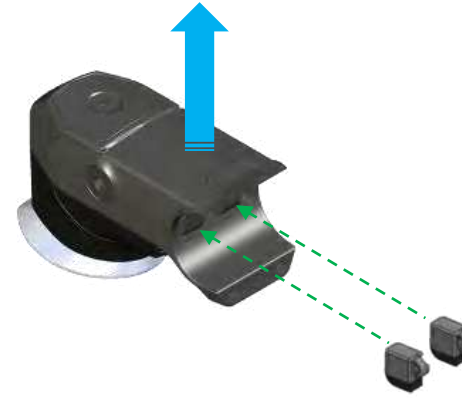

5. Select an elastomer combination from the chart on the previous page and insert the appropriate elastomers into one or both upper elastomer pockets.

- It may help to push the stem body to the top of its travel while inserting the elastomers.

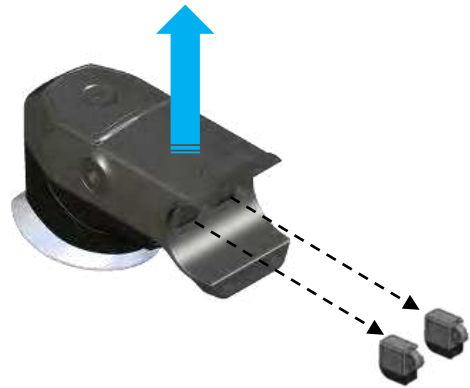

4. Pull upward on the stem and remove the elastomers from inside the stem.

- You may need to use the small end of your hex wrench to hook the handle of the elastomer to pull it out.

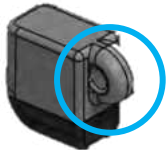

- Be sure to insert the elastomers in the orientation shown below (handle towards the outside), so as not to interfere with the preload wedge installation.

✓
Elastomer handle(s)
outside.
Elastomer(s) above
support.

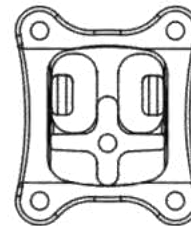

✗
Elastomer
handle(s)
inside

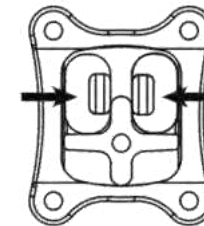

✗
Elastomer(s)
below
support

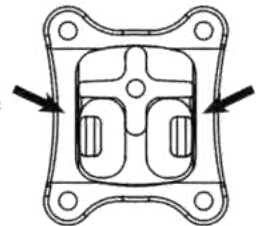

CHANGING THE ELASTOMER CONFIGURATION



6. To re-install the preload wedge, apply downward force to the end of the stem tube

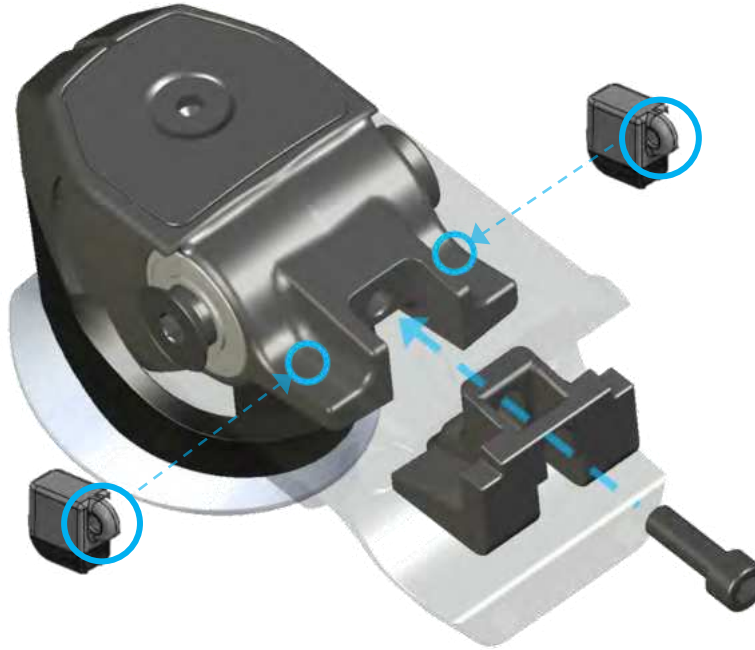

7. Align the preload bolt with the threaded hole inside the stem body. Keeping the bolt head as low and centred as possible, begin turning the preload bolt.
- If you encounter resistance in the first turn, unscrew the bolt and try again: cross-threading may occur if the when engaging the threads bolt is not aligned with hole.



8. Apply grease to the faceplate bolts and ensure that a washer is installed beneath the head of each bolt.
9. Position the handlebar in the stem and install the faceplate by lightly tightening the faceplate bolts.
10. Rotate the handlebar to the desired angle and tighten the faceplate bolts gradually (1/4 turn at a time) to a torque of 5.0 Nm.



Technical Manual

1st Generation ICS Stems

- ICS Aero
- ICS01
- ICS01 0°

Stem Parts*

Integrated Cockpit Stem (ICS01)

ICS01 Stem (90/100/110/120/130)	1
Stem Faceplate	2
Cable guide	3
Stack spacers	4
IC Fork inserts	5
Cable cover	6
Cable clamp	7
Di2 Junction A mount (optional)	8

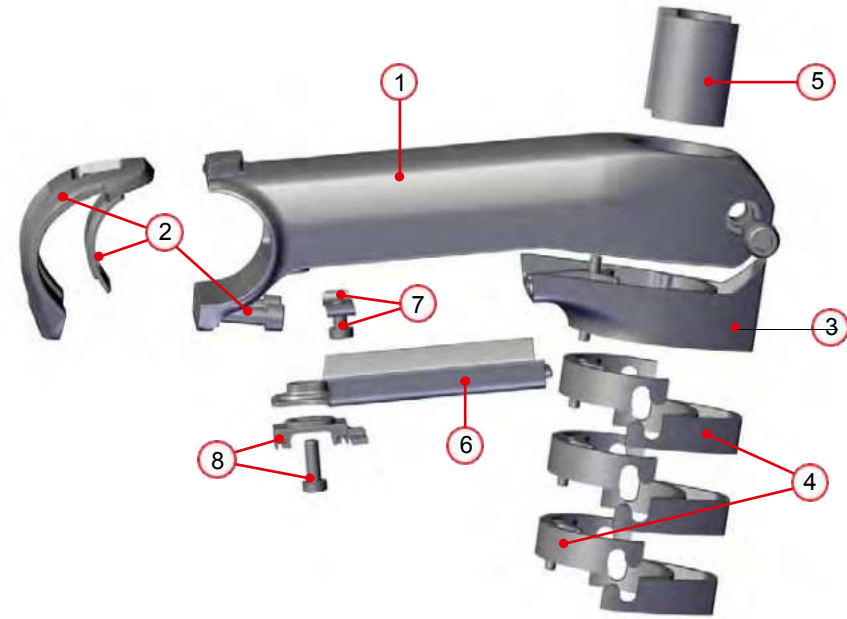

* The stem assembly is identical for ICS01, ICS01 0° and ICS01 Aero

Frameset Assembly

Cable Routing

Brakes

Start the housing routing at the caliper and pass to the front

The rear brake hydraulic housing will pass UNDER the bottom bracket

Install the provided foam sleeve on the rear brake housing in the downtube

It is recommended to assemble the caliper-end hydraulic system (connector insert, olive, and inserting the threaded connector bolt) – this will help hold the hose in place during future assembly steps



Frameset Assembly

Cable Routing

Drivetrain

- Install proper DTi frame fittings for your frame and drivetrain

In the case of electronic systems, we strongly recommend assembling the system and checking all connections before routing cables through the frame.

Electronic Drivetrain



Downtube covers



Rear derailleur cable exit



BB cover

Mechanical Drivetrain

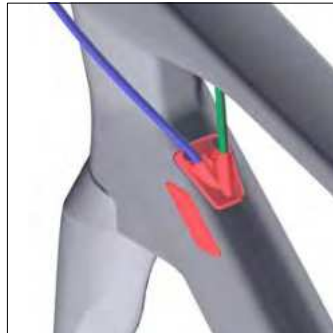

Drivetrain housing exit



Rear derailleur cable stop



Rear derailleur cable stop

Frameset Assembly

Preparing and installing fork

- Install the headset components, cable guide, stem, and steerer inserts.
- Gently compress the system together and tighten the stem steerer tube clamp bolt gently.

Warning

Tightening the stem steerer clamp bolt without installing the steerer spacers can compromise the integrity of the steerer tube, potentially leading to serious injury.

- Using a felt-tipped marker, make a mark on the steerer tube at the top of the stem.
- After verifying handlebar position, and marking stem height, uninstall the fork and headset from the frame.

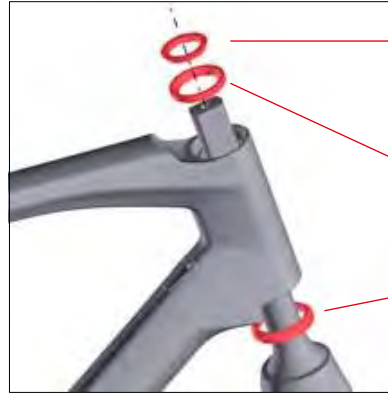

- Install steerer compression ring
- Install upper bearing
- Install lower bearing & fork



INSTALL STEERER SPACERS BEFORE TIGHTENING STEM CLAMP!

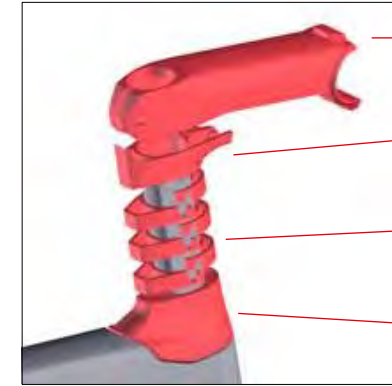

- Install stem
- Install cable guide
- Install spacers
- Install headset top cap



- Mark steerer at top of stem

Frameset Assembly

Fork Cutting

- Use the mark on the steerer tube to assign a proper cutting location.

Cut the steerer tube 3mm below the mark!

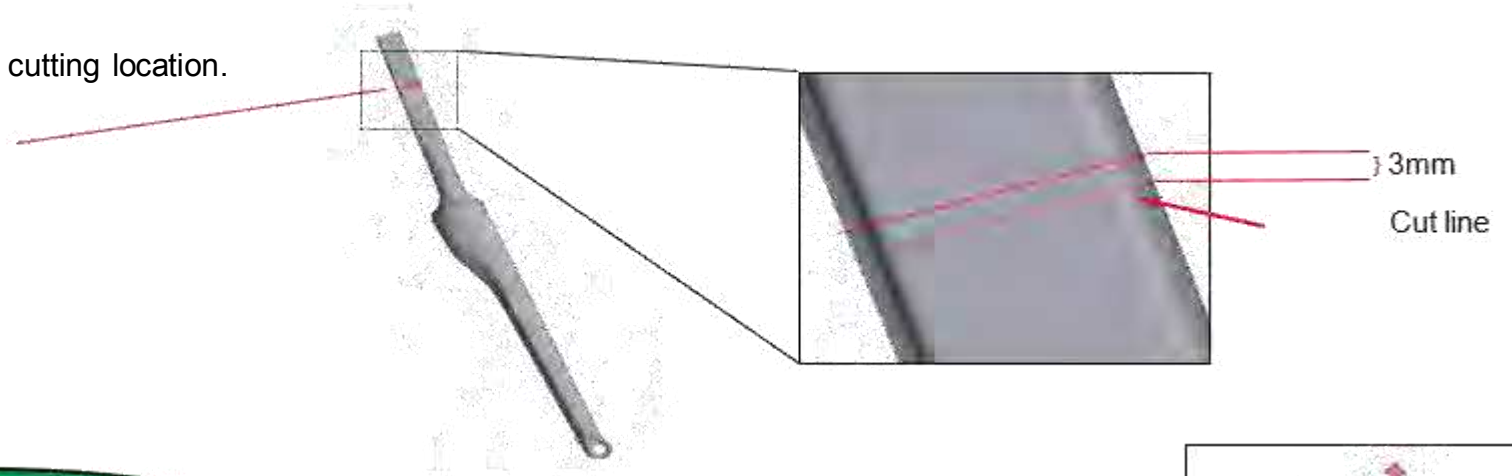

Install self-tapping compression nut

- The 01 IC Fork comes with an internal channel which receives a self-tapping compression nut.
- Install the self-tapping compression nut, making certain it remains aligned with the steerer
- Tighten until the top of the compression nut is flush with the top of the fork

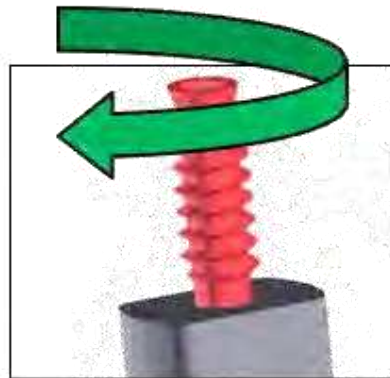

Route brake housing

- Route the housing through the internal guide, starting at the axle dropout and working towards the steerer tube.
- It is recommended to assemble the caliper-end of the hydraulic system (connector insert, olive, and inserting the threaded connector bolt) – this will help hold the hose in place during future assembly steps.

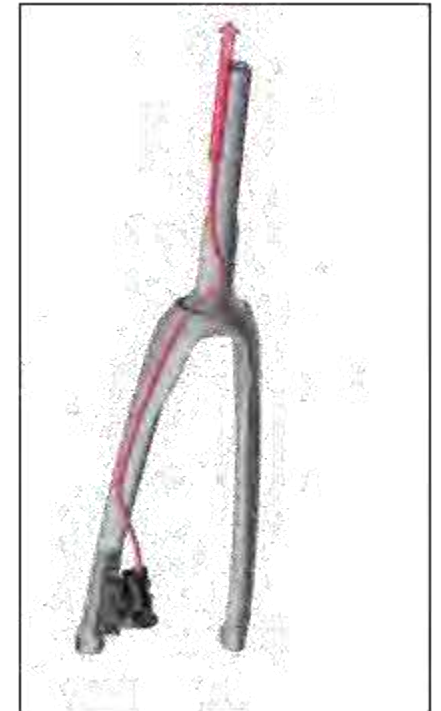

Installing headset and ICS Stem

- Install the fork and headset using grease on all contact surfaces
- Arrange and align cable routing, brake lines can be positioned in the opposite position (Left – Rear, Right – Front)
- Install headset top cone (high or low stack) and spacers
- Install stem cable guide and gently position cables downward
- Install ICS Stem and steerer tube inserts
- Install top cap and compression bolt

3Nm max torque

- Install stem steerer clamp bolt - grease required

7Nm max torque

- Install stem cable clamp
- Install stem cable cover
- Install optional Di2 Junction Box

Completing the assembly

- Assemble and adjust brake and drivetrain equipment per manufacturer's instructions



Route the front brake housing to the non-drive side

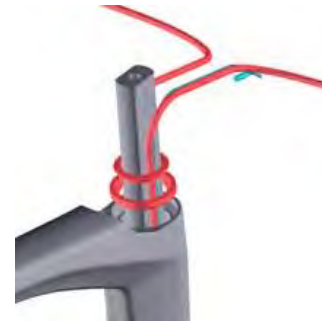

Install bearings and compression ring – cables will sit securely on flat sides of steerertube

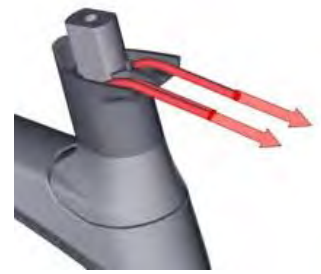

Install top cone, spacers and cable guide
Gently fold cable downward



Install stem and steerer inserts



4Nm max torque!
Install top cap and compression bolt



**7Nm max torque!
(grease required)**
Install stem steerer clamp bolt - grease required!



Install cable clamp, cable cover and Di2 junction box mount (optional)



Install faceplate and faceplate cover
make sure the top faceplate 'puzzle' clamp is securely engaged



Install Di2 junction box (optional)



DEVICE MOUNTS

ICS Stems and ICS Aero

The alloy computer mount is compatible with all ICS Stems (1st and 2nd generation, including ICS Aero) and features Garmin and Wahoo inserts

- Single and Double brackets are available to allow the installation of additional devices that use the Go-Pro interface.
- The alloy brackets (nr.1, 2) are installed between the stem faceplate and the handlebar as shown in the illustration below
- **ICS Aero uses a specific mount since the ICS Aero Bar and ICS Aero Stem have different dimensions**

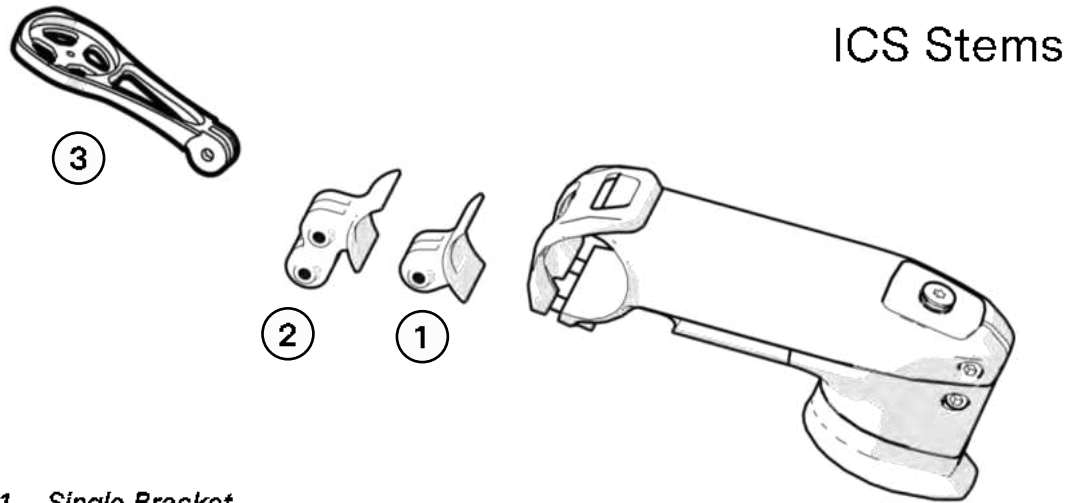

1. Single Bracket
2. Double Bracket
3. Alloy Computer Mount (Garmin and Wahoo inserts)

Correct installation of the alloy bracket

ICS Carbon & ICS Carbon Aero

- The alloy computer mount features Garmin and Wahoo inserts and allows the installation of additional devices that use the Go-Pro interface.
- The Computer mount can be adjusted in order to adapt to different device sizes
- Note: the washers must be positioned between the bolt and the computer mount.
- Tighten at 2.5 Nm
- **The ICS Carbon Aero device mount has slightly different dimensions but identical features**

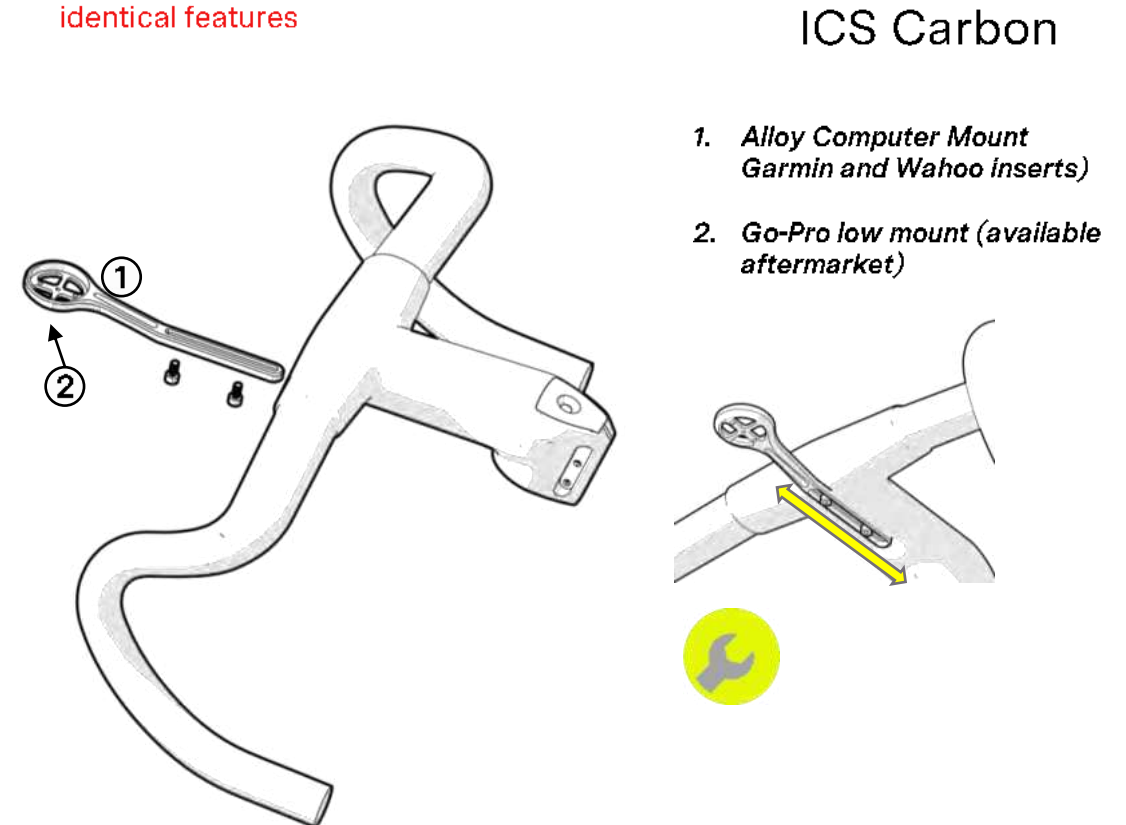

1. Alloy Computer Mount (Garmin and Wahoo inserts)
2. Go-Pro low mount (available aftermarket)

ICS Aero & ICS Carbon Aero Clip-On Extensions

Installation Guide

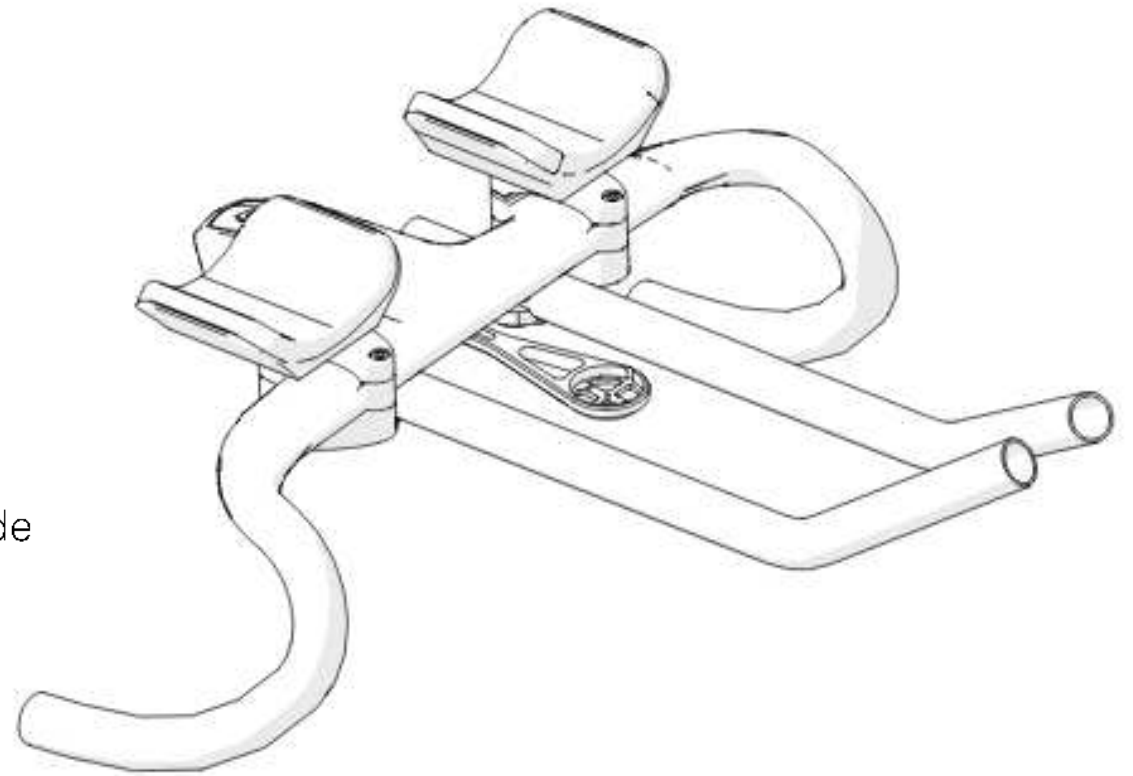

PART LIST

	ITEM #
ICS CARBON AERO	XXXX
ICS AERO	30000749

NUMBER	PART
1	LEFT Upper Clamp Marked As "L" On The Inner Face
2	LEFT Lower Clamp Marked As "L" On The Inner Face
3	LEFT Extension Body
4	Extension Clamps
5	M5 X 25 (incl 5x8.5mm Washer)
6	M4x12 (incl. 4x7mm Washer)
7	M4x20 (incl. 4x7mm Washer)
8	RIGHT Upper Clamp Marked As "R" On The Inner Face
9	RIGHT Lower Clamp Marked As "R" On The Inner Face
10	RIGHT Extension Body
11	Assembly Guide (remove after assembly)
12	Assembly Guide Bolts (M6 X 12) And O-ring 5.6x1.8
13	Arm Rests
14	Arm Pads
15	M6 Bolt M6 X12
16	Carbon Extensions

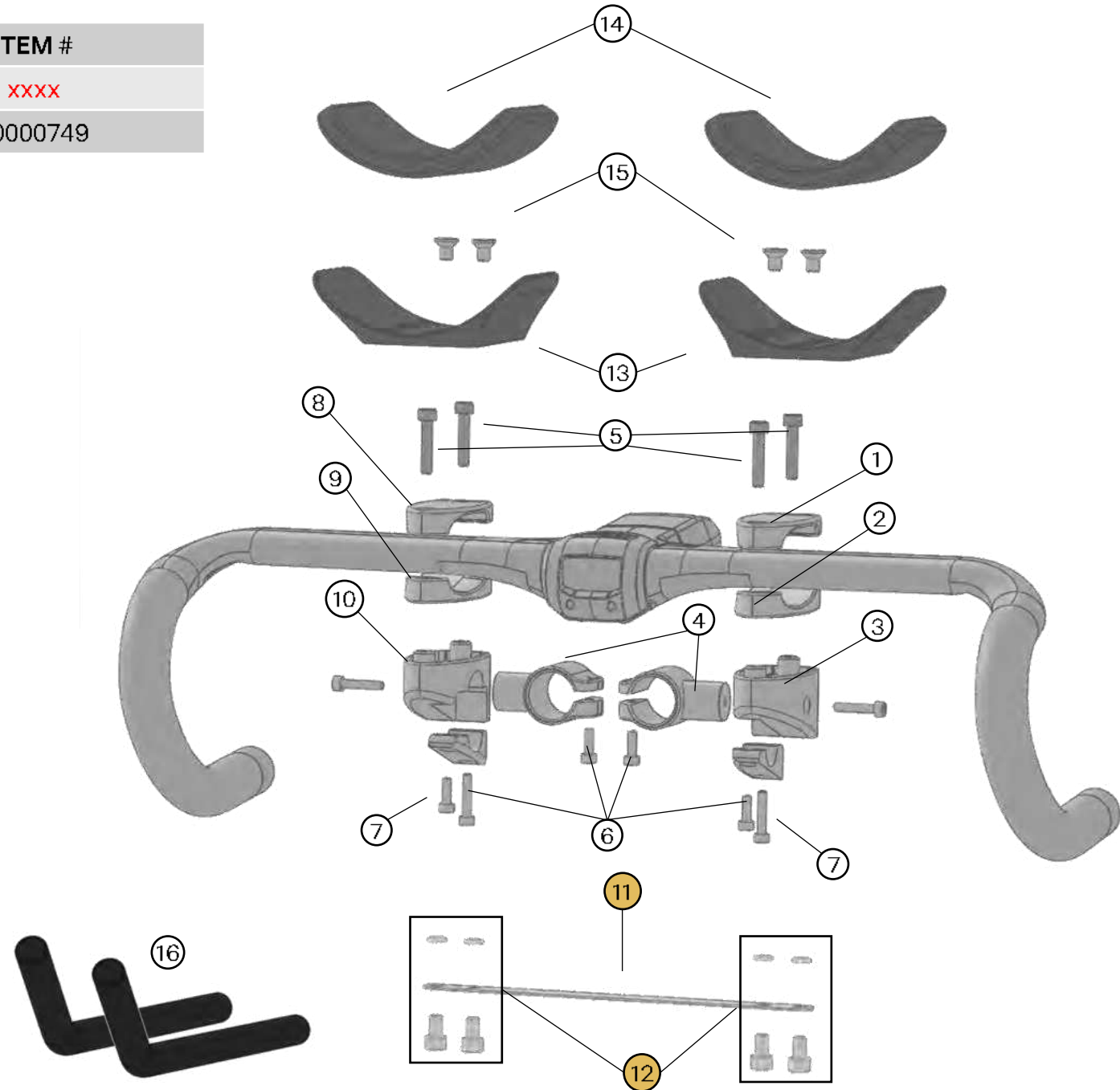

MOUNTING OPTIONS

It is possible to mount the clip-on extensions in two different positions, reversing the position of the components:



1. LOW POSITION
The extensions are positioned below the handlebar

MOUNTING OPTIONS



2. HIGH POSITION

The extensions are positioned above the handlebar

EXPLODED VIEWS

HIGH POSITION



LOW POSITION

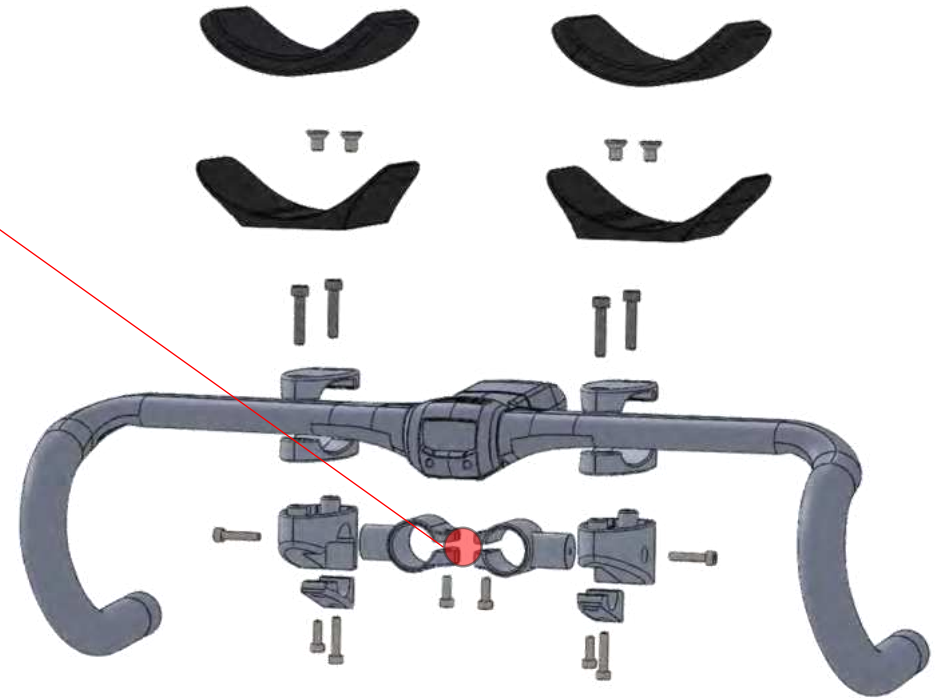

IMPORTANT NOTE

Install the assembly guide to ensure the correct position of the tri extensions on the handlebar. The guide should be removed once the clip-on extensions are installed.



INSTALLATION ON THE COCKPIT:

Use the notches on the assembly guide to ensure the correct positioning and centering of the handlebar clamps.

The center-to-center distance between the extensions is set at 100mm.



Please note that there is a gap in the clamp when correctly tightened (5 Nm).

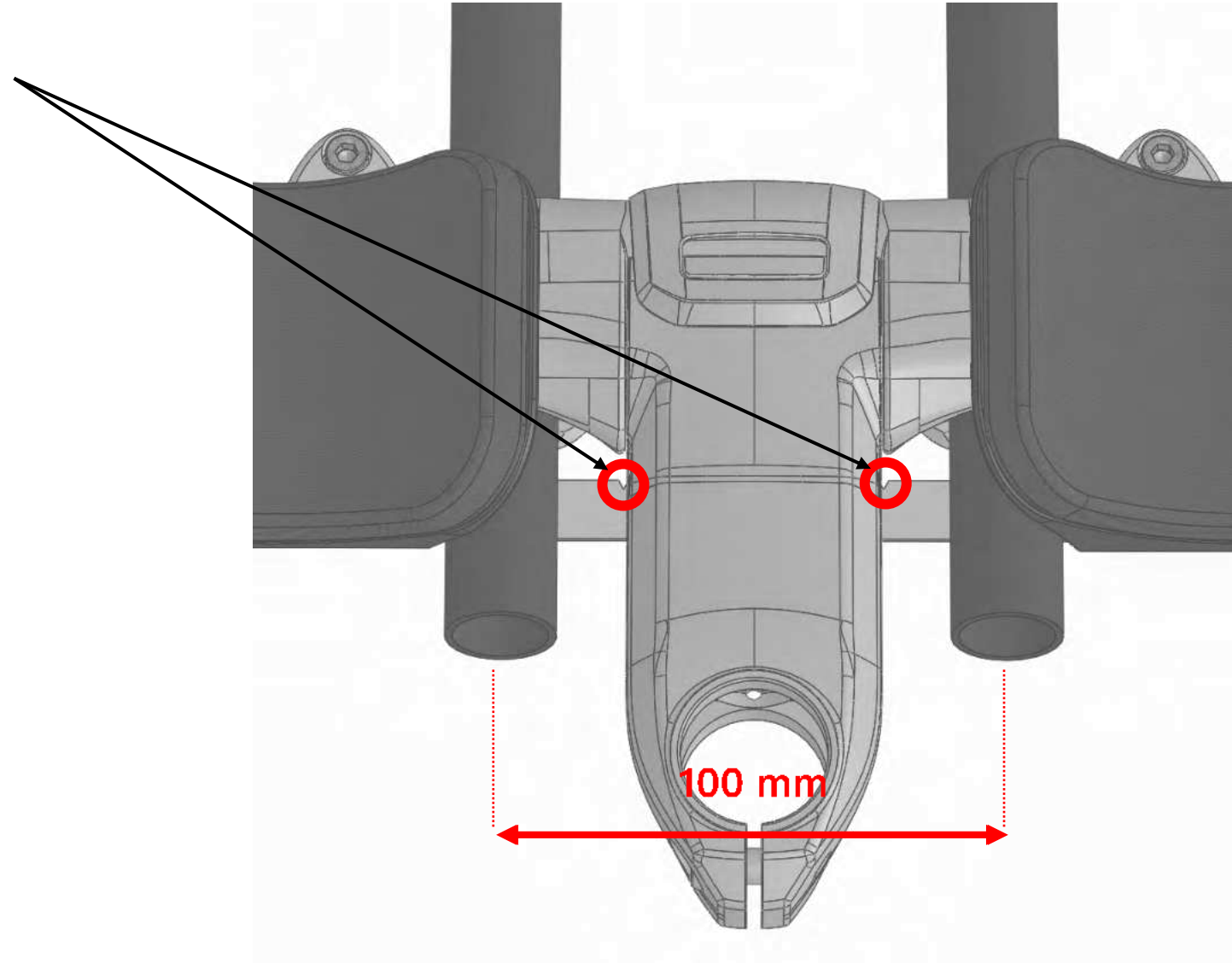

Refer to the torque values displayed below when tightening the assembly:



Apply grip paste on the extension clamp cylinders

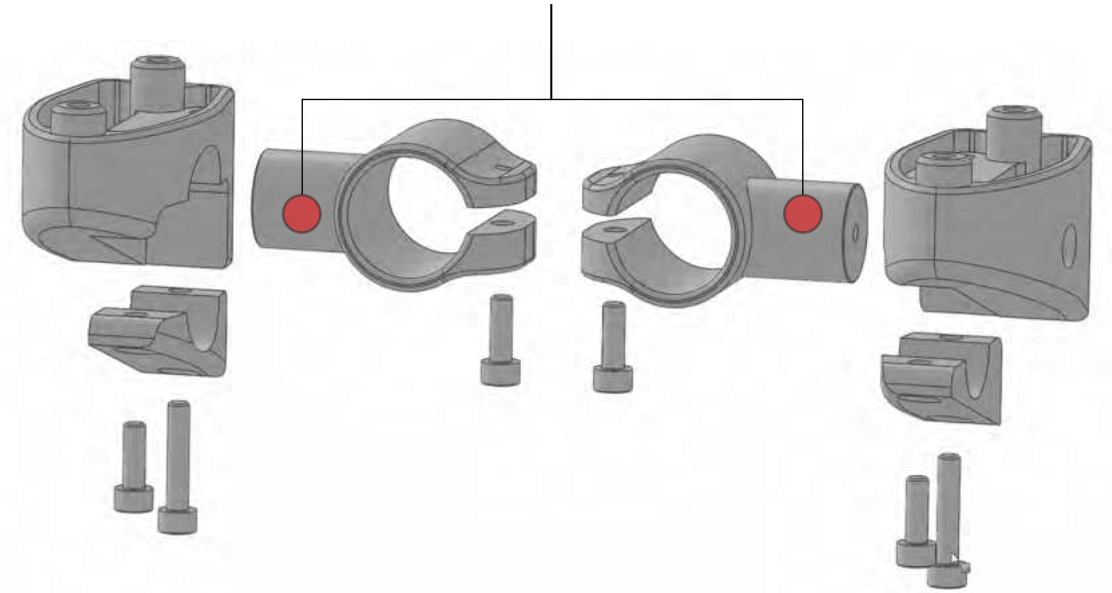

The arm rest position can be adjusted using different mounting holes

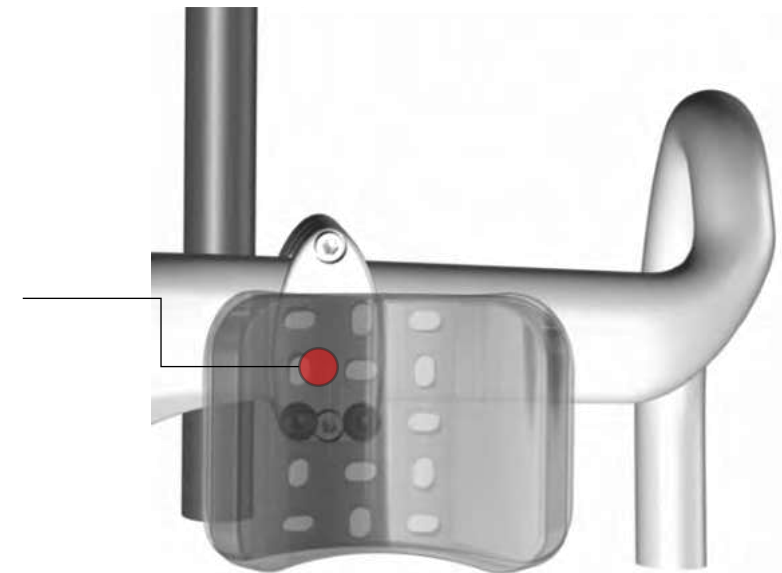



SPARE PARTS

ICS CARBON COCKPIT

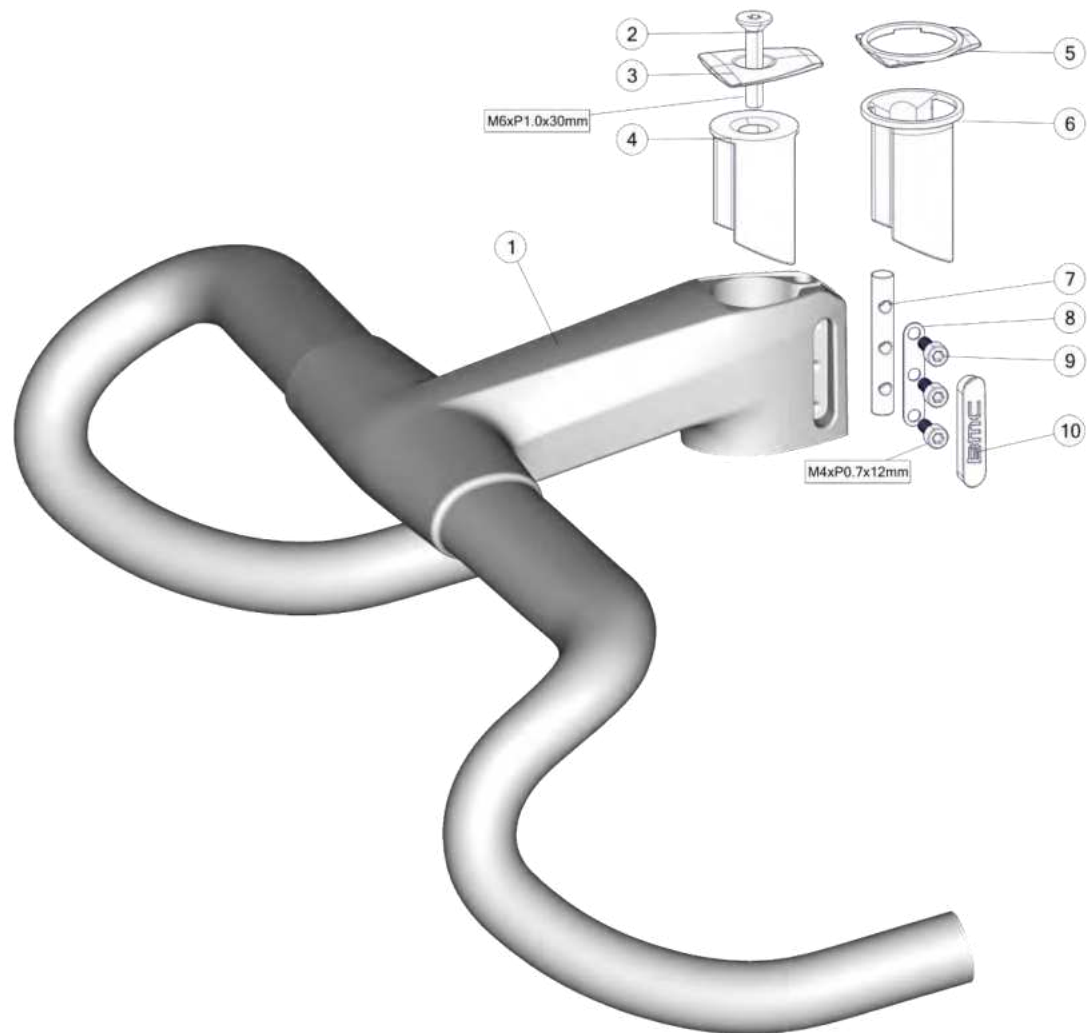

Pos. N°	Part N°	Part Name	Description	Angle	Drop	Reach
1-10	30001767	Cockpit ICS Carbon 90 400 BLACK - p2p	w/o spacers or top cones w/o computer mount	-12.5°	127	67
1-10	30001768	Cockpit ICS Carbon 100 420 BLACK - p2p		-12.5°	127	67
1-10	30001769	Cockpit ICS Carbon 110 420 BLACK - p2p		-12.5°	127	67
1-10	30001770	Cockpit ICS Carbon 120 420 BLACK - p2p		-12.5°	127	67
1-10	30001771	Cockpit ICS Carbon 110 400 BLACK TEAM - p2p		-12.5°	127	77
1-10	30001772	Cockpit ICS Carbon 120 400 BLACK TEAM - p2p		-12.5°	127	77
1-10	30001773	Cockpit ICS Carbon 130 400 BLACK TEAM - p2p		-12.5°	127	77
1-10	30001774	Cockpit ICS Carbon 140 400 BLACK TEAM - p2p		-12.5°	127	77
1-10	30001775	Cockpit ICS Carbon 90 400 RED - p2p		-12.5°	127	67
1-10	30001776	Cockpit ICS Carbon 100 420 RED - p2p		-12.5°	127	67
1-10	30001777	Cockpit ICS Carbon 110 420 RED - p2p		-12.5°	127	67
1-10	30001778	Cockpit ICS Carbon 120 420 RED - p2p		-12.5°	127	67
1-10	30001779	Cockpit ICS Carbon 110 400 RED TEAM - p2p		-12.5°	127	77
1-10	30001780	Cockpit ICS Carbon 120 400 RED TEAM - p2p		-12.5°	127	77
1-10	30001781	Cockpit ICS Carbon 130 400 RED TEAM - p2p		-12.5°	127	77
1-10	30001782	Cockpit ICS Carbon 140 400 RED TEAM - p2p		-12.5°	127	77
1-10	30003257	Cockpit ICS Carbon 90 400 WHITE - p2p		-12.5°	127	67
1-10	30003258	Cockpit ICS Carbon 100 420 WHITE - p2p		-12.5°	127	67
1-10	30003259	Cockpit ICS Carbon 110 420 WHITE - p2p		-12.5°	127	67
1-10	30003260	Cockpit ICS Carbon 120 420 WHITE - p2p		-12.5°	127	67
1-10	30003261	Cockpit ICS Carbon 110 400 WHITE TEAM - p2p		-12.5°	127	77
1-10	30003262	Cockpit ICS Carbon 120 400 WHITE TEAM - p2p		-12.5°	127	77
1-10	30003263	Cockpit ICS Carbon 130 400 WHITE TEAM - p2p		-12.5°	127	77
1-10	30003264	Cockpit ICS Carbon 140 400 WHITE TEAM - p2p		-12.5°	127	77

ICS CARBON PART KITS

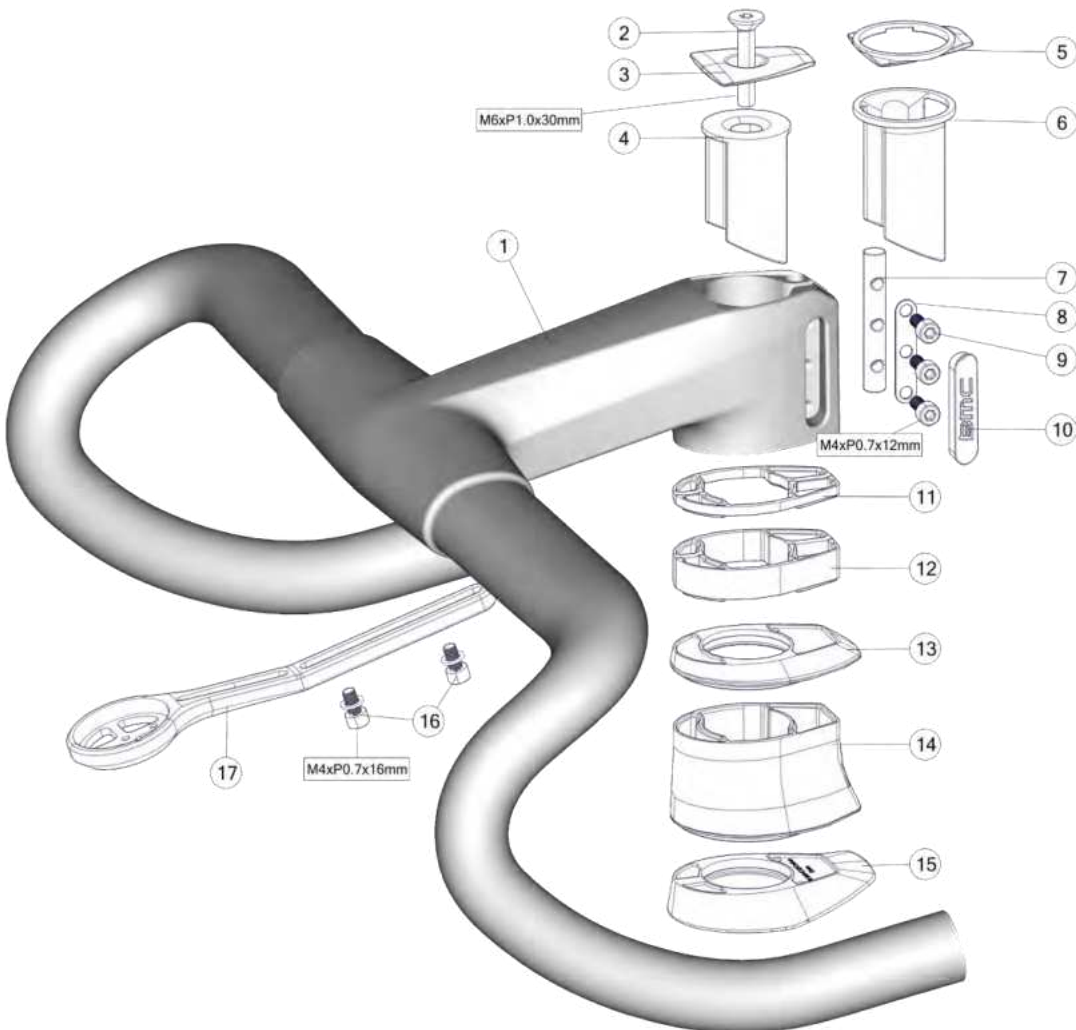

Pos. N°	Part N°	Part Name	Description
2 - 10	30000709	RED ICS Carbon Cockpit Hardware (Top Caps, steerer wedges, clamp insert, bolt cover, bolts)	including self cutting bolt
2 - 10	30001783	BLACK ICS Carbon Cockpit Hardware (Top Caps, steerer wedges, clamp insert, bolt cover, bolts)	including self cutting bolt
2 - 10	30003731	WHITE ICS2 Carbon Cockpit Hardware (Top Caps, steerer wedges, clamp insert, bolt cover, bolts)	including self cutting bolt
11 - 14	30001802	Topcone Set SLR01 RED ICS2, ICS Carbon (5mm & 30mm topcones, 3x10mm, 2x3mm spacers) - p2p	red top cones and spacers, for SLR01, KAS01, RM01 AMP, SLR AMP
11 - 14	30001801	Topcone Set SLR01 BLK ICS2, ICS Carbon, (5mm & 30mm topcones, 3x10mm, 2x3mm spacers) - p2p	black top cones and spacers, for SLR01, KAS01, RM01 AMP, SLR AMP
11 - 14	30003256	Topcone Set SLR01 WHITE ICS2, ICS Carbon (5mm & 30mm topcones, 3x10mm, 2x3mm spacers) - p2p	white top cones and spacers, for SLR01, KAS01, RM01 AMP, SLR AMP
11, 12, 15	30003734	Topcone Set TMR01 RED ICS2 (12mm topcone, 3x10mm, 2x3mm spacers) - p2p	red top cones and spacers, for TMR01
11, 12, 15	30003732	Topcone Set TMR01 BLK ICS2 (12mm topcone, 3x10mm, 2x3mm spacers) - p2p	black top cones and spacers, for TMR01
11, 12, 15	30003733	Topcone Set TMR01 WHT ICS2 (12mm topcone, 3x10mm, 2x3mm spacers) - p2p	white top cones and spacers, for TMR01
16, 17	30003196	Alloy Computer Mount for ICS Carbon cockpit with Wahoo and Garmin inserts, including GoPro mount	max load: 180g
6	30003340	ICS Carbon Cockpit Open Top Cap & Wedge	

ICS CARBON AERO COCKPIT

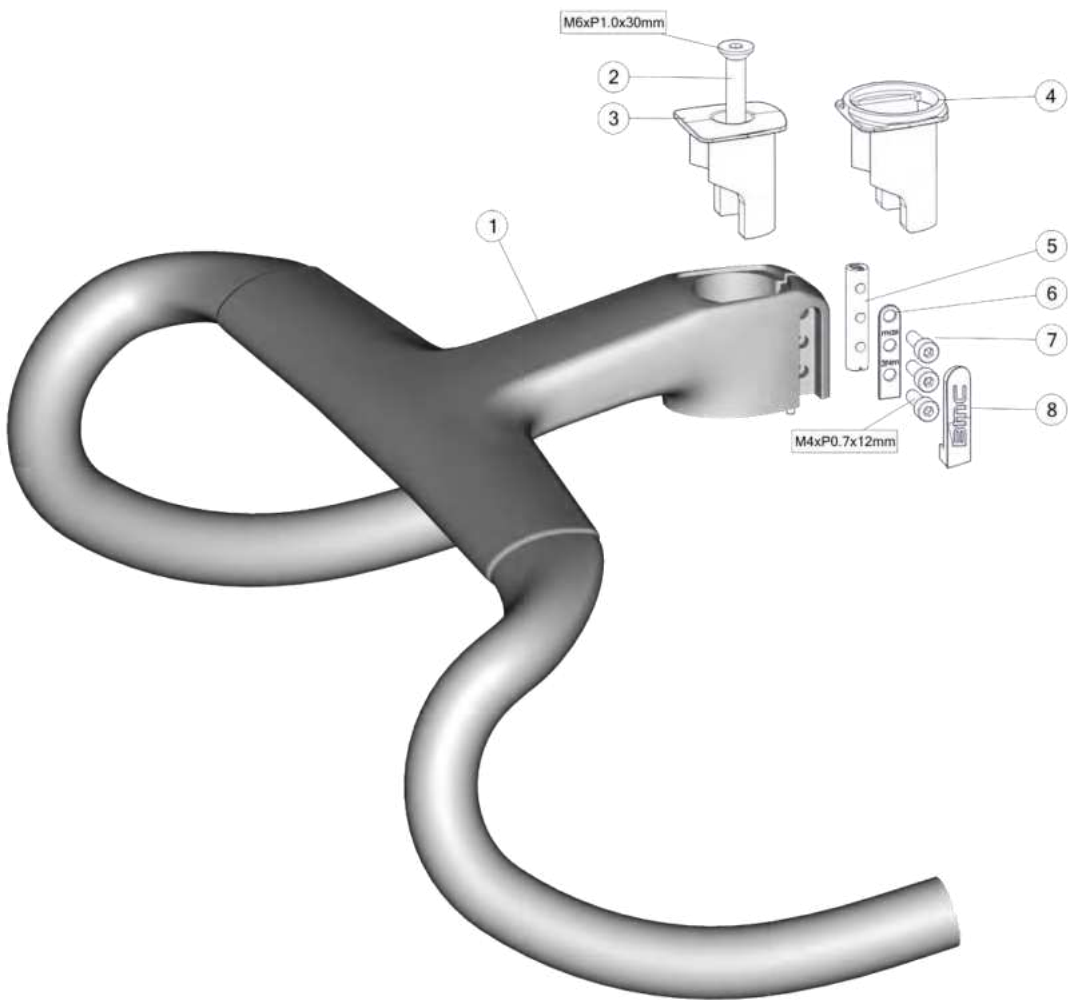

Pos. N°	Part N°	Part Name	Description	Angle	Drop	Reach
1-B	30003706	Cockpit ICS2 Carbon AERO 80 360/420 RED - p2p	w/o spacers or top cones w/o computer mount	-12.5°	135	72.5
1-B	30003707	Cockpit ICS2 Carbon AERO 90 360/420 RED - p2p		-12.5°	135	72.5
1-B	30003708	Cockpit ICS2 Carbon AERO 100 360/420 RED - p2p		-12.5°	135	72.5
1-B	30003709	Cockpit ICS2 Carbon AERO 110 360/420 RED - p2p		-12.5°	135	72.5
1-B	30003710	Cockpit ICS2 Carbon AERO 120 360/420 RED - p2p		-12.5°	135	72.5
1-B	30003711	Cockpit ICS2 Carbon AERO 130 360/420 RED - p2p		-12.5°	135	72.5
1-B	30003712	Cockpit ICS2 Carbon AERO 140 360/420 RED - p2p		-12.5°	135	72.5
1-B	30003713	Cockpit ICS2 Carbon AERO 80 360/420 WHITE - p2p		-12.5°	135	72.5
1-B	30003714	Cockpit ICS2 Carbon AERO 90 360/420 WHITE - p2p		-12.5°	135	72.5
1-B	30003715	Cockpit ICS2 Carbon AERO 100 360/420 WHITE - p2p		-12.5°	135	72.5
1-B	30003716	Cockpit ICS2 Carbon AERO 110 360/420 WHITE - p2p		-12.5°	135	72.5
1-B	30003717	Cockpit ICS2 Carbon AERO 120 360/420 WHITE - p2p		-12.5°	135	72.5
1-B	30003718	Cockpit ICS2 Carbon AERO 130 360/420 WHITE - p2p		-12.5°	135	72.5
1-B	30003719	Cockpit ICS2 Carbon AERO 140 360/420 WHITE - p2p		-12.5°	135	72.5
1-B	30003720	Cockpit ICS2 Carbon AERO 80 360/420 BLACK - p2p		-12.5°	135	72.5
1-B	30003721	Cockpit ICS2 Carbon AERO 90 360/420 BLACK - p2p		-12.5°	135	72.5
1-B	30003722	Cockpit ICS2 Carbon AERO 100 360/420 BLACK - p2p		-12.5°	135	72.5
1-B	30003723	Cockpit ICS2 Carbon AERO 110 360/420 BLACK - p2p		-12.5°	135	72.5
1-B	30003724	Cockpit ICS2 Carbon AERO 120 360/420 BLACK - p2p		-12.5°	135	72.5
1-B	30003725	Cockpit ICS2 Carbon AERO 130 360/420 BLACK - p2p		-12.5°	135	72.5
1-B	30003726	Cockpit ICS2 Carbon AERO 140 360/420 BLACK - p2p		-12.5°	135	72.5

ICS CARBON AERO PART KITS

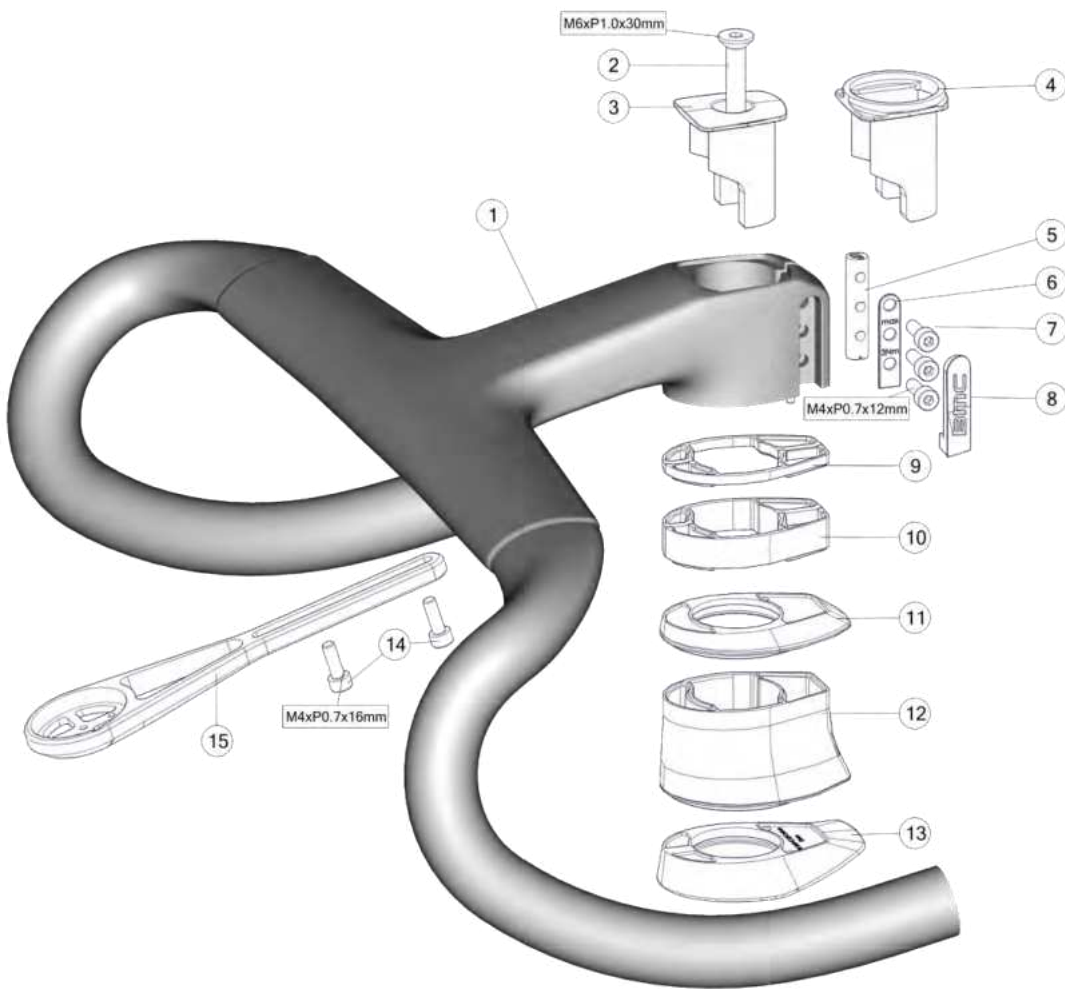

Pos. N°	Part N°	Part Name	Description
2-8	30003727	RED ICS2 AERO Cockpit Hardware (Top Caps, steerer wedges, clamp insert, bolt cover, bolts)	including self cutting bolt
2-8	30003728	WHITE ICS2 AERO Cockpit Hardware (Top Caps, steerer wedges, clamp insert, bolt cover, bolts)	including self cutting bolt
2-8	30003729	BLACK ICS2 AERO Cockpit Hardware (Top Caps, steerer wedges, clamp insert, bolt cover, bolts)	including self cutting bolt
14, 15	30003730	Alloy Computer Mount for ICS2 Carbon Aero cockpit with Wahoo and Garmin inserts, including GoPro mount (TBD)	
9-12	30001802	Topcone Set SLR01 RED ICS2, ICS Carbon (5mm & 30mm topcones, 3x10mm, 2x3mm spacers) - p2p	red top cones and spacers, for SLR01, KAS01, RM01 AMP, SLR AMP
9-12	30003256	Topcone Set SLR01 WHITE ICS2, ICS Carbon (5mm & 30mm topcones, 3x10mm, 2x3mm spacers) - p2p	black top cones and spacers, for SLR01, KAS01, RM01 AMP, SLR AMP
9-12	30001801	Topcone Set SLR01 BLK ICS2, ICS Carbon, (5mm & 30mm topcones, 3x10mm, 2x3mm spacers) - p2p	white top cones and spacers, for SLR01, KAS01, RM01 AMP, SLR AMP
9, 10, 13	30003734	Topcone Set TMR01 RED ICS2 (12mm topcone, 3x10mm, 2x3mm spacers) - p2p	red top cones and spacers, for TMR01
9, 10, 13	30003732	Topcone Set TMR01 BLK ICS2 (12mm topcone, 3x10mm, 2x3mm spacers) - p2p	black top cones and spacers, for TMR01
9, 10, 13	30003733	Topcone Set TMR01 WHT ICS2 (12mm topcone, 3x10mm, 2x3mm spacers) - p2p	white top cones and spacers, for TMR01

ICS2 STEM & HANDLEBAR

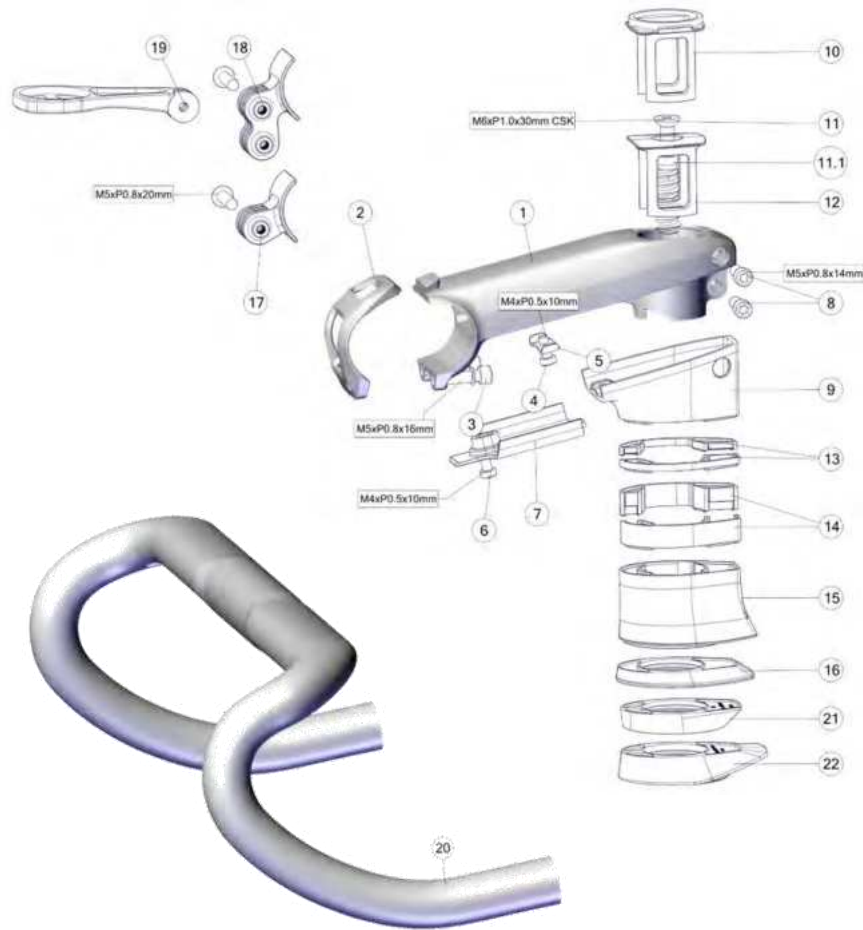

Pos. N°	Part N°	Part Name	Description	Angle		
1 - 9,11, 12, 17	30001784	STEM ICS2 - 80mm - p2p	w/o top cone or spacer including single mount	-12.5°		
	30001785	STEM ICS2 - 90mm - p2p		-12.5°		
	30001786	STEM ICS2 - 100mm - p2p		-12.5°		
	30001787	STEM ICS2 - 110mm - p2p		-12.5°		
	30001788	STEM ICS2 - 120mm - p2p		-12.5°		
	30001789	STEM ICS2 - 130mm - p2p		-12.5°		
	30001790	STEM ICS2 - 140mm - p2p		-12.5°		
10	30003341	ICS2 Topcap Interface Round				
2 - 12	30000708	ICS2 Hardware (face plate, cable clip, cable covers for all lengths, cable guide, top caps, bolts)	Cover for all stem length & self cutting bolt included			
13-16	30001800	Topcone Set SLR01 BLK ICS1, ICS AERO, ICS 0° (5mm & 30mm topcones, 3x10mm spacers) - p2p	ICS0° / ICS1 / ICS Aero stem → SLR01, KAS01, RM01 AMP, SLR AMP			
13-16	30001801	Topcone Set SLR01 BLK ICS2, ICS Carbon, (5mm & 30mm topcones, 3x10mm, 2x3mm spacers) - p2p	ICS2 stem → SLR01, KAS01, RM01 AMP, SLR AMP			
13-16	30001804	Topcone Set RM01 BLK ICS2, ICS Carbon (5mm & 30mm topcones, 3x10mm, 2x3mm spacers) - p2p	ICS2 stem → Teammachine SLR01/ SLR02 MY18-20; Roadmachine MY20-22; UnReSticted URS; Roadmachine AMP			
13, 14, 21	30002039	Topcone Set ICS2, round 257 AMP (3x10mm, 2x3mm spacers) - p2p	ICS2 (MTT) stem → 257 AMP/ 257/ AC AL/ URS AL/ RMX AL			
13, 14, 22	30003732	Topcone Set TMR01 BLK ICS2 (12mm topcone, 3x10mm, 2x3mm spacers) - p2p	ICS2 stem → TMR01			
17, 18, 19	30000718	Alloy Computer Mount for ICS2 and ICS01 Stems with Wahoo and Garmin inserts, including Single and Double Alloy brackets	Aluminium			
20	301707006919	Handlebar RCB01 400mm - p2p	400mm, stealth	117mm	77mm	Drop
20	301707006920	Handlebar RCB01 420mm - p2p	420mm, stealth, ca. 193g	117mm	77mm	Reach
20	301707006921	Handlebar RCB01 440mm - p2p	440mm, stealth	117mm	77mm	

Roadmachine MY17-19 are not compatible with ICS2 top cones and stem

ICS2 stem cannot be used in combination with round steerer forks (SLR, Roadmachine, SLR02, Roadmachine 02)

ICS MTT Suspension Stem

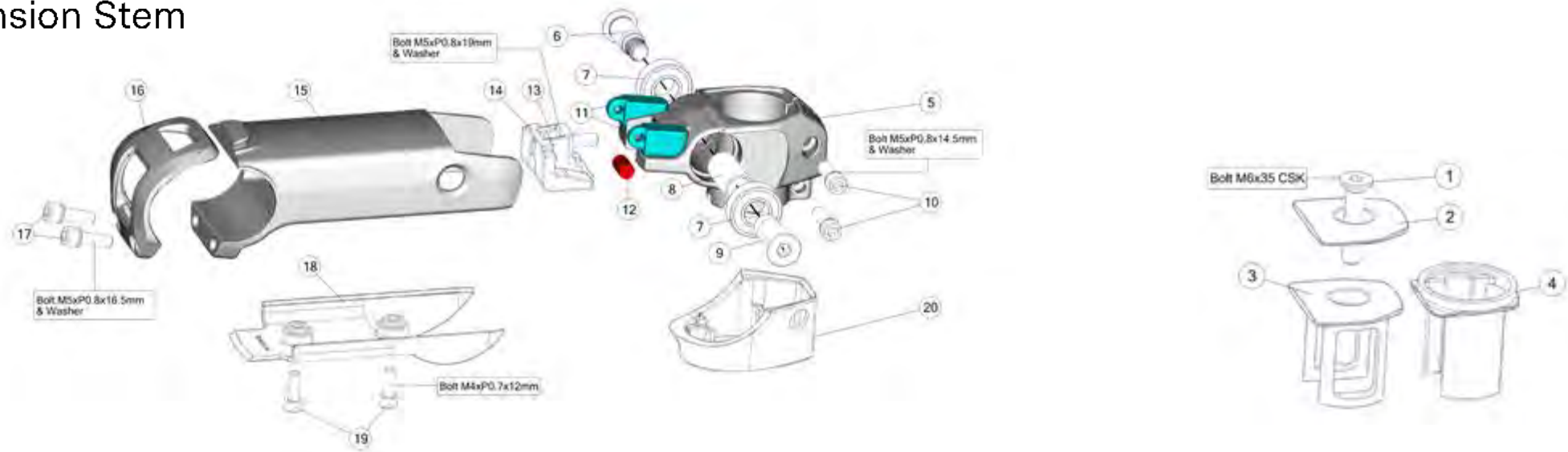

Pos. N°	Part N°	Description	Notes
1-20	30002032	Stem ICS2 MTT 70mm	
1-20	30002033	Stem ICS2 MTT 80mm	
1-20	30002034	Stem ICS2 MTT 90mm	
1-20	30002035	Stem ICS2 MTT 100mm	
1-20	30002036	Stem ICS2 MTT 110mm	
1-4/16-19	30002037	ICS2 MTT Cover Kit (Cable guide, cable covers, top caps, faceplate)	including bolts
11-14	30002038	ICS2 MTT Hardware (Elastomer bumpers)	including bumpers in different density
	30001801	Topcone Set SLR01 BLK ICS2, ICS Carbon, (5mm & 30mm topcones, 3x10mm, 2x3mm spacers) - p2p	ICS2 (MTT) stem → SLR01, KAS01, RM01 AMP, SLR AMP
	30001804	Topcone Set RM01 BLK ICS2, ICS Carbon (5mm & 30mm topcones, 3x10mm, 2x3mm spacers) - p2p	ICS2 (MTT) stem → Teammachine SLR01/ SLR02 MY18-20; Roadmachine MY20-22; UnReStricted URS; Roadmachine AMP
	30002039	Topcone Set ICS2, round 257 AMP (3x10mm, 2x3mm spacers) - p2p	ICS2 (MTT) stem → 257 AMP/ 257/ AC AL/ URS AL/ RMX AL

ICS1 & ICS0° STEM

ICS1 cable guide options

#5 for flat steerer #5 302221 for round steerer

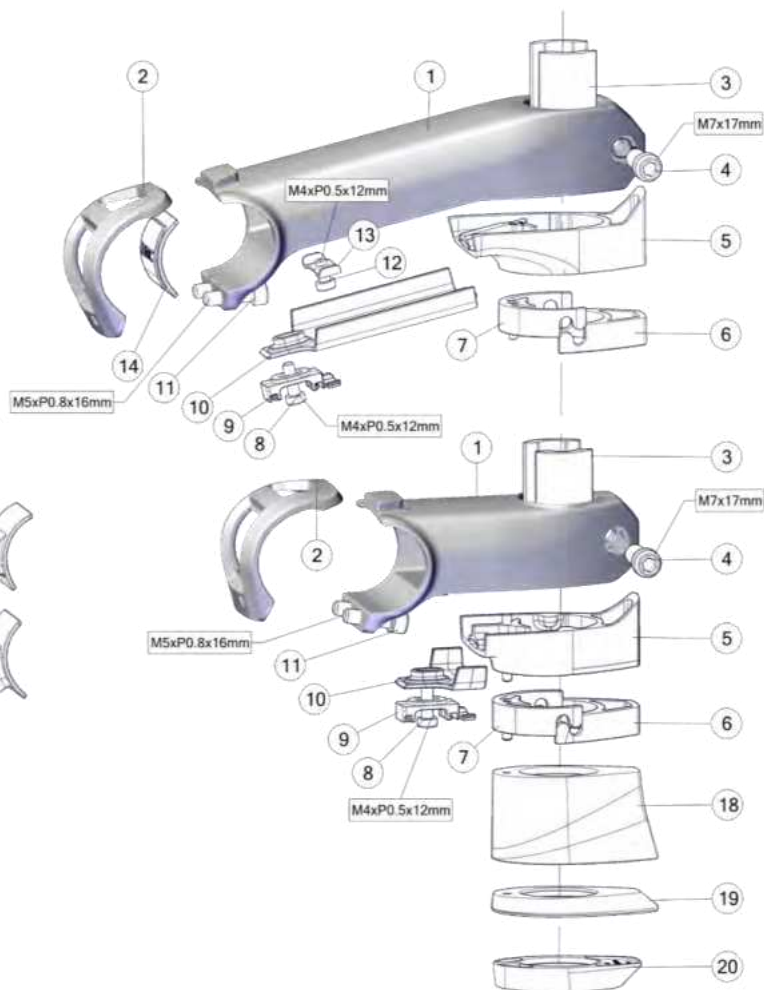
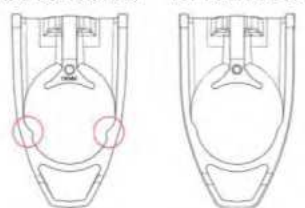

Pos. N°	Part N°	Part Name	Description	Angle
1 - 14	300881	Stem ICS01, 90mm	Sandblasted / black anodized	-12.5°
1 - 14	300882	Stem ICS01, 100mm	Sandblasted / black anodized	-12.5°
1 - 14	300883	Stem ICS01, 110mm	Sandblasted / black anodized	-12.5°
1 - 14	300884	Stem ICS01, 120mm	Sandblasted / black anodized	-12.5°
1 - 14	300885	Stem ICS01, 130mm	Sandblasted / black anodized	-12.5°
5	302221	Stem ICS01 Lower Stem Cover – Round Steerer*	To fit stem to round steerer forks	
5-7	301281	ICS01 stem PA spacer kit	Polyamid, 3 pair of spacers	
3 - 13	301651	ICS01 stem part kit	Including all covers (#10)	
14	300996	ICS01 stem faceplace cover		
1 - 5, 8 - 11, 15	3000179 5	Stem ICS 0°, 55mm - p2p	w/o top cone or spacer including single mount	0°
1 - 5, 8 - 11, 15	3000179 6	Stem ICS 0°, 70mm - p2p		0°
1 - 5, 8 - 11, 15	3000179 7	Stem ICS 0°, 80mm - p2p		0°
1 - 5, 8 - 11, 15	3000179 8	Stem ICS 0°, 90mm - p2p		0°
1 - 5, 8 - 11, 15	3000179 9	Stem ICS 0°, 100mm - p2p		0°
3-5, 8-10	302100	Stem ICS0° part kit	Including all covers (#10)	
15,16,17	3000071 8	Alloy Computer Mount for ICS2 and ICS01 Stems with Wahoo and Garmin inserts, including Single and Double Alloy brackets	Aluminium	
6, 7, 18, 19	3000180 3	Topcone Set RM01 BLK ICS1, ICS AERO, ICS 0°(5mm & 30mm topcones, 3x10mm spacers) - p2p	ICS1/ ICS Aero/ ICS 0° stem → Teammachine SLR01/ SLR02 MY18-20; Roadmachine MY20-22; UnReStRicted URS; Roadmachine AMP	
6, 7, 18, 19	3000180 0	Topcone Set SLR01 BLK ICS1, ICS AERO, ICS 0° (5mm & 30mm topcones, 3x10mm spacers) - p2p	ICS1/ ICS Aero/ ICS 0° stem→ SLR01, KAS01, RM01 AMP, SLR AMP	
6, 7, 20	300043 13	Topcone Set ICS1, round 257 (3x10mm spacers) - p2p	ICS1/ ICS Aero/ ICS 0° stem → 257 AMP/ 257/ AC AL/ URS AL/ RMX AL	

*Attention: #302221 does not fit with ICS0° stem!

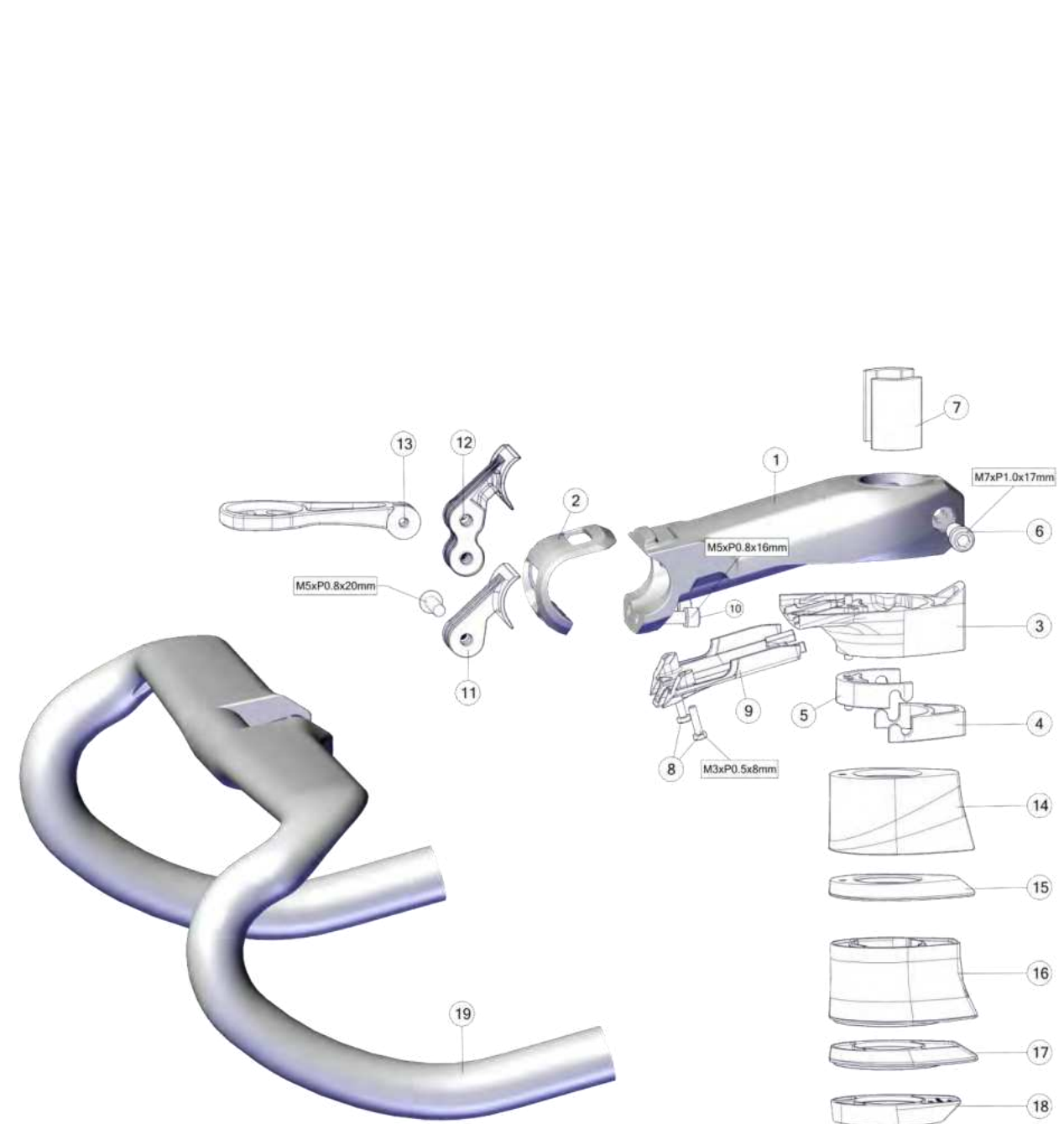

Pos. N°	Part N°	Part Name	Description	Angle	Drop	Reach
1 - 10	301704006915	Stem ICS01 AERO Stealth 100mm	100mm	-15°		
1 - 10	301704006916	Stem ICS01 AERO Stealth 110mm	110mm			
1 - 10	301704006917	Stem ICS01 AERO Stealth 120mm	120mm			
1 - 10	301704006918	Stem ICS01 AERO Stealth 130mm	130mm			
1 - 3, 6 - 11	30001791	STEM ICS Aero 100mm - p2p	w/o top cone or spacer including single mount			
1 - 3, 6 - 11	30001792	STEM ICS Aero 110mm - p2p				
1 - 3, 6 - 11	30001793	STEM ICS Aero 120mm - p2p				
1 - 3, 6 - 11	30001794	STEM ICS Aero 130mm - p2p				
2 - 10	301666	ICS Aero stem part kit				
4, 5, 14, 15	30001803	Topcone Set RM01 BLK ICS1, ICS AERO, ICS 0°(5mm & 30mm topcones, 3x10mm spacers) - p2p	ICS1/ ICS Aero/ ICS 0° stem → Teammachine SLR01/ SLR02 MY18-20; Roadmachine MY20-22; UnReStRicted URS; Roadmachine AMP			
4, 5, 16, 17	30001800	Topcone Set SLR01 BLK ICS1, ICS AERO, ICS 0° (5mm & 30mm topcones, 3x10mm spacers) - p2p	ICS1/ ICS Aero/ ICS 0° stem→ SLR01, KAS01, RM01 AMP, SLR AMP			
4, 5, 18	30004313	Topcone Set ICS1, round 257 (3x10mm spacers) - p2p	ICS1/ ICS Aero/ ICS 0° stem → 257 AMP/ 257/ AC AL/ URS AL/ RMX AL			
11, 13	301703	Garmin/Go-Pro ICS01 AERO Stem mount set	Polyamid Not suited for devices over 100g!			
11,12,13	30000719	Alloy Computer Mount for ICS Aero Stems with Wahoo and Garmin inserts, including Single and Double Alloy brackets	Aluminium			
19	302068008091	Handlebar ICS AERO 400mm - p2p	400mm, stealth		122mm	64mm
19	302068008092	Handlebar ICS AERO 420mm - p2p	420mm, stealth, ca. 232g		122mm	64mm
19	302068008093	Handlebar ICS AERO 440mm - p2p	440mm, stealth		122mm	64mm
19	302081008105	Handlebar ICS AERO TEAM Stealth 400mm	400mm, stealth		126mm	80mm
19	302081008106	Handlebar ICS AERO TEAM Stealth 420mm	420mm, stealth		126mm	80mm
19	302081008107	Handlebar ICS AERO TEAM Stealth 440mm	440mm, stealth		126mm	80mm
	30000749	ICS Aero Clip-On Extensions				

BMC

