



# Mounting and Maintenance

OSPW RS for Shimano Dura Ace 9250 + Ultegra 8150  
and 105 7150

*CERAMICSPEED*

# Maintenance

No set of rules can be made for how often your Oversized Pulley Wheels are to be maintained. Maintenance frequency depends on the weather conditions that you are riding in.

A worn chain will increase the wear on the pulley wheels significantly, so make sure that you change your chain before it is completely worn out.

We recommend the use of CeramicSpeed Oil on the OSPW RS system. This can be purchased from the CeramicSpeed dealers worldwide or from our webshop. Watch our maintenance video on [ceramicspeed.com](http://ceramicspeed.com) in the Support section.

For the ALPHA Disc pulley with ADR, maintenance of the bearings should occur at least one to two times per year, every 10.000 km/6.000 miles in normal conditions, or every 5.000 km/3.000 miles in extreme or harsh conditions. Remove the back side cage plate & both pulleys to clean all components thoroughly. With the ADR shields removed, carefully remove the bearing seals and flush the bearings following the UFO Bearing Cleaner instructions. Apply a few drops of UFO Pulley Oil and reinstall the pulley seals. Take careful note of the rotation direction of the pulleys with ADR when reinstalling into the cage. The cage tower bolts are torqued to 1,5Nm

For the 5-Spoke alloy pulleys, maintenance of the bearings should occur at least two to three times per year, every 5.000 km/3.000 miles in normal conditions, or every 3.000 km/1.800 miles in extreme or harsh conditions. Remove the back side cage plate & both pulleys to clean all components thoroughly. Carefully remove the bearing seals and flush the bearings following the UFO Bearing Cleaner instructions. Apply a few drops of UFO Pulley Oil and reinstall the pulley seals. Take careful note of the rotation direction of the pulleys when reinstalling into the cage. The cage tower bolts are torqued to 1,5Nm.

# Tools required

For the installation of your new CeramicSpeed OSPW RS for Shimano Dura Ace 9250 + Ultegra 8150, and 105 7150, you will need the following tools:

A: Chain Tool

B: T10 Torx® Screwdriver

C: Philips screwdriver no. 2

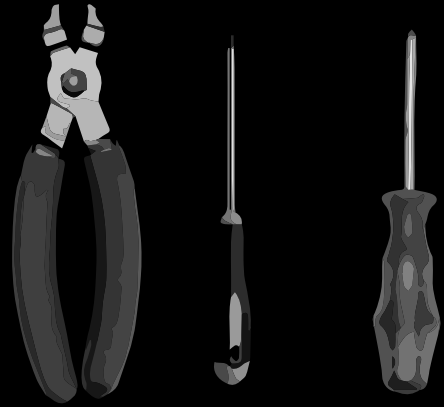

A

B

C

## Mounting the CeramicSpeed Oversized Pulley Wheel System RS for Shimano DA 9200

Pos.	Description
1	Cage bolts
2	13T Upper ALPHA Disc
3	Stainless steel ADR Dust Shield
4	Front cage plate
5	19T Lower ALPHA Disc
6	Back cage plate
7	Derailleur body gasket

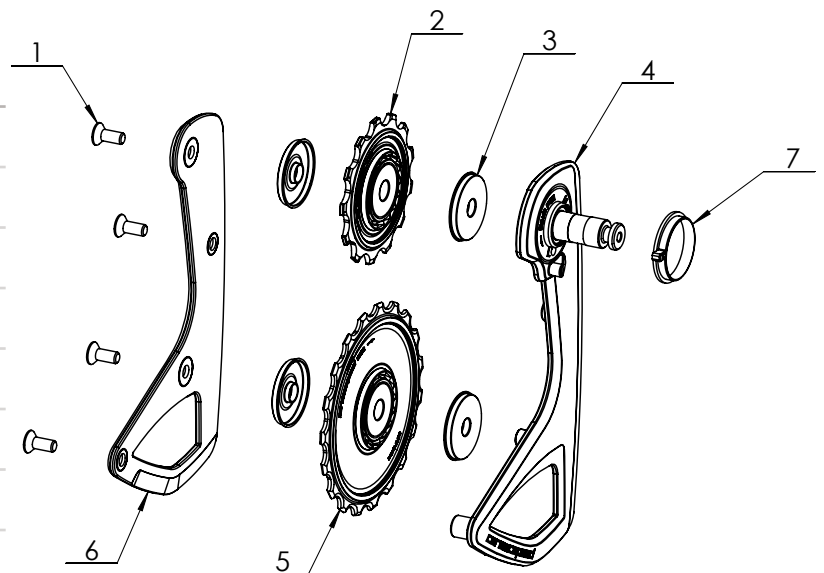

**NOTE:**

- 5-Spoke alloy pulleys have stainless steel bushing to fit pulley posts.
- Shimano 105 7150 and Ultegra 8150 use the factory derailleur body spacer.

# Mounting Manual

To ensure the very best in riding performance it is vital that your new OSPW RS System is mounted correctly. Follow these instructions to install your OSPW RS System for Shimano Dura Ace 9250 + Ultegra 8150, or 105 7150.

Note: the 105 7150 system follows the same instructions as the Ultegra 8150, however the cages and derailleurs are not interchangeable with each other.



Begin with your bike mounted in a stand and remove the rear wheel.



Upon completion of installing the OSPW RS System you will need to use a new, longer chain.

Remove the chain with a proper chain tool. Upon completion of installing the OSPW RS System you will need to use a new, longer chain.

Note: it is not recommended to add links to a previously ridden chain.

**3**

Locate the black mounting screw on the bottom of the derailleur body. Use a T10 Torx screwdriver to remove the black T10 mounting screw. Only half of the screw is threaded. Once the screw is about 1 cm out and the threads are not engaged, slide the screw the rest of the way out with your hand. Secure the cage in the derailleur body with your thumb.

**4**

Shift the derailleur up so the cage will be able to rotate and not hit the derailleur body. For Ultegra 8150 or 105 7150, remove the rotation stop screw using a Philips screwdriver, and carefully allow the cage to unwind. For Dura Ace 9250, pull the cage by hand away from the derailleur body until the stop tower is free and carefully allow the pulley cage spring to unwind, releasing the spring tension. Your derailleur cage will appear to be upside down.

**5**

Slide out the original pulley cage and spring assembly, careful not to drop the pulley spring and plastic spacer.



**6**

Remove the spring and plastic spacer from the Shimano cage. The end of the spring is hooked to lock into the pulley cage. Keep these aside as you will reuse these for the installation of the OSPW RS System on Ultegra 8150 or 105 7150. You do not need the plastic spacer for the Dura Ace 9250 as you will use the thicker spacer supplied with the OSPW RS System.

**7**

Unpack the OSPW RS System.

For Ultegra or 105, place the original spring and plastic spacer over the mounting post of the OSPW RS System in the same manner they were removed from the stock cage. The hooked end goes toward the OSPW RS cage as well as the flat edge of the plastic spacer. For Dura Ace, you will use the thicker spacer supplied with the OSPW RS System.

**8**

Note the four spring tension settings on the OSPW RS cage: from H (high) to L (low). The L tension setting will reduce both chain tension and friction, but will also result in slightly compromised shifting performance. The H tension setting will deliver the highest frictions levels but deliver the strongest chain retention for rougher roads or mixed surfaces.

**9**

Select the spring tension hole second from 'L' (second lowest tension) and insert the hooked end of the spring completely. This may need to be pressed firmly. The plastic spacer will rest freely on the spring until aligned at the back of the derailleur body.

**10**

Rotate the derailleur body back, align the mounting post of the OSPW RS System to the back of the derailleur body with the cage pointing to the front of the bike. Align the tension spring and plastic spacer with the slot on the derailleur body and insert until the cage is flush to the derailleur. Ensure the OSPW RS cage rotates smoothly and the spring is properly secured.

**11**

Hold the OSPW RS cage against the derailleur body and rotate counter-clockwise (first up and then to the back of the bike and downward) until you feel the ramped stop tower click past the stop point on the derailleur.

12



Secure the cage by reinstalling the original black T10 screw (removed at step 3). Installation torque is 1Nm. Your new OSPW RS System is now installed.

13



Shift the derailleur down to the bottom and install the rear wheel. Install a new chain according to the guide on the following page. Ensure the derailleur hanger is accurately aligned, check the upper and lower stops of the derailleur, and set the b-limit gap between 4-7mm at the largest cog and upper pulley. Adjust the Di2 trim for proper alignment between the cogs and pulley wheels. If in doubt, have a qualified mechanic make the final gear adjustments.

Note: For the best result use an original Shimano 12spd Cassette (11-36T Max).



# Chain length

Test the present chain length acc. to the description below.

If it turns out to be necessary to change the chain length, follow the description below.

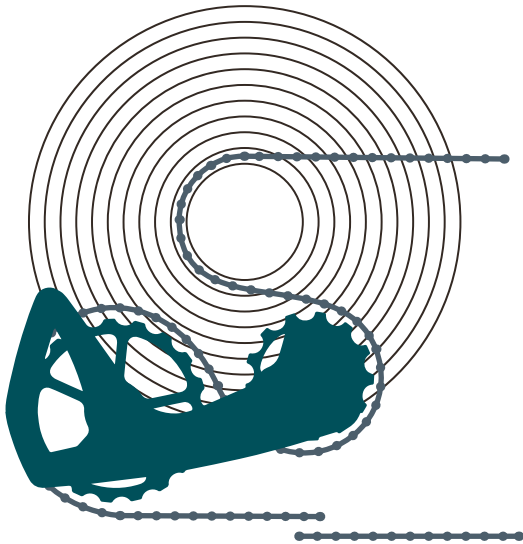

**STEP 1:** Place the chain on the smallest cog on the cassette and the small front chain ring. To find the correct chain length, pull the two chain ends together, just as you would when needing to cut a chain to length. The lower part of the cage should start to move downwards, away from the cassette, as referenced in the second image.

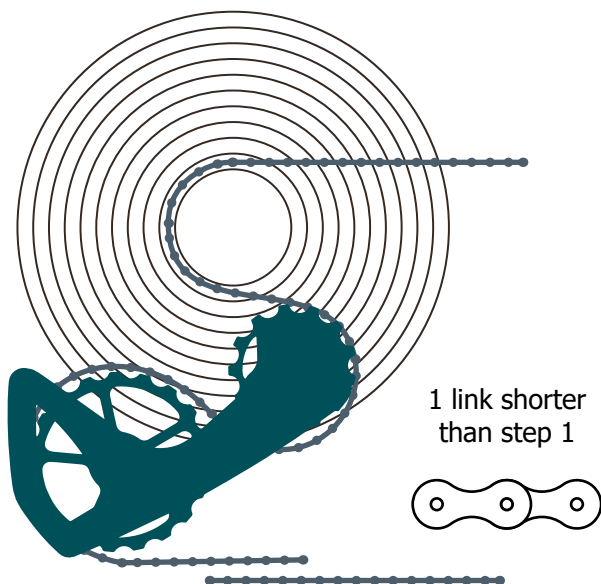

**STEP 2:** When tension is applied on the chain and the OSPW RS System appears to be aligned as the diagram on the left, the chain needs to be cut (1 link shorter than step 1) and connected by the required amount of links in order to achieve sufficient tension in this gear combination (always the small cog on the cassette).

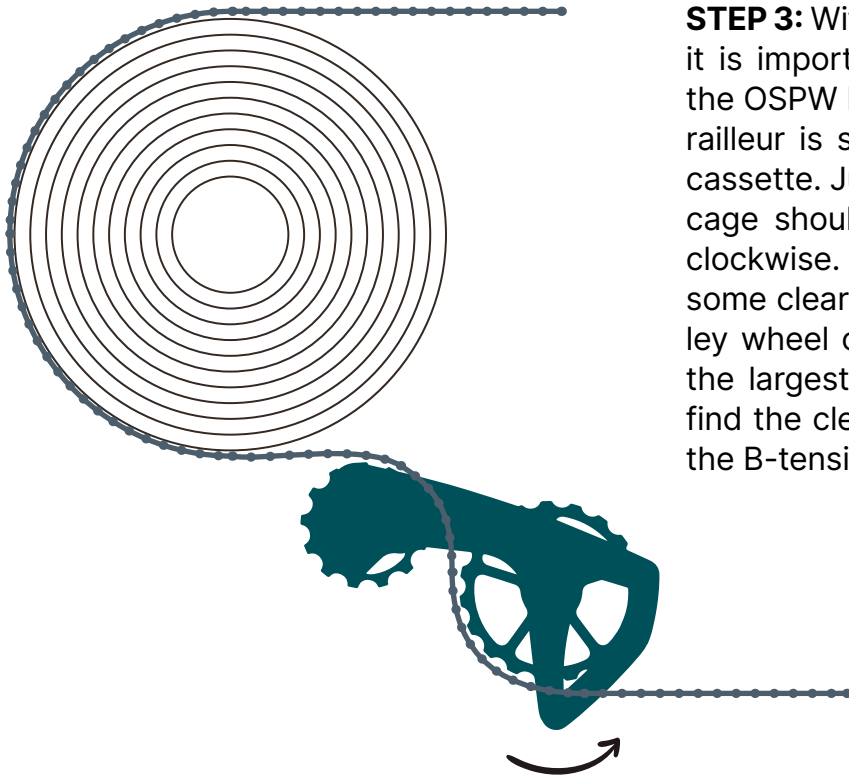

**STEP 3:** With the chain now cut to length it is important to test the clearance of the OSPW RS System when the rear derailleur is set in the largest cog on the cassette. Just as the arrow indicates the cage should be able to rotate counter clockwise. It is important that there is some clearance between the upper pulley wheel of the OSPW RS System and the largest cog on the cassette. If you find the clearance is not enough, adjust the B-tension accordingly.

**CERAMICSPEED**

# Up to a Lifetime warranty

Thankfully, we do not have to deal with warranty issues often. Nevertheless, we are happy to introduce you to our comprehensive warranty program.

## Standard products 4 years

Bottom Brackets

Pulley Wheels

Wheel Kits

Headsets

Oversized Pulley Wheel Systems

Single Bearings

## Lifetime warranty products

Coated Bottom Brackets

Coated Pulley Wheels

Coated Wheel Kits

Coated Headsets

Coated Single bearings

SLT OHD Headsets

SLT OPD Pivot bearings

Coated OSPW Systems

ALPHA Disc OSPW Systems

All OSPW Cages

We are committed to manufacturing and delivering the best ceramic bearing products in the industry. Should your CeramicSpeed product not live up to your expectations, and this is caused by defects in materials and/or workmanship, we encourage you to contact us.

Register your product within the first 30 days of purchase by clicking [here](#) or go to [ceramicspeed.com/cycling](https://ceramicspeed.com/cycling) under the section Support. Should you thereafter, and within the warranty period need to file a claim, please return to the same section on our website and fill in your claim. We will always strive to revert to you concerning your claim within 24 hours.